

430/440MHz FM TRANSCEIVER

IC-04A/AT/E

SERVICE MANUAL



ICOM INCORPORATED

6-9-16, Kamihigashi, Hirano-ku, Osaka 547, Japan

Phone : 06 793 5301

Fax : 06 793 0013

Telex : 0527722 ICOMTR J

ICOM AMERICA Inc.

<Corporate Headquarters>
2380 116th Avenue N.E.,
Bellevue WA 98004, U.S.A.

Phone : 206 454 8155

Fax : 206 454 1509

Telex : 152210 ICOM AMER BVUE

<Customer Service>

Phone : 206 454 7819

<Regional Customer Service Center>
3150 Premier Drive, Suite 126, Irving,
TX 75063, U.S.A.

Phone : 214 550 7525

Fax : 214 594 7079

1777 Phoenix Parkway, Suite 201,
Atlanta, GA 30349, U.S.A.

Phone : 404 991 8186

Fax : 404 991 6327

ICOM CANADA

A Division of ICOM America Inc.
3071 #5 Road, Unit 9, Richmond, B.C.,
V6X 2T4, Canada

Phone : 604 273 7400

Fax : 604 273 1900

ICOM (EUROPE) GmbH

Himmelgeister Str. 100,
4000 Düsseldorf 1,
Fed. Rep. Germany

Fon : 0211 348047

Fex : 0211 333639

Telex : 8588082 ICOM D

ICOM (AUSTRALIA) Pty. Ltd.

7 Duke Street, Windsor, Victoria,
3181 Australia

Phone : 03 51 2284, 03 529 7582

Fax : 03 529 8485

Telex : AA 35521 ICOM AS

ICOM (UK) Ltd.

Unit 9, Sea Street, Herne Bay,
Kent CT6 8LD, United Kingdom

Phone : 0227 363859

Fax : 0227 360155

Telex : 965179 ICOM G

ICOM FRANCE S.a

120 Route de Revel,
31029 Toulouse Cedex, France

Phone : 61. 20. 31. 49

Fax : 61. 34. 05. 91

Telex : 521515 ICOM FRA

INTRODUCTION

This service manual contains information relative to the theoretical, physical, mechanical and electrical characteristics of the IC-04A/AT/E 430/440MHz FM TRANSCEIVER.

ASSISTANCE

Four separate versions of the IC-04A /AT /E have been designed for use in the Europe, U.S.A., Australia, and Southeast Asia. This service manual covers every version. When using the manual each model can be referred to by the following assigned version numbers:

MODEL	VERSION NO.	VERSION	FREQUENCY RANGE (MHz)	TONE ENCODERS	TUNING STEP (kHz)
IC-04E	#04	Europe (3)	430.000~439.9875	TONE CALL	12.5
IC-04AT	#05	U.S.A. (1)	440.000~449.995	DTMF CTCSS	5
IC-04A	#07	Australia	430.000~439.995	---	5
IC-04AT	#09	Southeast Asia (2)	430.000~439.995	DTMF CTCSS	5

If you require assistance or further information regarding the operation and capabilities of the IC-04A/AT/E please contact your nearest authorized ICOM Dealer or ICOM Service Center.

ORDERING PARTS

For faster, more efficient service include the following points when ordering parts or requesting information from your ICOM Service Center:

1. Equipment model and serial number
2. Schematic part identifier (e.g., Q205)
3. Printed circuit board name and number (e.g., PLL UNIT/B-816I)
4. Part number and name (e.g., 2SC2668-O Transistor)
5. Quantity required (e.g., 3pcs)

REPAIR NOTE

1. DO NOT open transceiver covers until the transceiver is disconnected from a power source.
2. DO NOT connect the transceiver to an external power source of more than 16V DC.
3. DO NOT force any of the variable components. Turn them slowly and smoothly.
4. DO NOT short any circuits or electronic components.
5. An insulated tuning tool MUST BE used for all adjustments.
6. DO NOT keep power ON for a long time when the transceiver is defective.
7. DO NOT transmit power into a signal generator or sweep generator. Always connect a 30dB or 40dB attenuator between the transceiver and a deviation meter or spectrum analyzer when using such test equipment.
8. Read the instructions of test equipment thoroughly before connecting the equipment to the transceiver.



TABLE OF CONTENTS

SECTION	1	SPECIFICATIONS	1-1
SECTION	2	OUTSIDE AND INSIDE VIEWS	2-1~2
	2-1	OUTSIDE VIEWS	2-1
	2-2	INSIDE VIEWS	2-2
SECTION	3	BLOCK DIAGRAM	3-1
SECTION	4	CIRCUIT DESCRIPTION	4-1~9
	4-1	RECEIVER CIRCUIT	4-1
	4-2	TRANSMITTER CIRCUIT	4-2
	4-3	PLL CIRCUIT	4-3
	4-4	POWER SUPPLY CIRCUIT	4-5
	4-5	COMPARATOR, REDUCED VOLTAGE DETECTION CIRCUITS	4-5
	4-6	LOGIC CIRCUIT	4-6
	4-7	OTHER CIRCUITS	4-6
SECTION	5	MECHANICAL PARTS AND DISASSEMBLY	5-1~4
	5-1	REAR PANEL DISASSEMBLY	5-1
	5-2	FRAME DISASSEMBLY	5-1
	5-3	SOLDER SIDE DISASSEMBLY	5-2
	5-4	TOP PANEL DISASSEMBLY	5-3
	5-5	HEATSINK DISASSEMBLY	5-3
	5-6	SPEAKEY/MICROPHONE DISASSEMBLY	5-4
	5-7	BOTTOM UNIT DISASSEMBLY	5-4
	5-8	PTT PLATE AND PTT SEAL DISASSEMBLY	5-4
	5-9	LOGIC UNIT AND LCD DISASSEMBLY	5-4
SECTION	6	MANTENANCE AND ADJUSTMENT	6-1~5
	6-1	MEASURING INSTRUMENTS REQUIRED FOR ADJUSTMENTS	6-1
	6-2	CHECK THE FUNDAMENTAL VOLTAGES	6-2
	6-3	PLL ADJUSTMENT	6-3
	6-4	RECEIVER ADJUSTMENT	6-3
	6-5	TRANSMITTER ADJUSTMENT	6-4
	6-6	SUBAUDIBLE TONE, DTMF AND TONE CALL ADJUSTMENT	6-5
SECTION	7	BOARD LAYOUT	7-1~4
	7-1	MAIN UNIT	7-1
	7-2	PLL UNIT AND VCO UNIT	7-2
	7-3	LOGIC UNIT	7-3
	7-4	TONE UNIT	7-4
	7-5	TONE CALL UNIT	7-4
SECTION	8	SCHEMATIC DIAGRAM	8-1~4
	8-1	MAIN UNIT	8-1
	8-2	PLL UNIT	8-2
	8-3	LOGIC UNIT	8-3
	8-4	TONE UNIT	8-4
	8-5	TONE CALL UNIT	8-4
SECTION	9	TROUBLE SHOOTING	9-1~4
	9-1	NO POWER	9-1
	9-2	PLL FAILURE	9-2
	9-3	NO RECEPTION	9-3
	9-4	NO TRANSMIT RF POWER	9-4
SECTION	10	PARTS LIST	10-1~8
SECTION	11	IC, TRANSISTOR AND PIN CONNECTIONS.	11-1~3

The SCHEMATIC DIAGRAM is attached at the end of this manual

SECTION 1 SPECIFICATIONS

■ GENERAL

MODEL	VERSION NO.	VERSION	FREQUENCY RANGE (MHz)	TUNING STEP (kHz)
IC-04E	#04	Europe (3)	430.000~439.9875	12.5
IC-04AT	#05	U.S.A. (1)	440.000~449.995	5
IC-04A	#07	Australia	430.000~439.995	5
IC-04AT	#09	Southeast Asia (2)	430.000~439.995	5

Frequency coverage and tuning steps :

Frequency readout : 6 digit 5kHz LCD READOUT

Frequency control : Digital PLL synthesizer with key input

Frequency stability : Within 0.001% in range of $-10^{\circ}\text{C} \sim +60^{\circ}\text{C}$

Memory channels : 10

Scanning : Programmed scan and memory channel scan available

Usable temperature range : $-10^{\circ}\text{C} \sim +60^{\circ}\text{C}$

Antenna impedance : 50Ω unbalanced

Power supply requirement : DC 5.5~16.0V negative ground is acceptable
([DC IN] JACK accepts 10~16V)

Current drain at 8.4V :

Transmit	HIGH (2.5W)	Approx.	1.25A
	LOW (0.5W)	Approx.	550mA
Receive	At max audio output	Approx.	150mA
	Squelched	Approx.	45mA

Dimensions(with IC-BP3) : 65(74)W x 160(171)H x 35(41)D mm
(Bracketed values include prejections)

Weight : 515g(IC-04AT/E) 495g(IC-04A)

■ TRANSMITTER

Output power : HIGH 2.5W at 8.4V (5W at 13.2V)
LOW 0.5W at 8.4V~13.2V

Emission mode : F3

Modulation system : Variable reactance frequency modulation

Max. frequency deviation : $\pm 5\text{kHz}$

Spurious emissions : More than 60dB below carrier output power

Microphone : Built-in electret condenser microphone
Optional Speaker-microphone (IC-HM9) and Headset (HS-10) can be used.

Operating mode : Simplex
Duplex (Any in-band frequency separation is programmable.)

■ RECEIVER

Receiving system : Double-conversion superheterodyne

Intermediate frequencies : 1st 21.8MHz, 2nd 455kHz

Sensitivity : Less than $0.3\mu\text{V}$ for 12dB SINAD
Less than $0.4\mu\text{V}$ for 20dB noise quieting

Squelch sensitivity : Less than $0.1\mu\text{V}$

Spurious response rejection ratio : More than 60dB

Selectivity : More than $\pm 7.5\text{kHz}$ at -6dB point
Less than $\pm 15\text{kHz}$ at -60dB point

Audio output power : More than 500mW (at 8Ω with 10% distortion)

Audio output impedance : 8Ω

SECTION 2 OUTSIDE AND INSIDE VIEW

2-1 OUTSIDE VIEWS

TOP VIEW

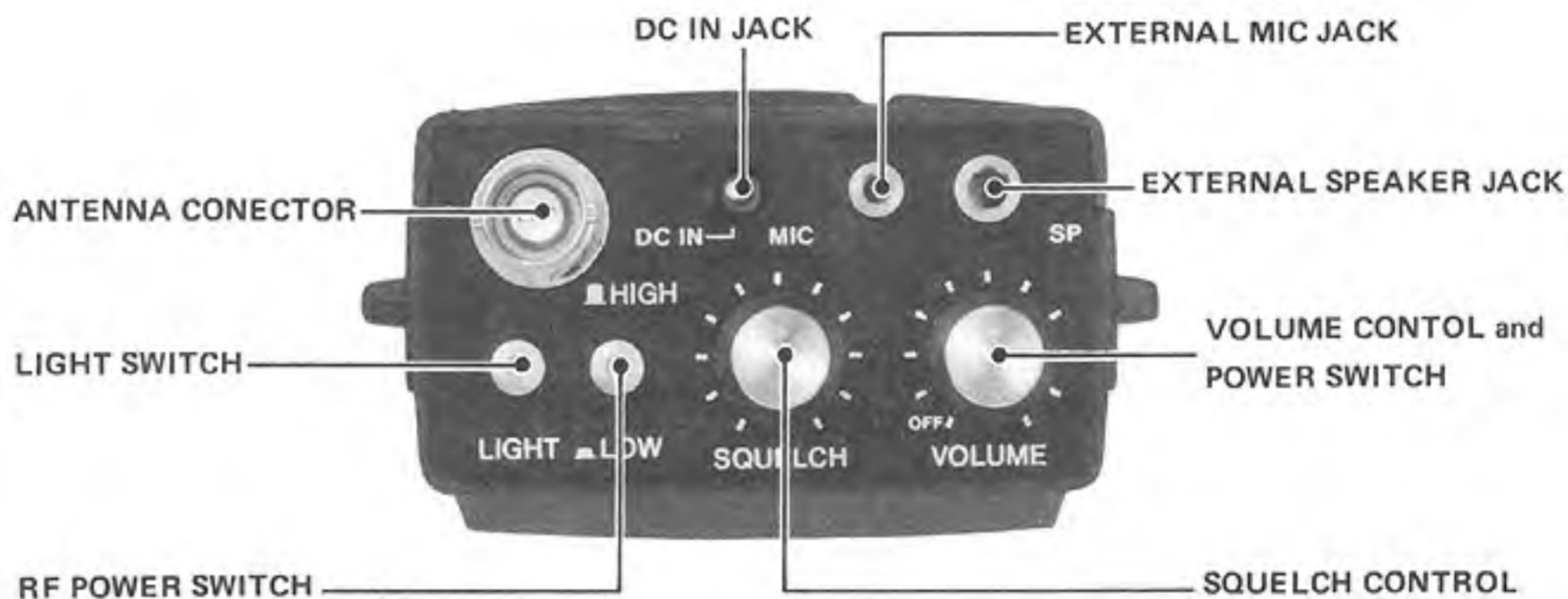

FRONT VIEW

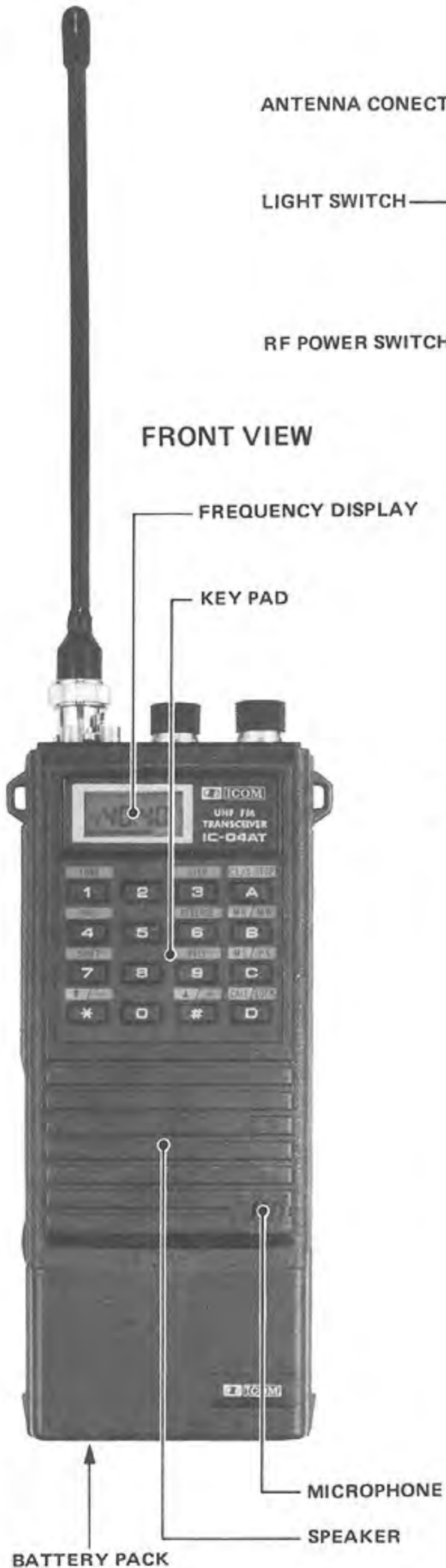

REAR VIEW

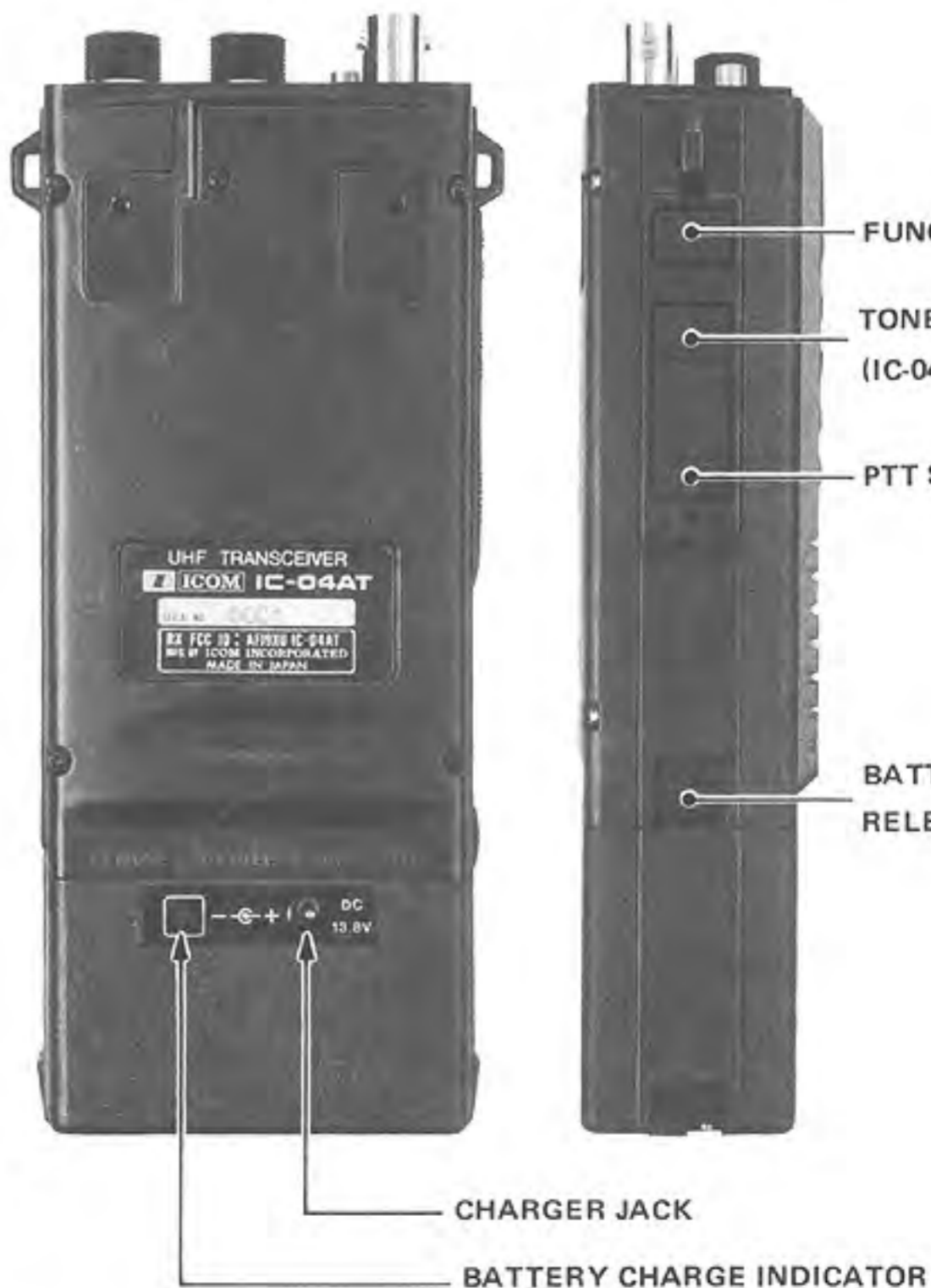

SIDE VIEW

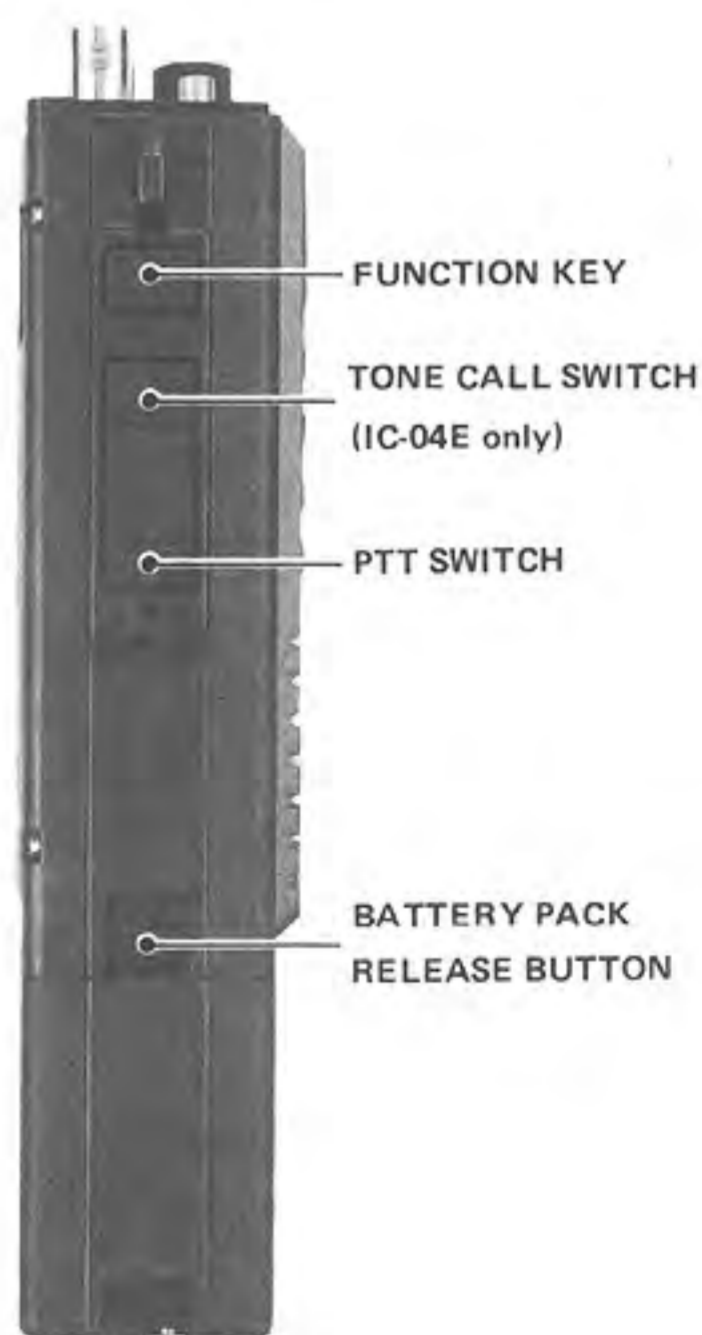

2-2 INSIDE VIEWS

MAIN UNIT

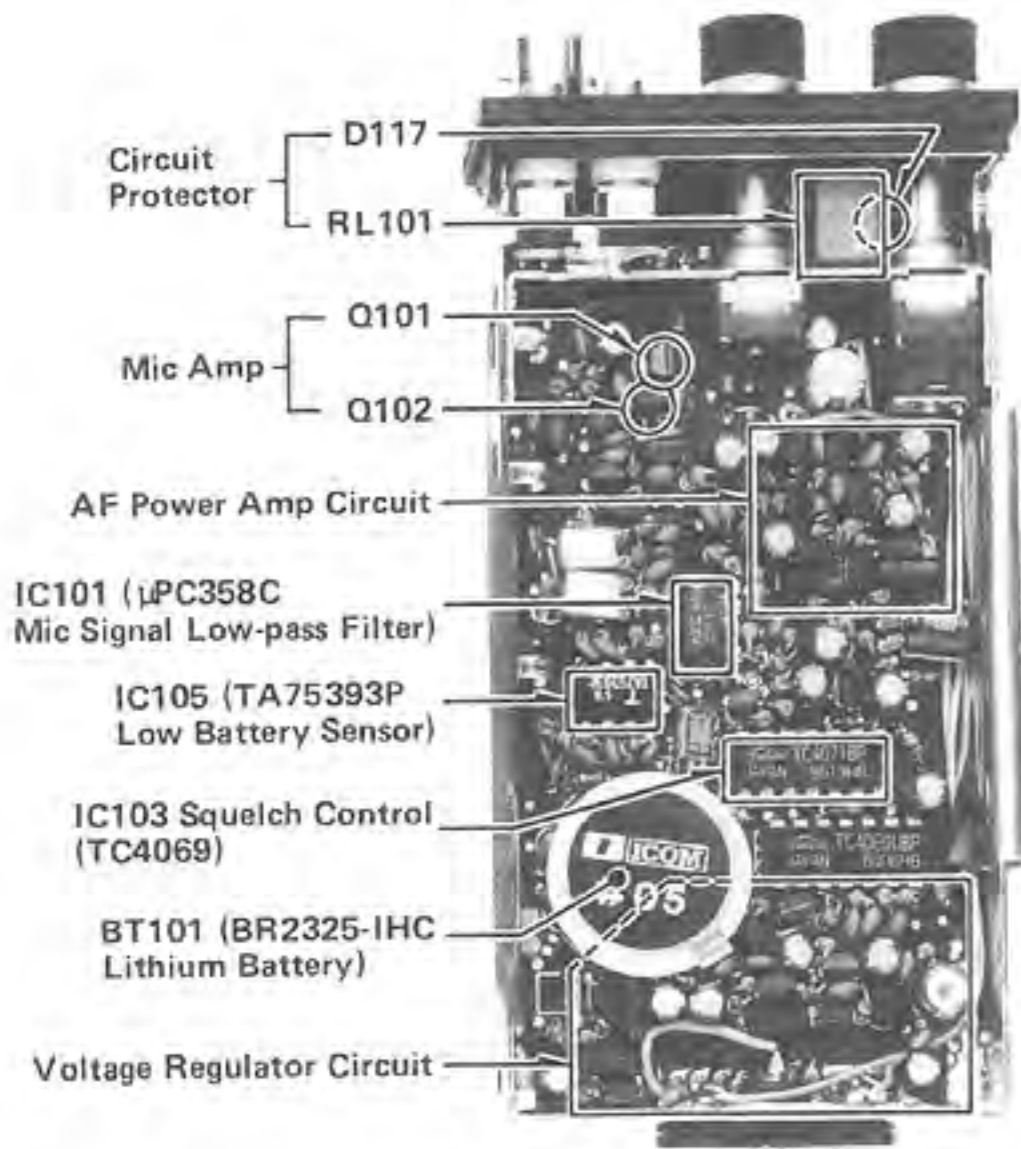

PLL UNIT

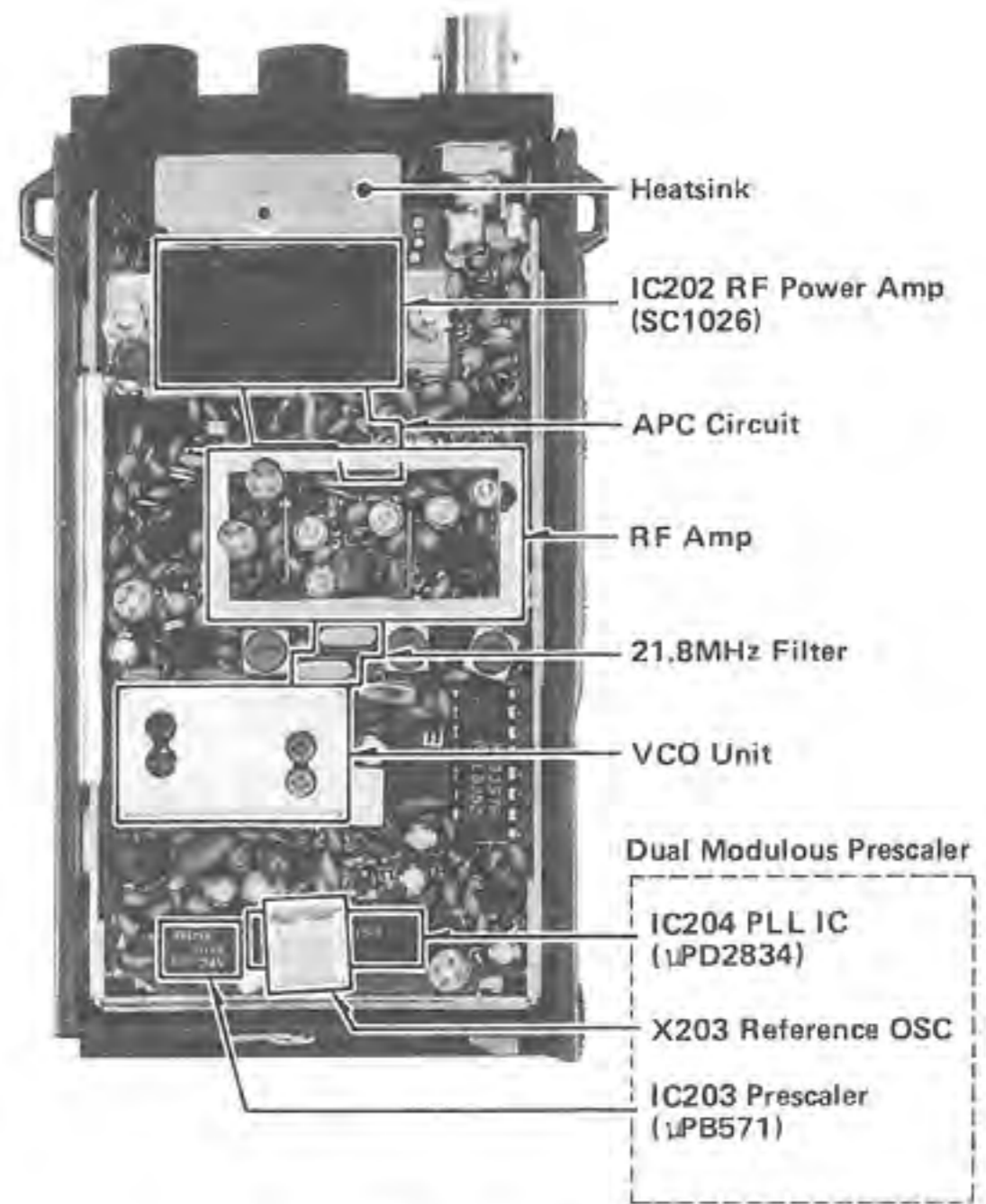

LOGIC UNIT

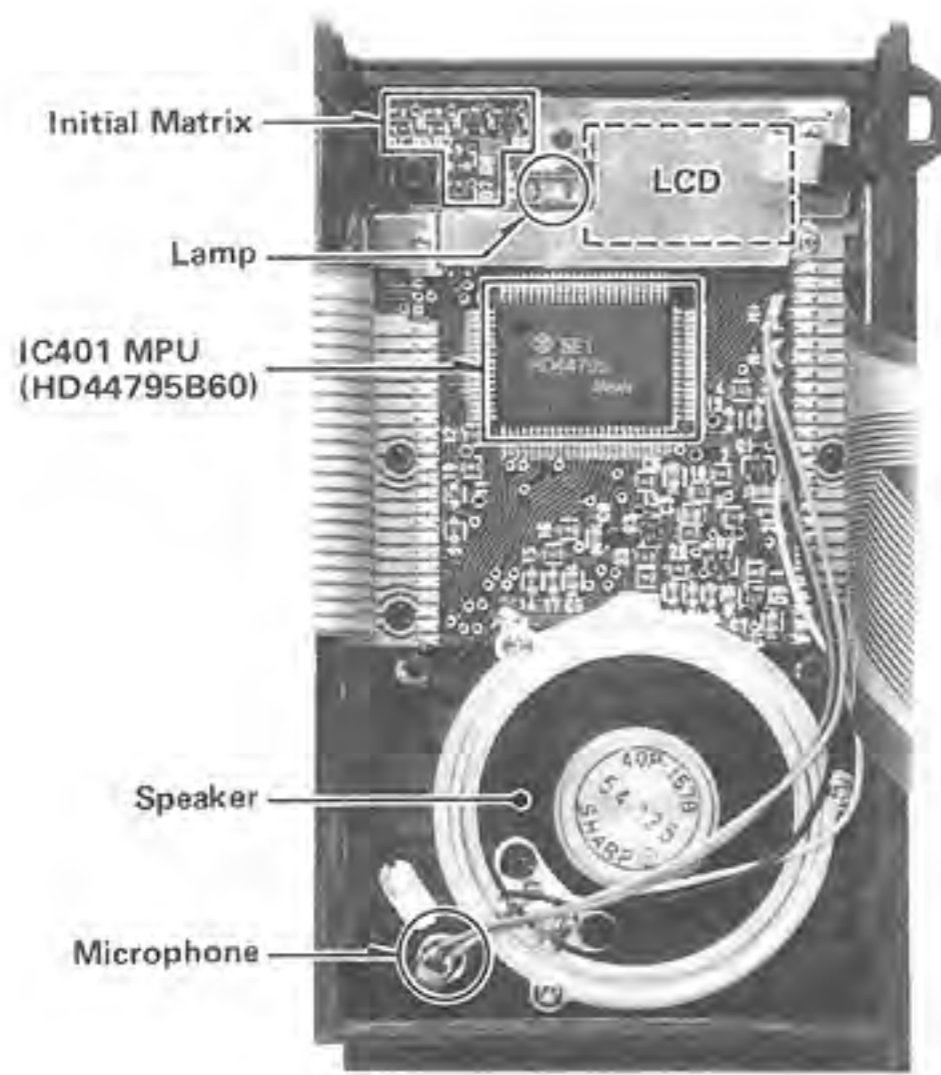

TONE UNIT (IC-04AT only)

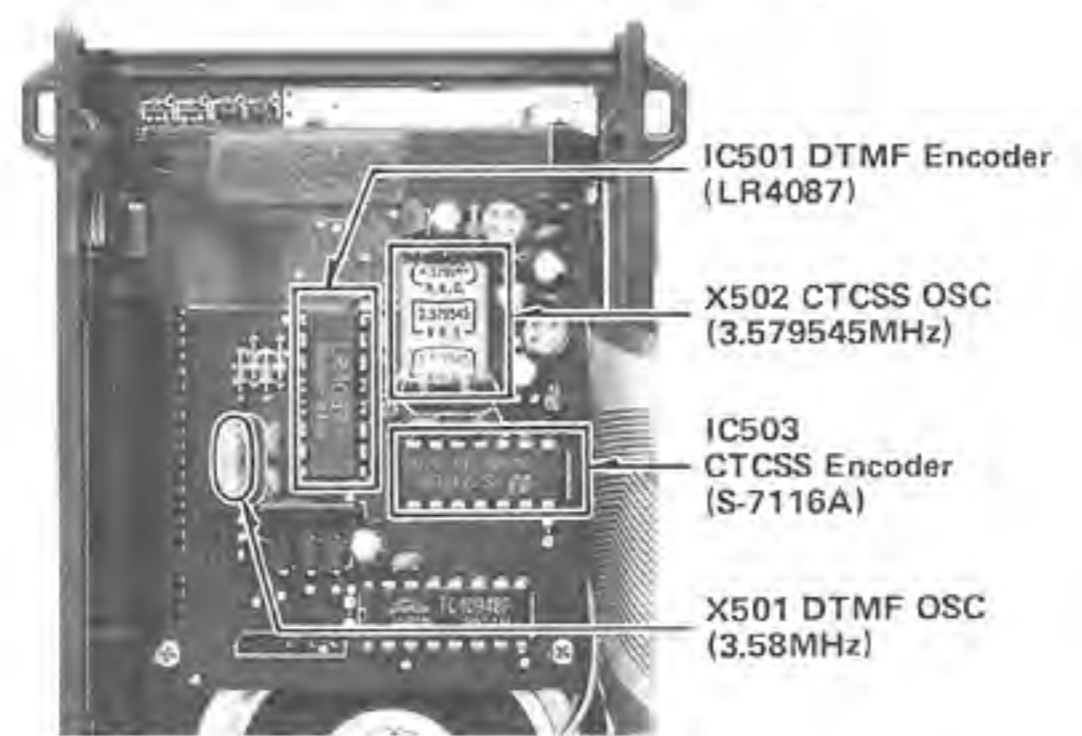

TONE CALL UNIT (IC-04E only)

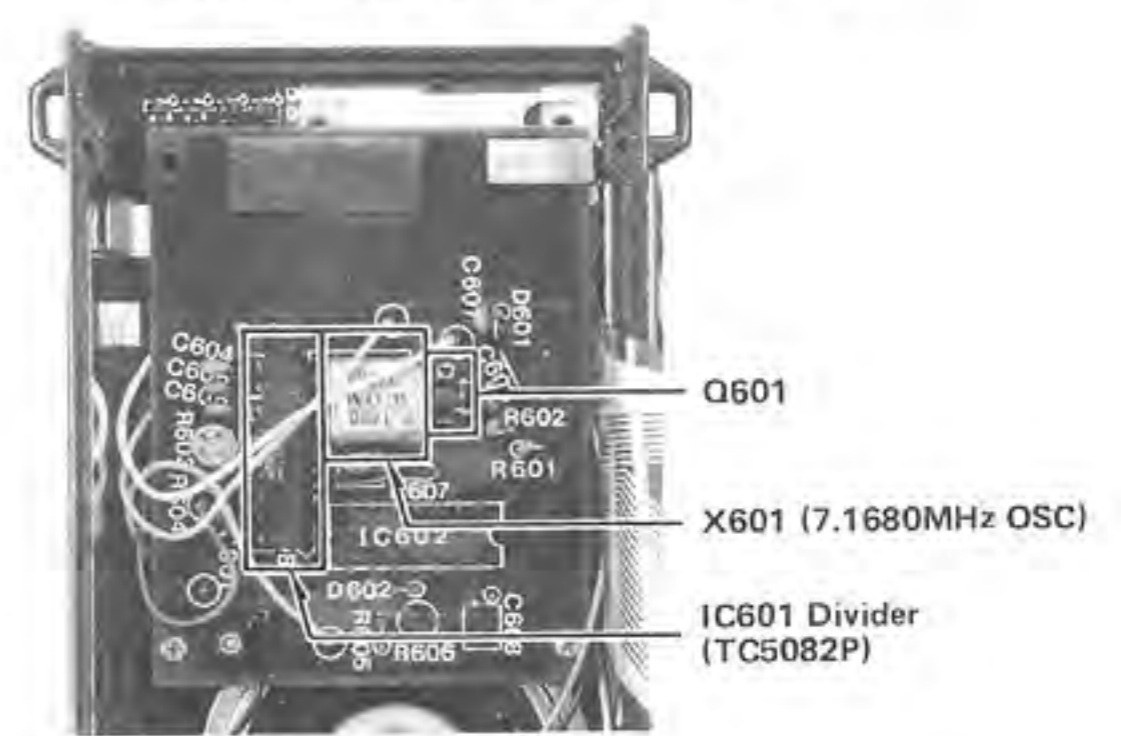

SECTION 3 BLOCK DIAGRAM

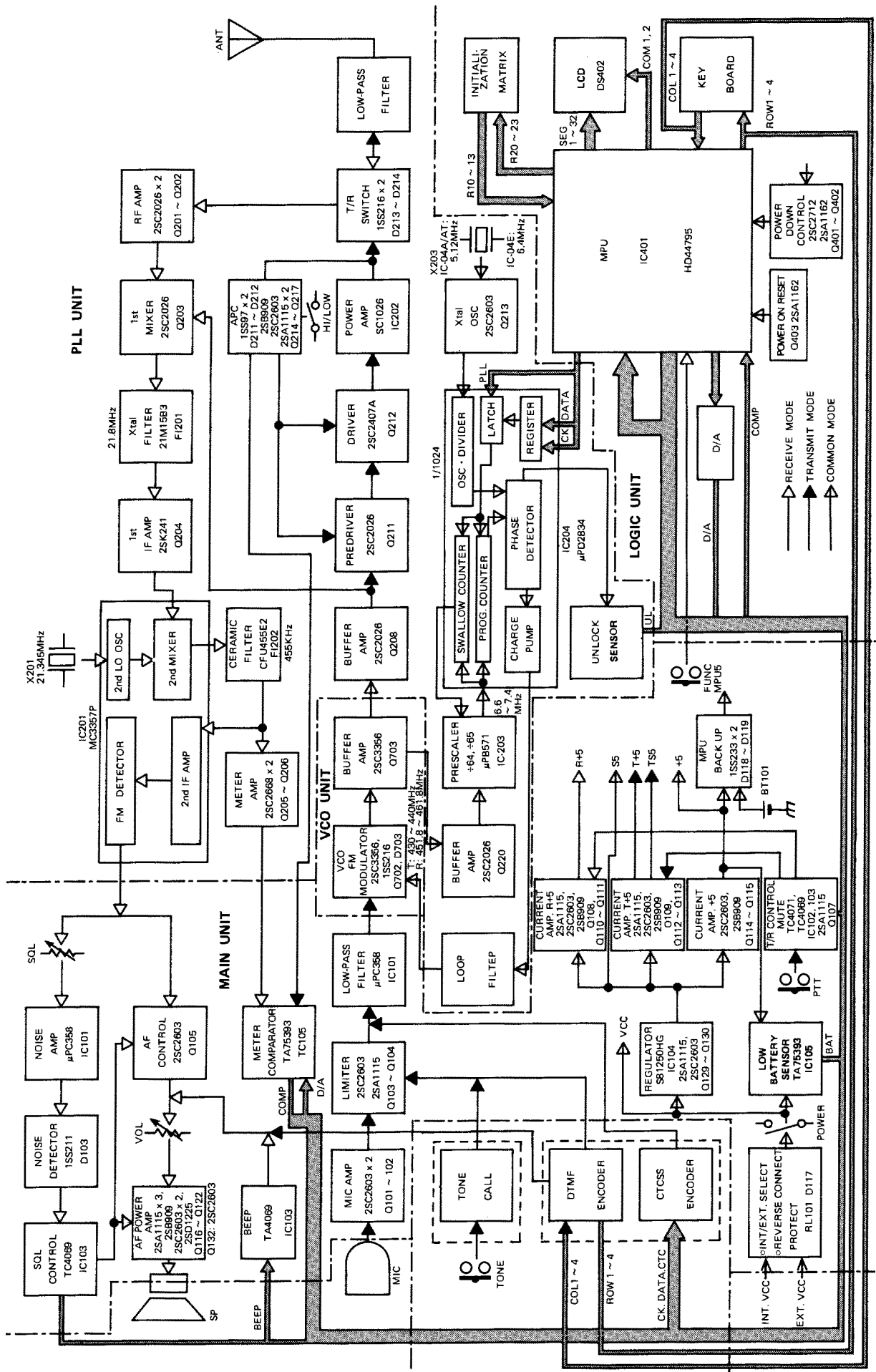

SECTION 4 CIRCUIT DESCRIPTION

4-1 RECEIVER CIRCUITS

4-1-1 ANTENNA SWITCHING CIRCUIT (PLL UNIT)

Receive signals enter the PLL UNIT from ANTENNA CONNECTOR J201 and pass through a Chebyshev low-pass filter consisting of L223, L224, and C289~C291. The antenna switching circuit employs a $4/\lambda$ -type diode switching system which does not allow current to flow while receiving.

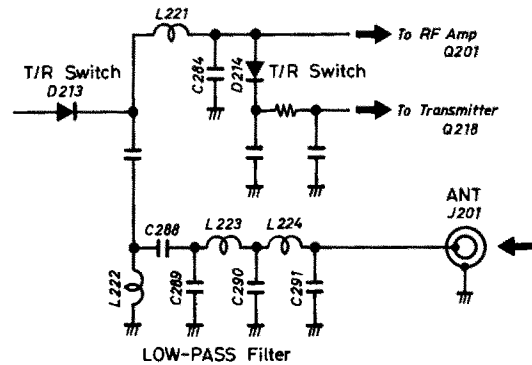

4-1-2 RF CIRCUIT (PLL UNIT)

The receive signals from the antenna switching circuit pass through a bandpass filter consisting of C202, C203 and L201, and are amplified at RF amplifiers Q201 and Q202. Bandpass filters are designed for the after stage of each RF amplifier circuit to further suppress out-of-band signals.

After passing through the bandpass filter, signals are fed to 1st mixer Q203 for conversion to 21.8MHz 1st IF signals with LO signals from the PLL circuit.

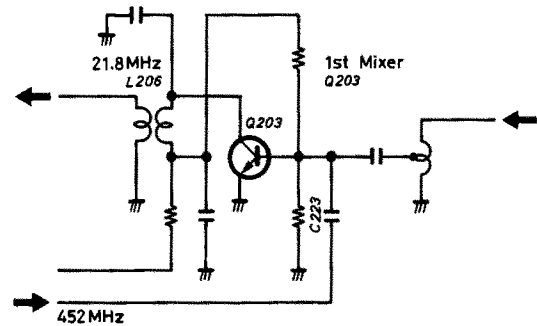

4-1-3 IF CIRCUIT (PLL UNIT)

1st IF signals from Q203 pass through a pair of crystal filters (FI201) to suppress out-of-band signals and unwanted heterodyned frequency signals. After passing through the filter, the 1st IF signals are amplified at IF amplifier Q204, pass through matching coil L208, and are fed to IC201.

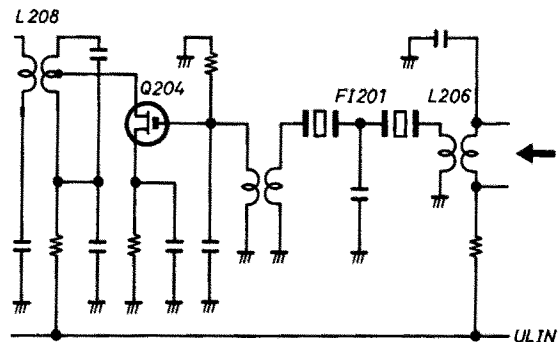

IC201 contains the 2nd LO circuit, 2nd mixer circuit, limiter amplifier circuit and quadrature detector circuit. The 2nd LO circuit and X201 generate 21.345MHz 2nd LO signals which are used at the 2nd mixer section of IC201.

1st IF signals from L208 are fed to pin 16 of IC201, and are mixed with 2nd LO signals for converting the 1st IF signals to 455kHz 2nd IF signals.

The 2nd IF signals are output from pin 3 and pass through high-quality ceramic filter FI202 to suppress unwanted heterodyned frequency signals. They are then amplified at the limiter amplifier section (pin 5 of IC201) and applied to a quadrature detector circuit (the quadrature detection section of IC201) and ceramic resonator X202 to demodulate 2nd IF signals to AF signals.

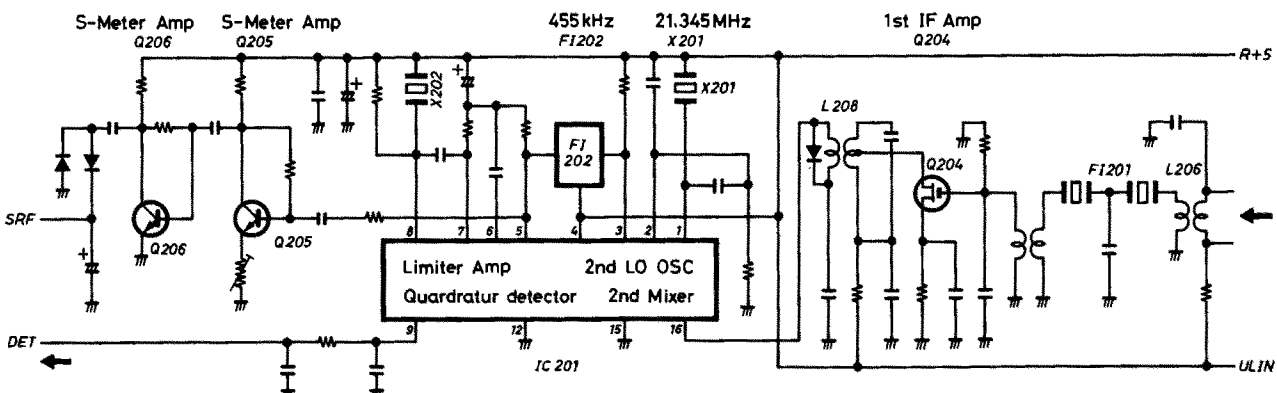

4-1-4 S-METER CIRCUIT (PLL UNIT)

A portion of signals passed from FI202 is amplified at S-meter amplifier Q205 and Q206, and is detected at voltage doubler rectifiers D201 and D202. These signals are then applied to meter comparator IC105A on the MAIN UNIT.

4-1-5 AF CIRCUIT (MAIN UNIT)

AF signals output from pin 9 on IC201 are applied to the MAIN UNIT, and pass through a de-emphasis circuit consisting of R127 and C117. These signals are then amplified at AF controller Q105. This de-emphasis circuit is an integrator circuit with frequency characteristics of 6dB/oct.

The AF amplifier circuit consists of Q116~Q122. The input section (Q116 and Q117) functions as a differential amplifier to ensure stable operations and a suitable frequency response by the negative feedback network of R152 and R149. The AF power amplifier circuit is a complementary SEPP circuit with a Darlington connection of Q119~Q122. This circuit drives the speaker.

When the power source voltage is more than 10V, D106 and voltage regulator Q106 limit output voltage and output power, stabilizing the bias.

A standby current suppressor (Q132) is installed to suppress the current and residual noise while the squelch is closed.

4-1-6 SQUELCH CIRCUIT (MAIN UNIT)

Noise components from pin 9 of IC201 are fed to active filter IC101B through SQUELCH CONTROL R126.

This active filter is a high-pass filter, and amplifies approximately 20kHz noise components. The noise components are then rectified by D103 and converted to DC voltage at R119, R120, C111, and C112. The DC voltage passes through inverters IC103B and IC103A to obtain a TTL level from a linear level.

AF controller Q105 is turned OFF by the "HIGH" voltage level from pin 2 of IC103A. Output signals from pin 2 of IC103A are also fed to MPU IC401 in the LOGIC UNIT through D104 as a squelch signal.

When no RF signal is received, noise rectified output voltages from D103 are "HIGH". Pin 2 of IC103A thus becomes "HIGH" and Q105 turns OFF. AF output is then cut OFF.

In transmit mode, T + 5 signals are applied to pin 9 of IC103B via D105 to turn Q105 OFF.

4-1-7 1st LO CIRCUIT (VCO AND PLL UNITS)

450MHz band LO signals from the VCO UNIT are buffer amplified at Q208 and fed to transmit/receive switching circuit D208 in the PLL UNIT. The signals are then applied to the base of 1st mixer Q203 as 1st LO signals.

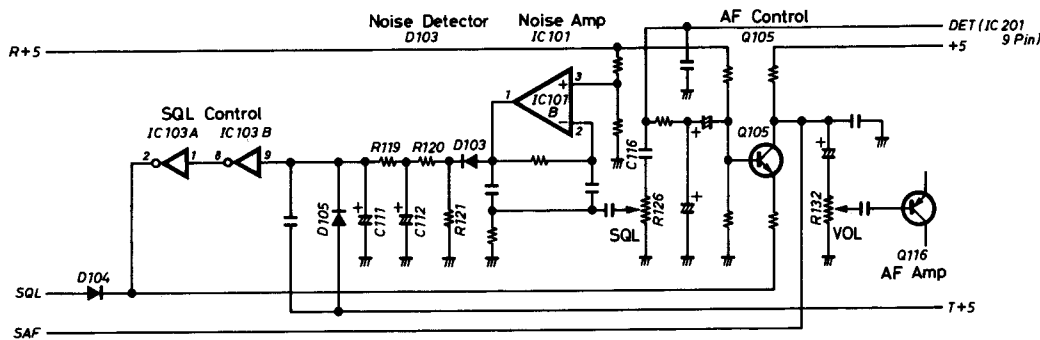

4-2 TRANSMITTER CIRCUITS

4-2-1 MICROPHONE AMPLIFIER CIRCUIT (MAIN UNIT)

AF signals from the INTERNAL MICROPHONE or from EXTERNAL MIC JACK J202 are amplified at a limiter amplifier consisting of Q101~Q104.

This limiter amplifier is formed by a negative feedback circuit with frequency characteristics set at 6dB/oct. from 300Hz to 3kHz. This causes the limiter amplifier to function as a pre-emphasis circuit. Output from the limiter amplifier is similar to a rectangular waveform and includes harmonic components.

Harmonic components higher than 3kHz are attenuated by splatter filter IC101A.

AF signals from IC101A pass through modulation adjusting trimmer pot R226 in the PLL UNIT and are then applied to the anode of D703 in the VCO UNIT for performing frequency modulation.

4-2-2 BUFFER AMPLIFIER CIRCUIT (PLL UNIT)

430 or 440MHz band signals output from the VCO UNIT are buffer amplified by Q208 and pass through transmit/receive switching circuit D209. They are then amplified at predriver Q211, and driver Q212, thus obtaining a wideband of 150mW.

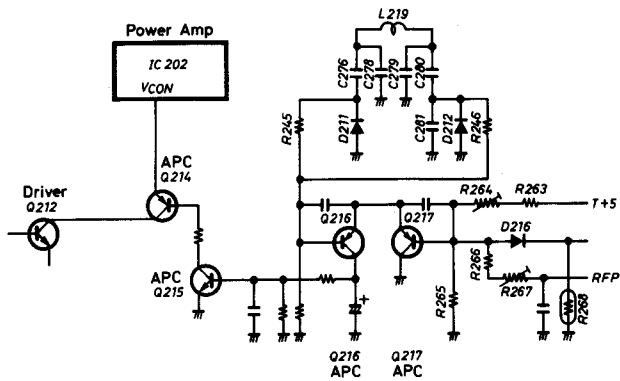
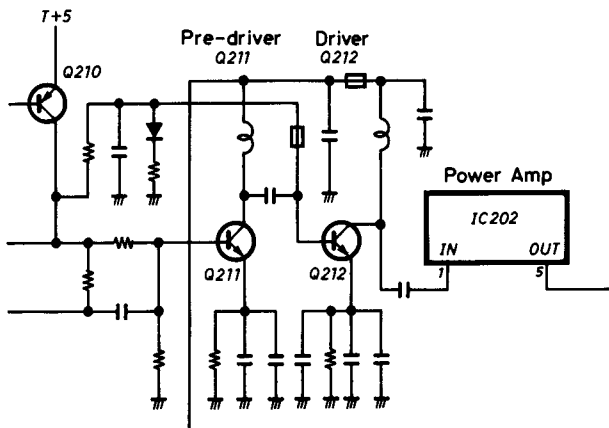

4-2-3 POWER AMPLIFIER CIRCUIT

Amplified signals at Q212 are power-amplified at IC202.

IC202 is a small-sized power module giving stable output power of more than 5W with a driving power of 150mW. The output power from IC202 is passed through the APC detector circuit, the antenna switching circuit, a low-pass filter, and then applied to the ANTENNA CONNECTOR.

While transmitting the antenna switching circuit consisting of Q218, D213 and D214 is turned ON and L221 and C284 become parallel resonance circuits to prevent signals being applied to the receiver circuits.

Q210 controls the bias voltage of Q211, Q212 and IC202 to prevent unwanted emissions when switching from receive to transmit mode, or when the PLL circuits are unlocked.

4-2-4 APC AND POWER SET CIRCUITS (PLL UNIT)

The APC detector circuit consists of L219, D211 and D212. When antenna impedance is matched at 50Ω, voltage detected at D211 and D212 has a minimum value. However, when antenna impedance is in a mismatched condition, the detected voltage becomes higher than it is in the matched condition.

Q216 and Q217 form the differential amplifier circuit. The base bias of Q217 (reference voltage) is determined by R263, R264 and R265.

The voltage detected at D211 and D212 is combined by R245 and R246, and fed to the base of Q216.

When the antenna is mismatched with the transceiver the base voltage of Q216 is higher than the base voltage of Q217. The Q216 collector current and Q215 base current are then reduced, decreasing the Q214 collector current. This decreases the output power of Q211 and Q212 until the base voltage of Q216 becomes the same as the base voltage of Q217.

In a matched condition, RF POWER SWITCH S105 is in the "HIGH" position and RF output power can be adjusted by R264. In the "LOW" position a series combination of R267 and R266 is connected in parallel with R265. RF output power can then be adjusted by R267.

The output voltage detected at D211 and D212 passes through R272 and is applied to meter comparator IC105A on the MAIN UNIT.

4-3 PLL CIRCUITS

The PLL circuits adopt a dual modulus prescaler system. The circuits generate the desired frequency directly in the VCO circuit.

The PLL circuits are composed of prescaler IC203 and PLL IC IC204.

N data is the number of times desired frequency is divided by the reference frequency. The desired frequency is transmit frequency in transmit mode and the 1st LO frequency in receive mode.

$$N\text{-data} = \frac{\text{Desired frequency}}{\text{Reference frequency}}$$

4-3-1 REFERENCE FREQUENCY CIRCUIT (PLL UNIT)

IC204 incorporates a swallow counter of 6 binary bits, a programmable counter of 11 binary bits, a phase comparator, a charge pump and a frequency divider for the reference frequency.

A 5.12MHz (#04 6.4MHz) signal is oscillated at reference oscillator Q213 and X203, and is fed to pin 17 of IC204. IC204 divides the frequency by 1/1024 and a reference frequency of 5kHz (#04 6.25kHz) is obtained. The reference frequency is fed to pin 8 of IC203.

4-3-2 DUAL MODULUS PRESCALER

Signals from the VCO UNIT are buffer amplified at Q220 and divided N times at IC203 and IC204. Signals are then phase detected at IC204 and the detected signals are output from pin 11.

IC202 is a prescaler that divides signals generated by the VCO UNIT by either 1/64 or 1/65.

4-3-3 LOOP FILTER, VCO, MODULATION CIRCUITS (PLL AND VCO UNITS)

Output from pin 11 of IC204 determines the characteristics of the PLL circuits through a lag lead type loop filter consisting of R248, R249 and C294. This output controls D701 in the VCO UNIT.

The VCO (Q702) employs a Colpitts oscillator circuit. The VCO free run frequency is shifted by inductive capacitance with Q701 and D702.

In receive mode, Q701 turns OFF then the free run frequency is determined by L703, C703 and C702. In transmit mode, Q701 turns ON then D702 is activated. Thus C706 and C705 are parallel connected with C702 and C703. As a result the free run frequency is shifted lower than receive frequency.

Stable oscillation is controlled by varactor diode D701 and is achieved over a wide frequency range.

While the transceiver is transmitting, modulation signals are applied to the anode of D702, changing its capacitance performing frequency modulation.

4-3-4 UNLOCK CIRCUIT (PLL UNIT)

When the PLL circuit is unlocked, pin 10 of IC204 is "LOW" and a "LOW" signal is fed to pin 8 of IC102A as unlock signals through a time constant circuit consisting of R251 and C296.

In transmit mode pin 9 of IC102A is "LOW" thus unlock signals are applied to the MPU from pin 10 of IC102A.

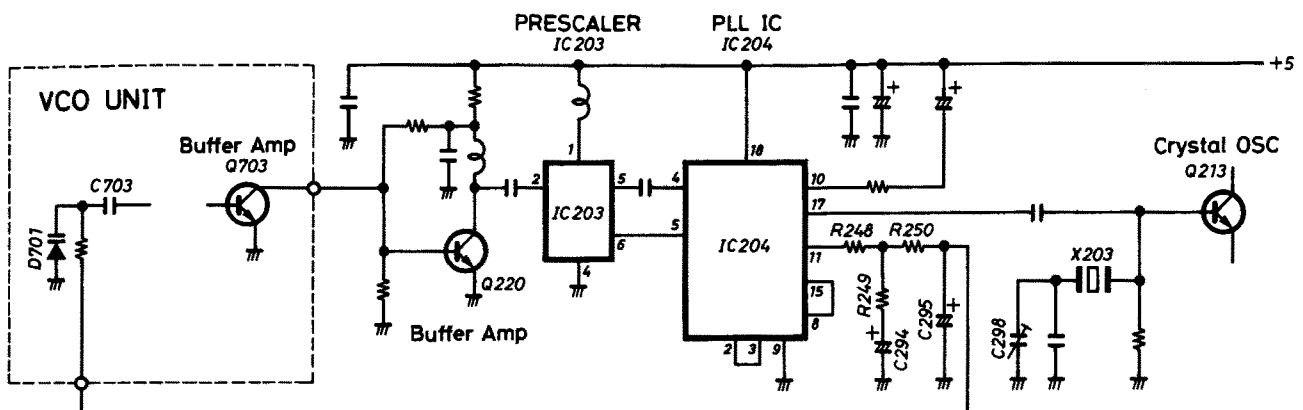
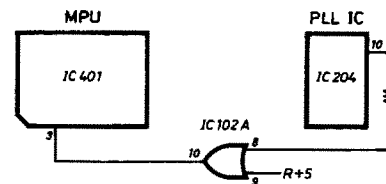

4-4 POWER SUPPLY CIRCUIT

4-4-1 INTERNAL/EXTERNAL POWER SWITCHING CIRCUIT (MAIN UNIT)

When using an attached battery pack, relay RL101 is OFF and POWER SWITCH R132 is connected to the battery pack. When a power source with voltage between 10~16V is connected to EXTERNAL DC POWER JACK J203, RL101 is ON and R132 is connected to the external power source.

In case a wrong connection to J203 is made with reverse polarity, D117 is reversely biased, preventing RL101 from being ON and protecting the transceiver.

4-4-2 VOLTAGE REGULATOR CIRCUITS (MAIN UNIT)

A three terminal voltage regulator (IC104) keeps the output voltage at 5V constantly even when input voltage is from 5.1V to 16V.

Noise components are eliminated from the output of IC104 through a filter circuit consisting of R165 and C138. Output from the filter circuit is fed to a current amplifier circuit consisting of Q129 and Q130.

Q129 and Q130 are connected in a complementary circuit for a higher current amplification factor. The base voltage of Q130 is nearly equal to the output voltage of IC104. Also, the collector voltage of Q129 is approximately 5V. As the temperature coefficient of the junction voltage of D114 is nearly equal to the V_{BE} of Q130, the output voltage is kept constant against any change in temperature.

The regulated 5V from the collector of Q129 is fed to common circuits through current amplifier circuit Q114 and Q115, and is also fed to transmit/receive switching circuit Q108 and Q109.

In receive mode, pin 3 of IC103 is "LOW" and Q108 is turned ON to feed R+5 through current amplifier Q110 and Q111. At this time, Q109 is turned OFF.

In transmit mode, pin 3 of IC103 is "HIGH" and pin 4 of IC103 is "LOW". Q108 is turned OFF and Q109 ON. Thus Q109 feeds T+5 through current amplifiers Q112 and Q113.

4-4-3 MPU POWER SOURCE CIRCUIT (MAIN UNIT)

When the battery pack is removed from the transceiver, a voltage is applied to MPU IC401 in the LOGIC UNIT via D119 from LITHIUM BACKUP BATTERY BT101 to provide backup for the memory contents.

4-4-4 VOX POWER SOURCE CIRCUITS (PLL UNIT)

The current limiter circuit consists of Q219, D217, R273, R274 and R275. This circuit has a current limit of maximum 5mA and supplies a voltage to the optional HS10SA VOX UNIT.

When the current is overloaded Q219 reduces the current until the base voltage of Q219 plus V_{BE} and the emitter voltage of Q219 are the same.

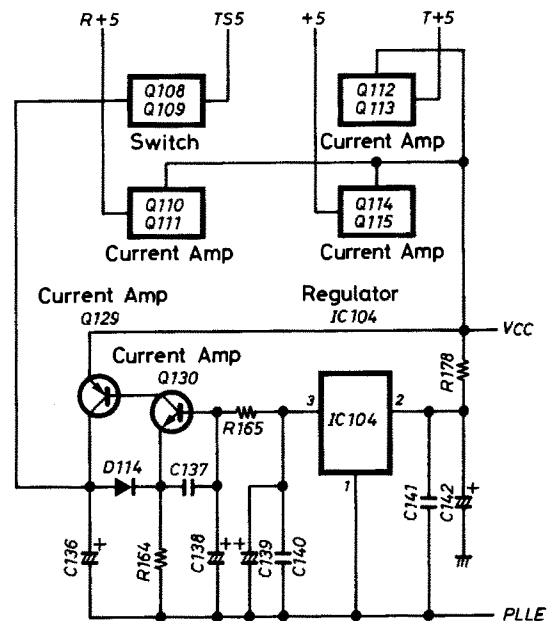

4-5 COMPARATOR, REDUCED VOLTAGE DETECTION CIRCUITS

4-5-1 COMPARATOR CIRCUIT (MAIN UNIT)

The voltage detected in the S meter circuit or APC circuit is input to pin 3 of IC105A. D/A signals from the MPU are fed to pin 2 of IC105A.

The MPU counts up and outputs 4 bit digital signals until pin 2 of IC105A becomes higher than pin 3. These signals are converted to an analog signal with R409 R412 in the LOGIC UNIT. The signals are divided at R166 and R179 in the MAIN UNIT and changed to 16 step D/A signals between 0.12V and 1.258V.

When the voltage at pin 2 of IC105A is higher than pin 3, the output at pin 1 is "LOW" and applied to the MPU as the COMP signal. The MPU indicates the counting number to the S/RF INDICATOR as the signal strength in receive mode and as RF output power in transmit mode.

4-5-2 REDUCED VOLTAGE DETECTING CIRCUIT (MAIN UNIT)

The reduced voltage detecting circuit consists of IC105B, R168, R169, and R171.

A regulated 5V is divided at R168 and R169 and a voltage of approximately 1.03V is applied to pin 6 of IC105B. The voltage of the Vcc is divided by R170 and R171, and is applied to pin 5. The voltage division ratio is selected so that the voltage at pin 5 is 1.03V when the Vcc is approximately 5.6V.

If the Vcc is greater than 5.6V, the voltage at pin 5 of IC105B is higher than that at pin 6. Pin 7 then becomes "HIGH". If the Vcc voltage decreases to less than 5.6V, the voltage at pin 5 is less than that at pin 6 and the output voltage at pin 7 and the output of IC105B is "LOW". This information is fed to MPU IC401, causing the BATTERY CONDITION INDICATOR to appear on the FREQUENCY DISPLAY.

4-6 LOGIC CIRCUITS

The main part of the logic circuits is MPU IC401. This includes a 2k word ROM, 128 word ROM, 160 byte RAM, and a circuit to drive FREQUENCY DISPLAY DS401.

The next 4-7 page allocation is an explanation of operations and their I/O ports.

4-7 OTHER CIRCUITS

4-7-1 LAMP CIRCUIT (MAIN UNIT)

The lamp circuit consists of Q131, D115, D116, and other components and drives backlight DS401 at a constant current, ensuring that brightness does not change even with a change of power supply voltage.

When S106 is turned ON current flows into R173, resulting in the base voltage of Q131 being approximately Vcc 1.2V as determined by D115 and D116. The emitter voltage of Q131 is then Vcc 0.6V and the voltage at both ends of R172 is kept constant. The result is a constant current even with a change of power supply voltage.

4-7-2 BEEP CIRCUIT (MAIN UNIT)

This is a phase shift oscillator consisting of IC103F, R155~R158, C131, C132, and C134. The circuit oscillates when the cathode of D113 becomes "HIGH". The oscillating frequency is set at approximately 2500Hz.

4-7-3 TRANSMIT/RECEIVE SWITCHING CIRCUIT (MAIN UNIT)

When PTT SWITCH S101 is pushed, Q107 turns ON and pin 13 of IC103C and pin 1 of IC102 become "HIGH". Pin 2 of IC102C remains "LOW" for approximately 20msec. via time constant circuits R138 and C122. After 20msec. pin 2 of IC102C becomes "HIGH", and then pin 3 of IC102C becomes "HIGH". Thus Q108 is turned OFF and Q109 is turned ON, then the T + 5 and TS5 lines become 5V. "Transmit mode" information is sent to the MPU from pin 12 of IC103C via D107 with no delay time.

MUTE signals from IC401 are "HIGH" and applied to pin 13 of IC102D from MPU IC401 for approximately 60msec. to mute RF output signals, preventing unstable signals from using Q210 in the PLL UNIT.

When S101 is released after 20msec, pin 3 of IC102C is "LOW" and turns Q108 ON and Q109 OFF.

4-7-4 DTMF ENCODER CIRCUIT (TONE UNIT) (#05 version only)

IC501, the DTMF encoder, generates Dual Tone Multi-Frequencies. While transmitting, Q505 turns ON, applying voltage to IC501. If any keys on the KEYBOARD are pushed at this time, the proper frequency dividing ratio for the dividing frequency of X501 (3.58MHz) is selected to output one set of audio frequencies corresponding to row input and column input from pin 16 of IC501.

Also, a "HIGH" level is applied from pin 10 of IC501 when the KEYBOARD is activated. This level has a time constant of approximately 1msec for turning Q506 ON. Thus key entries can be made without holding the PTT SWITCH down.

4-7-5 SUBAUDIBLE TONE ENCODER CIRCUIT (TONE UNIT) (#05 and #09 versions)

When a tone number is set, data is sent to IC502 from MPU IC401 on the LOGIC UNIT. IC502 converts serial data from IC401 to parallel data, and feeds it to IC503. IC503 divides the frequency of X502 (3.579545MHz) corresponding to data, and outputs a subaudible tone from pin 1.

4-7-6 TONE CALL CIRCUIT (TONE UNIT) (#04 version only)

The TONE CALL UNIT generates a 1750Hz subaudible tone to open a repeater. When the TONE BURST SWITCH is pushed, Q601 turns ON and Vcc is applied to IC601. IC601 divides 7.1680MHz by 1/4096 and outputs 1750Hz from pin 4.

■ MPU PORT ALLOCATIONS

PORT NUMBER	PIN NUMBER	DESCRIPTION
D0 [SEND]	78	When this port is "LOW", the transceiver is in transmit mode and inhibits keyboard entry.
D1 [MUTE]	79	This port remains "HIGH" for approximately 60msec. when the transceiver is changed from receive to transmit mode.
D2 [CK]	80	This port outputs serial CK signals for the PLL and subaudible tone encoder circuits.
D3 [DATA]	1	This port outputs serial DATA signals for the PLL and subaudible tone encoder circuits.
D4 [COMP]	2	When this port is "LOW" the number of R3 ports is indicated on the S/RF INDICATOR.
D5 [UNLOCK]	3	When this port is "LOW" the D1 port is made "LOW" and "U" appears on the FREQUENCY DISPLAY.
D6 [PLL]	4	This port outputs a strobe signal for PLL N-data.
D7 [CTCSS]	5	This port outputs a strobe signal for the subaudible tone encoder.
D8 [SQL]	6	When this port is "LOW", scan functions are stopped and 2 dots light up on the S/RF INDICATOR.
D9[HALT CONT]	7	This port remains "LOW" for a few milliseconds when it turns power ON. It selects the address in the MPU and makes the HLT port "HIGH".
D10 [BEEP]	8	This port remains "HIGH" for 40msec. when the KEYBOARD is pushed to control the beep oscillator.
D11 [FUNC]	9	When this port is "LOW" the secondary key function is selected.
D12~D15[KEY SCAN]	10~13	These are output ports for keyboard scan and are connected to the columns of the KEYBOARD.
R0 [KEY RETURN]	14~17	These are input ports for the keyboard scan from ports D12~D15 and are connected to rows on the KEYBOARD.
R1 [INITIAL KEY RETURN]	66~69	These are input ports for the initial matrix key scan from ports R2 and determine frequency ranges, tuning step increments, etc.
R2 [INITIAL KEY SCAN]	70~73	These are output ports for the initial matrix key scan.
R3 [D/A]	74~77	These ports output a loop counter number in hexadecimal and count up until the COMP port receives a "LOW" signal to compare and read S/RF voltage.
INT0 [INT 0]	64	When the transceiver is turned OFF this port is "LOW" and the HALT CONT port remains "HIGH" for a few milliseconds.
INT1 [BAT]	65	When this port is "LOW", the BATTERY CONDITION INDICATOR lights up.
RESET [RESET]	18	When this port is "HIGH", the MPU is initialized.

SECTION 5 MECHANICAL PARTS AND DISASSEMBLY

PREPARATION

1. Turn the power switch OFF.
2. Remove the BATTERY PACK

5-1 REAR PANEL DISASSEMBLY

1. Remove the 4 flathead screws (M2.6 × 6 NI) and the battery pack sliding guide, battery pack latching plate, and battery pack release button from the bottom of the transceiver.
2. Remove panhead screw (M2 × 4 ZK) and 4 panhead tapping screws (M2 × 15 ZK) on the rear panel.

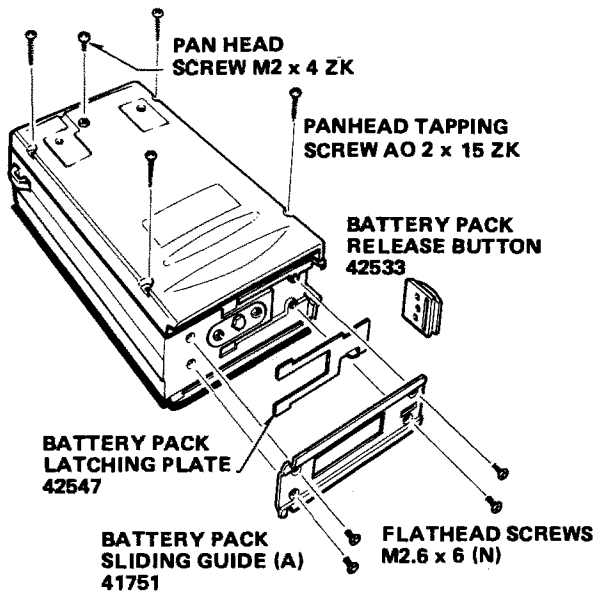

3. Remove the rear panel as shown in the figure.

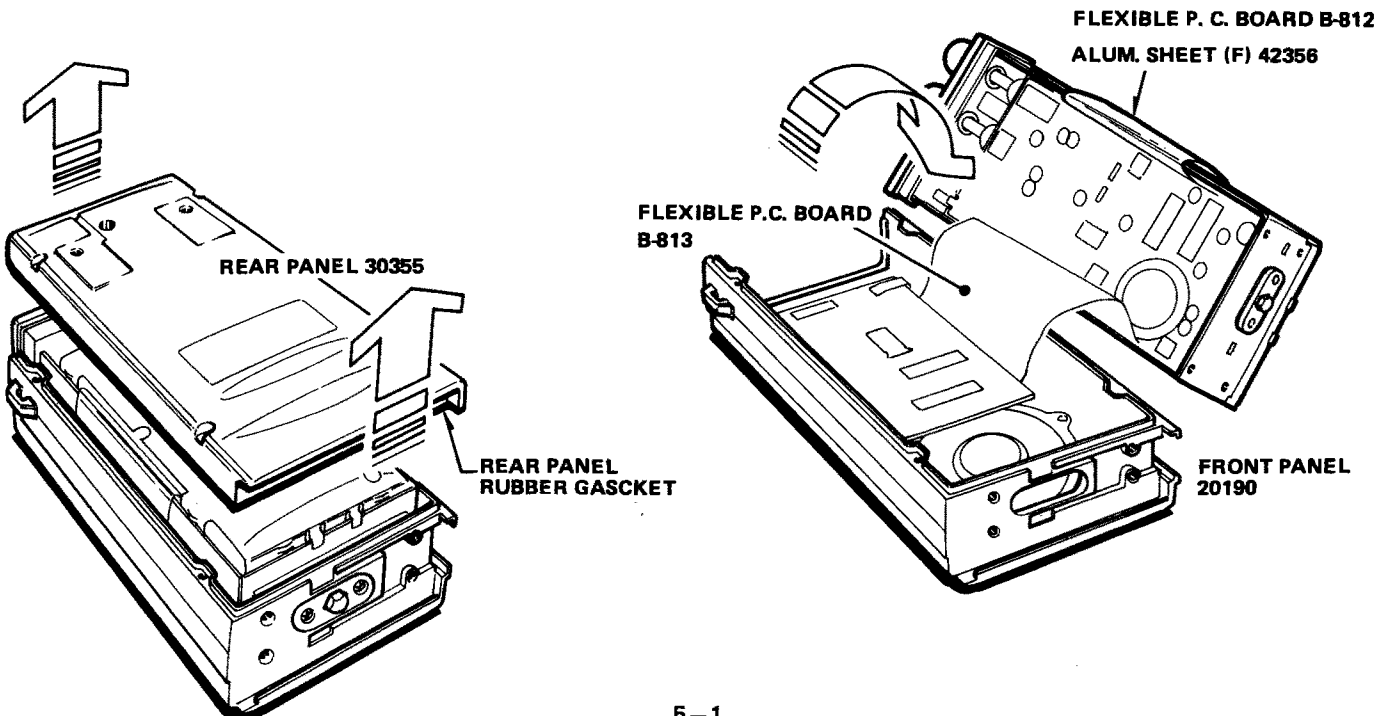

5-2 FRAME DISASSEMBLY

1. Slide the inner frame upward, and free the terminal holder from the front panel.

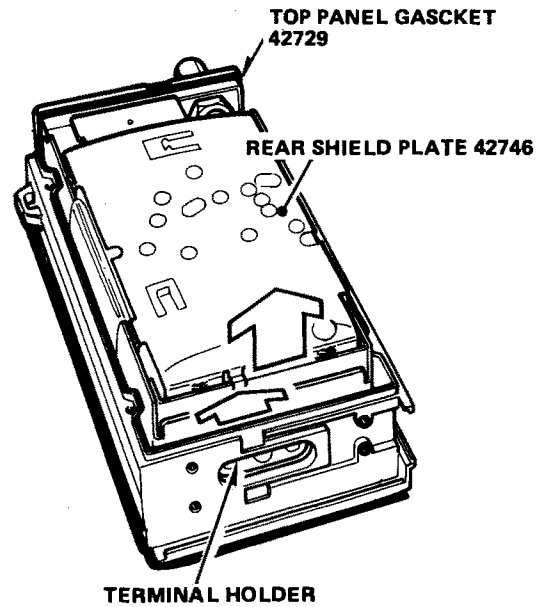

2. Lift the frame a way from the front panel and be sure not to damage the flexible P.C.Board when removing the front panel.

3. Remove the 2 panhead screws (M2 × 4 ZK).

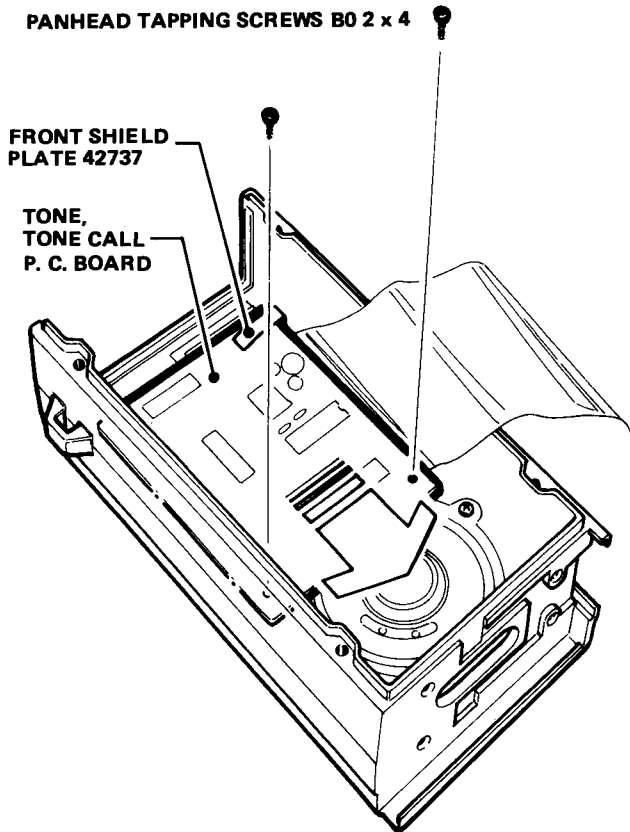

5-3 SOLDER SIDE DISASSEMBLY (MAIN, PLL UNITS)

1. Remove the two knobs (SQUELCH CONTROL, VOLUME CONTROL and POWER SWITCH)

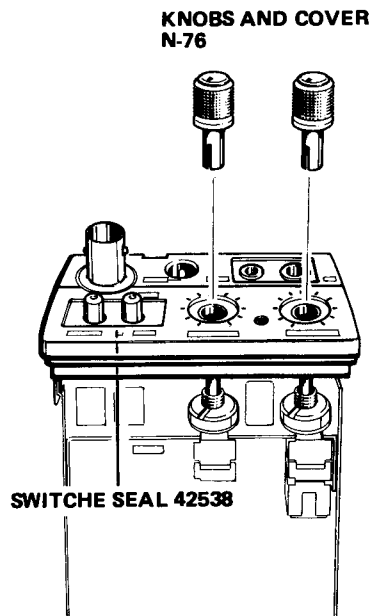

4. Remove the tone or tone call P.C. Board as shown in the figure.

2. Remove the 4 flathead screws (M2 × 4) on each side of the chassis.

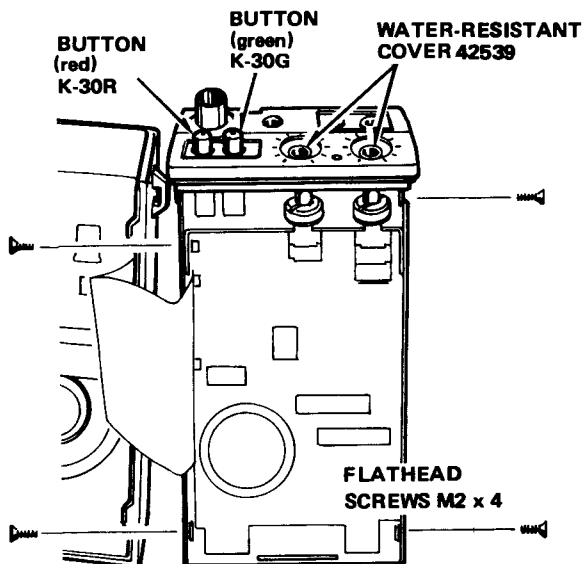
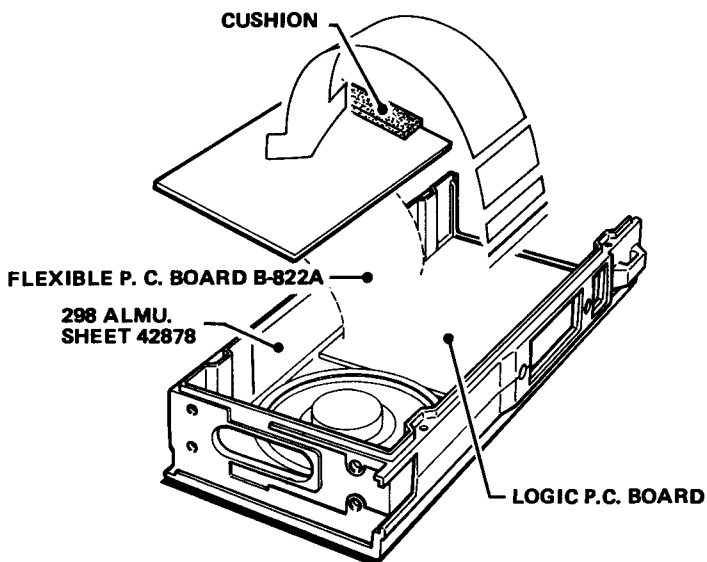

3. Open the transceiver slowly on the MAIN UNIT and PLL UNIT solder sides. Be sure not to damage the MAIN UNIT P.C. Board.

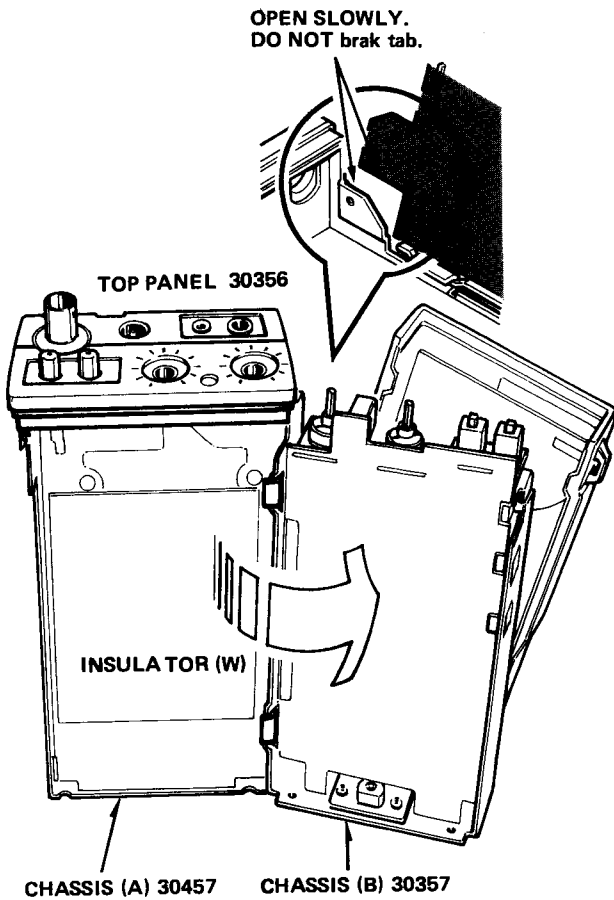

5-4 TOP PANEL DISASSEMBLY

1. Remove the panhead screw (M2 × 4 ZK).

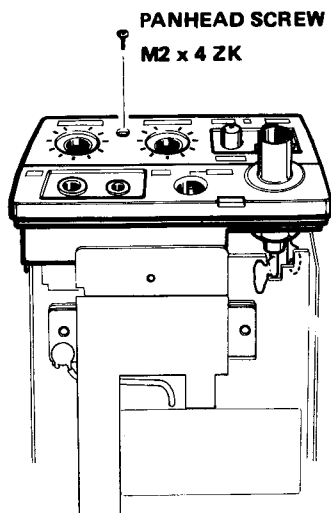

2. Unscrew and remove the BNC nut and BNC washer as shown in the figure.

Remove the ANTENNA CONECTOR by unsoldering point (A) on the components side and point (B) on the solder side of the PLL UNIT.

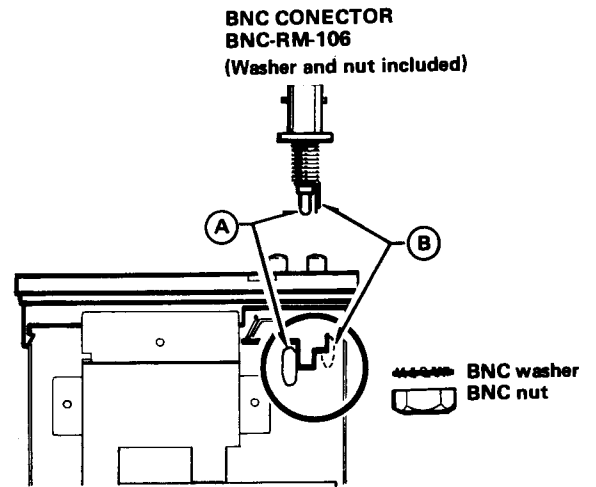

3. Remove the top panel by slightly prying it outward on both sides.

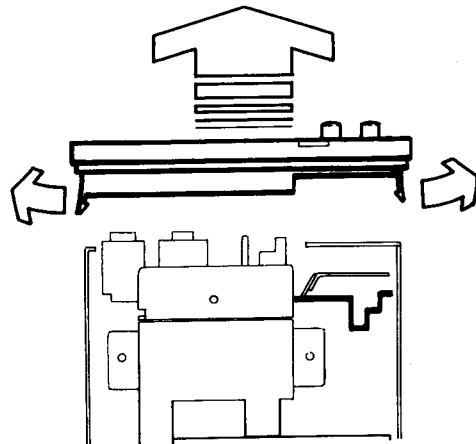

5-5 HEATSINK DISASSEMBLY

1. Remove the two panhead screws (M2.6 × 4 NI). Unsolder at (C) on the shield case.

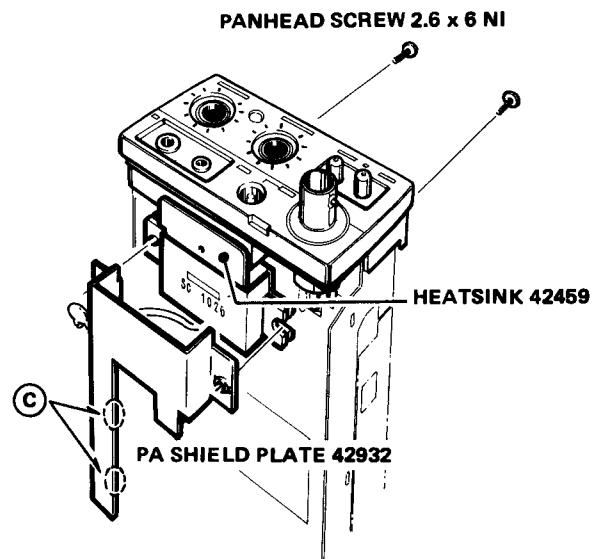

5-6 SPEAKER/MICROPHONE DISASSEMBLY

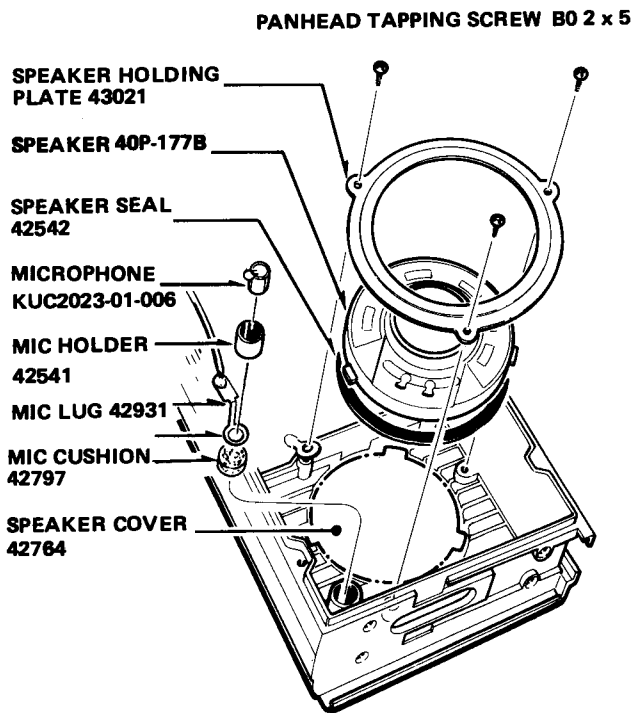

5-8 PTT PLATE AND PTT SEAL DISASSEMBLY

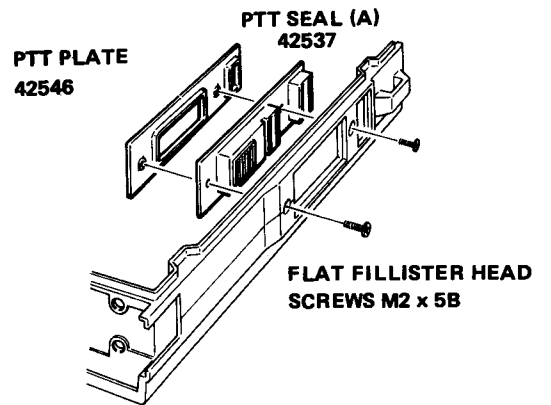

5-9 LOGIC UNIT AND LCD DISASSEMBLY

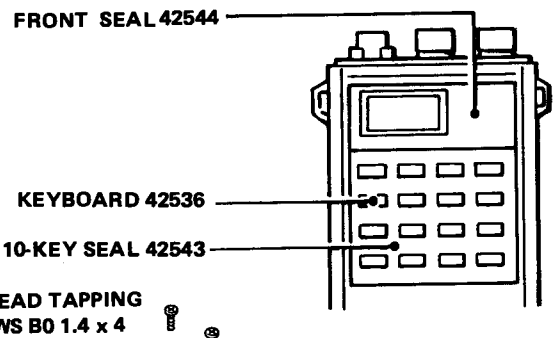

5-7 BOTTOM UNIT DISASSEMBLY

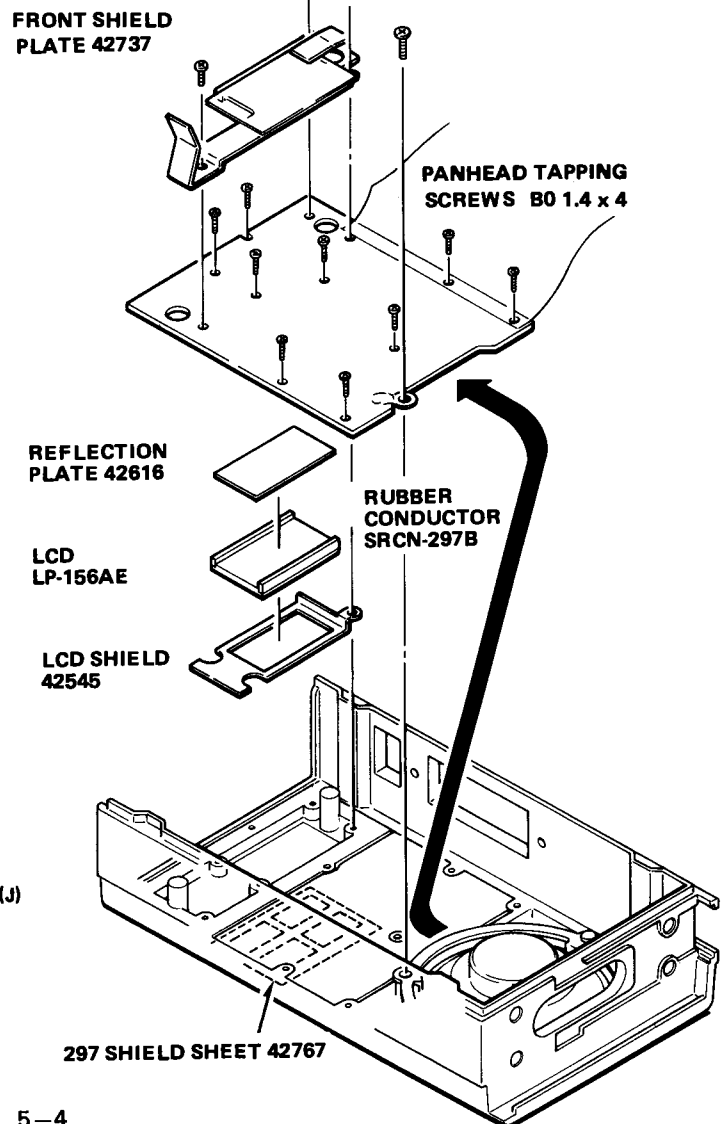
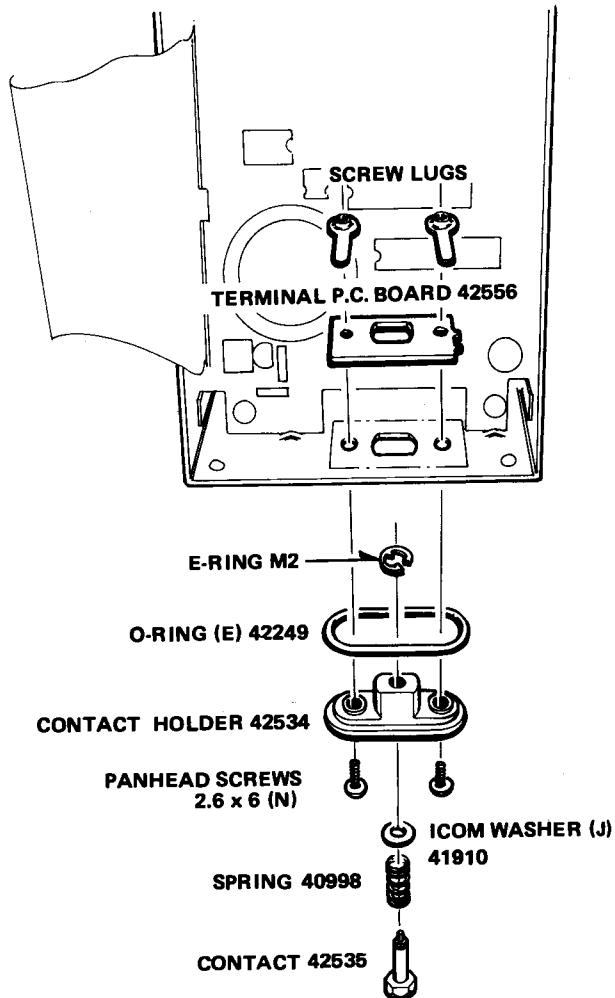

SECTION 6 MAINTENANCE AND ADJUSTMENT

6-1 MEASURING INSTRUMENTS REQUIRED FOR ADJUSTMENTS

INSTRUMENT	GRADE AND RANGE	
(1) Voltage regulated power supply	Output voltage Capacity	5 ~ 15V DC (Adjustable) 3A or more
(2) RF power meter (Terminated type)	Measuring range Frequency range Impedance SWR	10W 430 ~ 450MHz 50Ω Less than 1:1.2
(3) RF voltmeter	Frequency range Measuring range	0.1 ~ 450MHz 0.001 ~ 10V
(4) AC milli-voltmeter	Measuring range	10mV ~ 10V
(5) Voltmeter	Input impedance	50kΩ DC or better
(6) Ammeter	Measuring range	0 ~ 2A
(7) Distortion meter	Frequency range Measuring range	1kHz ± 10Hz 1% ~ 100%
(8) SINAD meter		
(9) Audio generator	Output frequency Output voltage Distortion	200 ~ 3000Hz 0 ~ 100mV Less than 0.1%
(10) Attenuator	Attenuator input Power attenuation	At least 5W 30dB
(11) Signal generator	Frequency range Output level	0.1MHz ~ 450MHz 0.1μV ~ 3.2mV
(12) Frequency counter	Frequency range Accuracy Sensitivity	0.1 ~ 450MHz Better than ± 1ppm 100mV or better
(13) External speaker	Impedance	8Ω
(14) FM deviation meter	Frequency range Measuring range	430 ~ 450MHz 0 ~ ± 10kHz

6-2 CHECK THE FUNDAMENTAL VOLTAGES

TEST INSTRUMENTS REQUIRED			
(1) VOLTAGE REGULATED POWER SUPPLY (2) RF POWER METER (5) VOLTMETER			
CHECK	CONDITION	LOCATION	VALVE
DCPOWER SUPPLY (A)	1 Turn the POWER SWITCH ON.	Connect the minus clip of voltmeter to GND Other end to (A) (B) (E)	13.8V 5V 5V
	(B) 2 Push the PTT SWITCH.	(C) (D)	5V 5V
RECONDITION	Addition check	Failure point	See figure

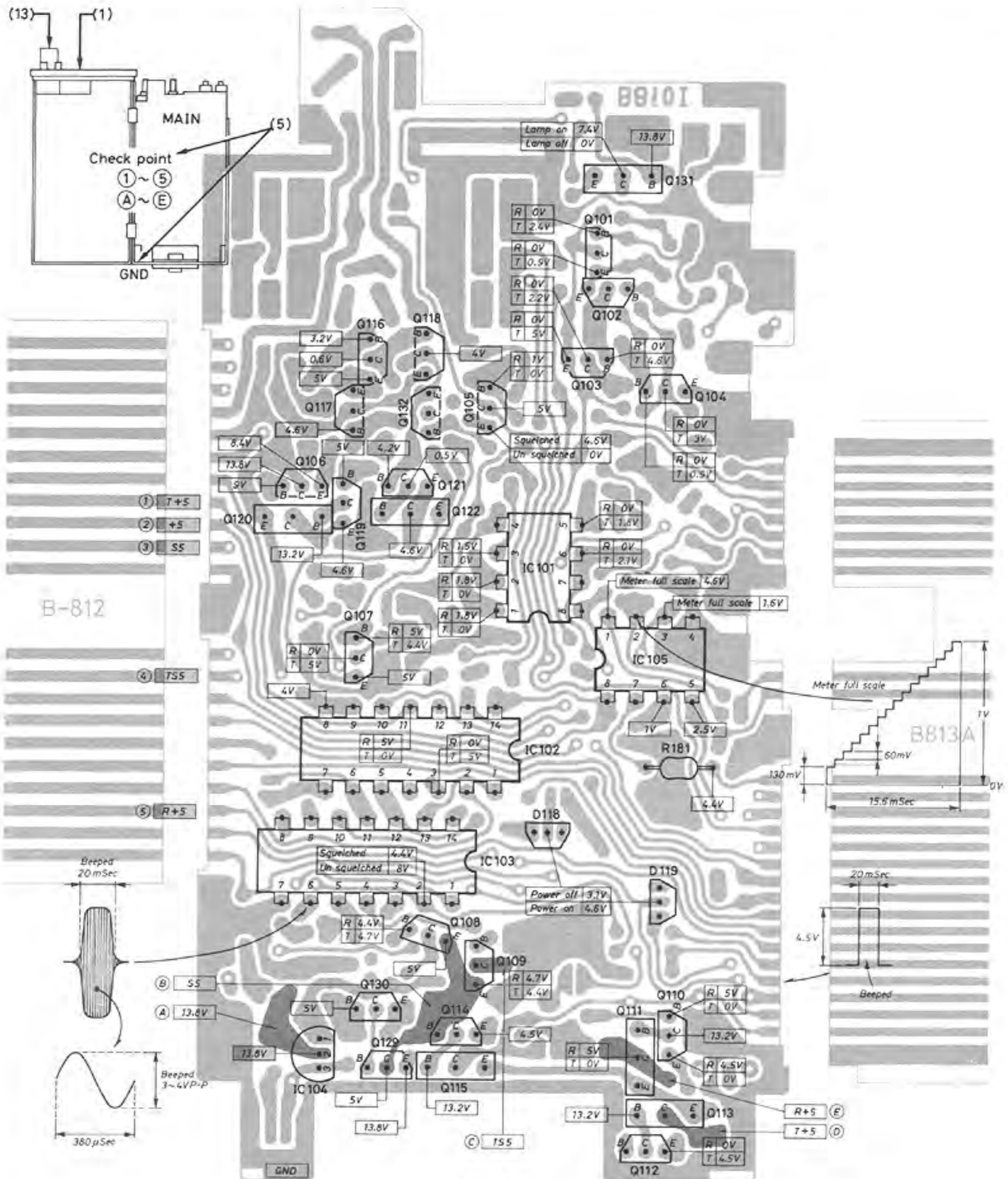

6-3 PLL ADJUSTMENT

TEST INSTRUMENTS REQUIRED							
(1) VOLTAGE REGULATED POWER SUPPLY (2) RF POWER METER (TERMINATED TYPE)				(5) VOLTMETER (12) FREQUENCY COUNTER			
ADJUSTMENT		ADJUSTMENT CONDITIONS	MEASUREMENT		VALUE	ADJUSTMENT POINT	
			UNIT	LOCATION		UNIT	ADJUST
LOCK VOLTAGE (C)	1	• Operating frequency: 430.000MHz 440.000MHz (#05) • Transm it mode	PLL	Connect the voltmeter to R250.	Less than 1.5V	VCO	C702
	2	• Transmit mode • Simplex mode					C705
	3	• Operating frequency: 439.990MHz 449.990MHz (#05) • Receive mode					Verify
REFERENCE FREQUENCY (D)	1	• Operating frequency: 430.000MHz 440.000MHz (#05) • Simplex mode • Receive mode	PLL	Connect the frequency counter to cathode of D208.	408.2MHz	PLL	C298
	2	• RF OUTPUT POWER SELECTOR SWITCH: LOW • Transmit mode					Verify

6-4 RECEIVER ADJUSTMENT

TEST INSTRUMENTS REQUIRED							
(1) VOLTAGE REGULATED POWER SUPPLY (3) RF VOLTMETER (4) AC MILLI-VOLTMETER (7) DISTORTION METER				(8) SINAD METER (11) SIGNAL GENERATOR (12) FREQUENCY COUNTER			
ADJUSTMENT		ADJUSTMENT CONDITIONS	MEASUREMENT		VALUE	ADJUSTMENT POINT	
			UNIT	LOCATION		UNIT	ADJUST
LO OUTPUT (E)	1	• Operating frequency: 435.000MHz 445.000MHz (#05) • Receive mode	PLL	Connect the RF voltmeter to cathode of D208.	More than 450mV		Verify
2nd LO FREQUENCY (F)	1	• Operating frequency: 435.000MHz 445.000MHz (#05) • Receive mode	PLL	Loosely couple the frequency counter to X201.	21.345MHz ±750Hz 22.695MHz (#05)		Verify
SENSITIVITY (G)	1	• Operating frequency: 435.000MHz 445.000MHz (#05) • Receive mode • SQUELCH CONTROL: Max. counterclockwise • Apply an RF signal to ANTENNA CONNECTOR. Level: 0.4µV Dev. : ±3.5kHz Mod. : 1kHz	TOP PANEL	Connect the SINAD meter to the EXTERNAL SPEAKER JACK with an 8Ω speaker.	Maximum level	PLL	L206~ L208
	2	• Operating frequency: 435.000MHz 445.000MHz (#05)					L206, L207
Note: Repeat steps 1 and 2 several times until the measured value is at maximum.							
AF OUTPUT (H)	1	• Operating frequency: 435.000MHz 445.000MHz (#05) • Receive mode • Apply an RF signal to the ANTENNA CONNECTOR. Level: 10µV Dev. : ±3.5kHz Mod. : 1kHz	TOP PANEL	Connect the AC milli-voltmeter and distortion meter to the EXTERNAL SPEAKER JACK with an 8Ω speaker.	More than 2.0V rms at 10% distortion.		Verify
S/RF INDICATOR (I)	1	• Operating frequency: 435.000MHz 445.000MHz (#05) • Receive mode • Apply an RF signal to the ANTENNA CONNECTOR Level: 2.5µV	FRONT PANEL	S/RF INDICATOR.	8 dots	PLL	R221
TIGHT SQUELCH SENSITIVITY (J)	1	• Operating frequency: 435.000MHz 445.000MHz (#05) • Receive mode • Apply an RF signal to the ANTENNA CONNECTOR. Level: 0.4µV Dev. : ±3.5kHz Mod. : 1kHz	TOP PANEL	Connect the 8Ω speaker to the EXTERNAL SPEAKER JACK.	Squelch opens.		Verify

PLL UNIT (Bottom view)

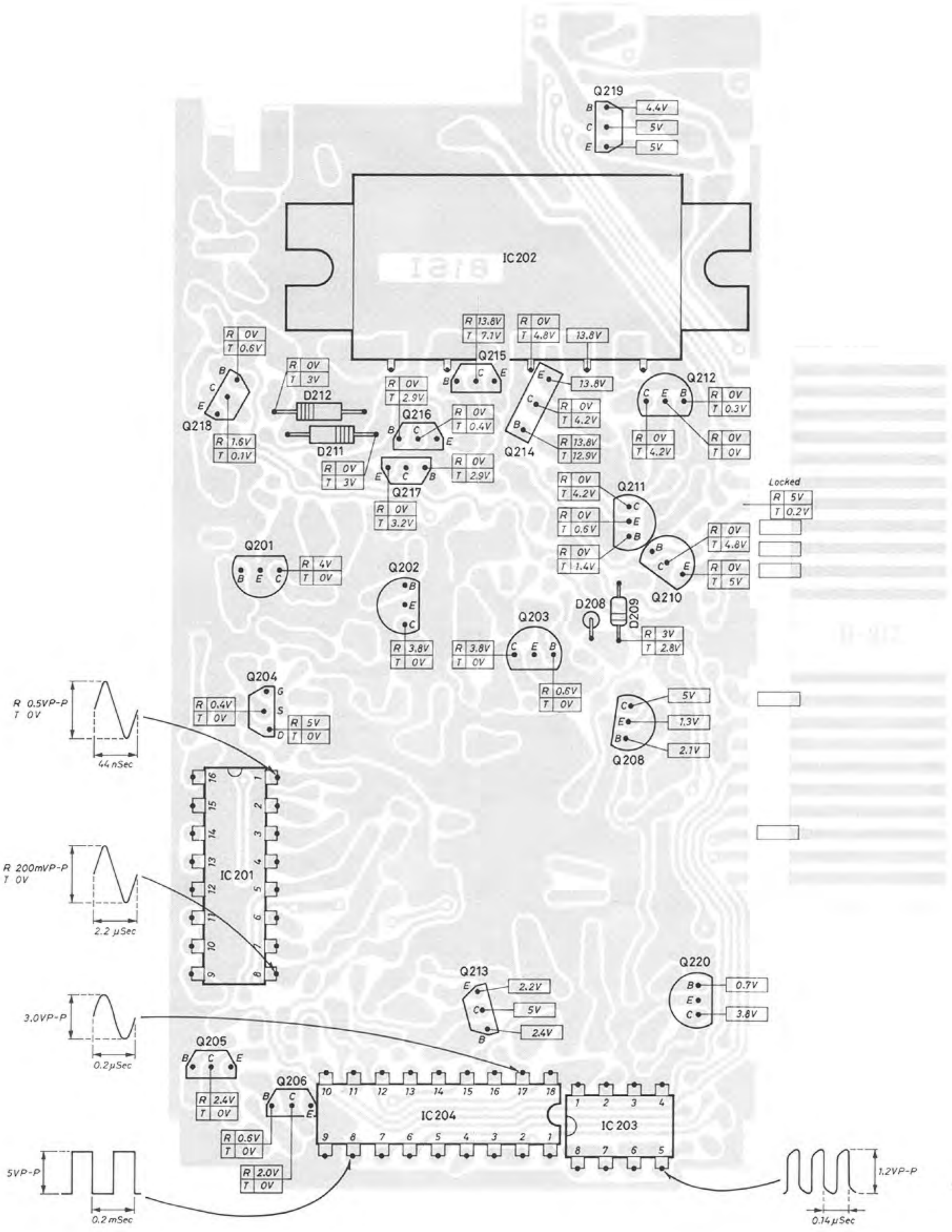

6-5 TRANSMITTER ADJUSTMENT

TEST INSTRUMENTS REQUIRED							
(1) VOLTAGE REGULATED POWER SUPPLY (2) RF POWER METER (TERMINATED TYPE) (4) AC MILLI-VOLTMETER (6) AMMETER				(9) AUDIO GENERATOR (10) ATTENUATOR (14) FM DEVIATION METER			
ADJUSTMENT		ADJUSTMENT CONDITIONS	MEASUREMENT		VALUE	ADJUSTMENT POINT	
			UNIT	LOCATION		UNIT	ADJUST
OUTPUT POWER (K)	1	<ul style="list-style-type: none"> Operating frequency: 435.000MHz 445.000MHz (#05) RF OUTPUT POWER SELECTOR SWITCH: HIGH Power supply: 13.2V 	TOP PANEL	Connect an RF power meter to the ANTENNA CONNECTOR.	5.0W	PLL	R264
	2	<ul style="list-style-type: none"> Simplex mode Transmit mode 		Ammeter	Less than 1.9A		Verify
	3	<ul style="list-style-type: none"> RF OUTPUT POWER SELECTOR SWITCH: LOW Transmit mode 		Connect an RF power meter to the ANTENNA CONNECTOR.	0.5W Less than 0.7		R267
	4			Ammeter	Less than 700mA		Verify
	5	<ul style="list-style-type: none"> RF OUTPUT POWER SELECTOR SWITCH: HIGH Power supply: 8.4V Transmit mode 		Connect an RF power meter to the ANTENNA CONNECTOR.	More than 2.5W		Verify
S/RF INDICATOR (L)	1	<ul style="list-style-type: none"> Operating frequency: 445.000MHz 435.000MHz (#04) RF OUTPUT POWER SELECTOR SWITCH: HIGH Transmit mode 	FRONT PANEL	S/RF INDICATOR	Full scale		Verify
	2	<ul style="list-style-type: none"> RF OUTPUT POWER SELECTOR SWITCH: LOW Transmit mode 			7 ± 2 dots		Verify
DEVIATION (M)	1	<ul style="list-style-type: none"> Operating frequency: 435.000MHz 445.000MHz (#05) RF OUTPUT POWER SELECTOR SWITCH: HIGH Apply an AF signal to the EXTERNAL MIC JACK Level: 1kHz/70mV 170mV (#05) Transmit mode 	TOP PANEL	Connect an FM deviation meter to the ANTENNA CONNECTOR via an attenuator.	±5kHz	PLL	R226
	2	<ul style="list-style-type: none"> Verify both band edges 			±5kHz ±10%		Verify.

PLL UNIT

PLL UNIT (Component view)

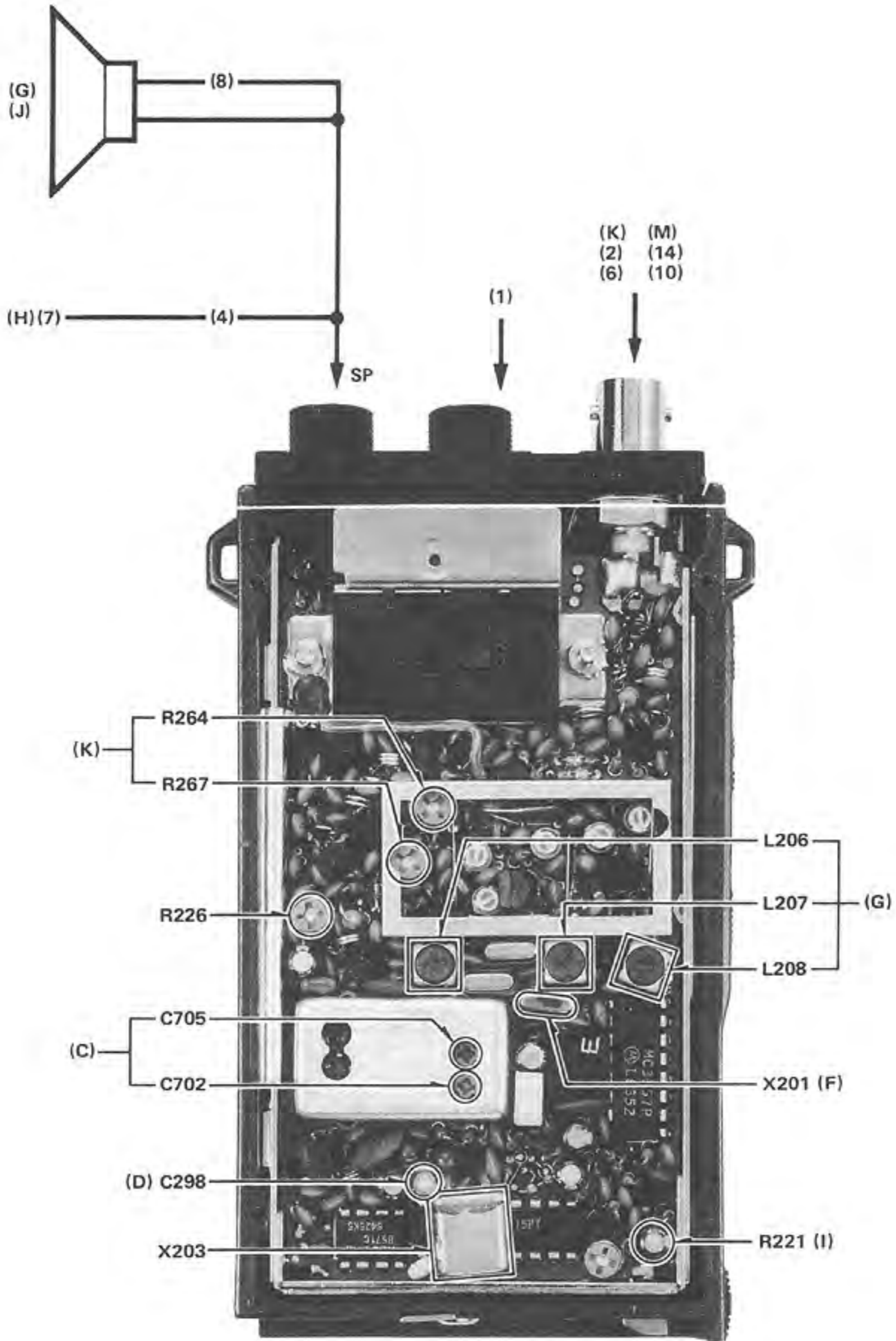

6-6 SUBAUDIBLE TONE, DTMF AND TONE CALL ADJUSTMENT

TEST INSTRUMENTS REQUIRED							
(1) VOLTAGE REGULATED POWER SUPPLY (2) RF POWER METER (TERMINATED TYPE)				(10) ATTENUATOR (14) FM DEVIATION METER			
ADJUSTMENT	ADJUSTMENT CONDITIONS	MEASUREMENT		VALUE	ADJUSTMENT POINT		
		UNIT	LOCATION		UNIT	ADJUST	
SUBAUDIBLE TONE (N)	<ul style="list-style-type: none"> Operating frequency: 435.000MHz 445.000MHz (#05) Simplex mode FM deviation meter: HPF (50Hz): OFF LPF (20Hz): ON Tone number: 01 Transmit mode 	TOP PANEL	Connect an FM deviation meter to the ANTENNA CONNECTOR via an attenuator.	$\pm 0.5\text{kHz}$	TONE	R510	
DTMF (O)	<ul style="list-style-type: none"> Operating frequency: 435.000MHz 445.000MHz (#05) Simplex mode Transmit mode Push and hold [D] key. 	TOP PANEL	Connect an FM deviation meter to the ANTENNA CONNECTOR via an attenuator.	$\pm 3.5\text{kHz}$	TONE	R507	
TONE CALL	<ul style="list-style-type: none"> Operating frequency: 435.000MHz (#4) 445.000MHz (#05) TONE CALL Switch ON 	TON CALL P.C. Board	Bring to near X601	7.168MHz $\pm 0.5\text{kHz}$	TONE CALL	Verity	
		TOP PANEL	Connect an FM deviation meter to the ANTENNA CONNECTOR via an attenuator.	3.5kHz $\pm 10\%$	TONE CALL	R603	

TONE UNIT

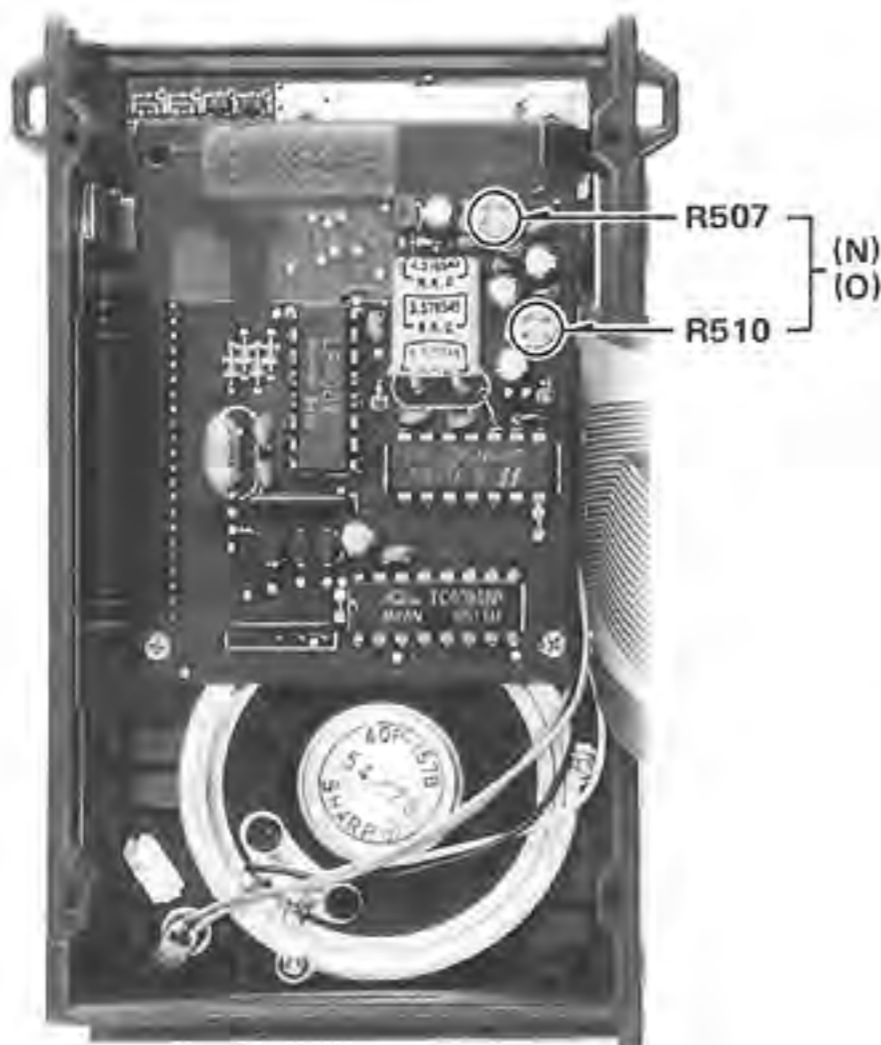

TONE CALL UNIT (#04)



LOGIC UNIT

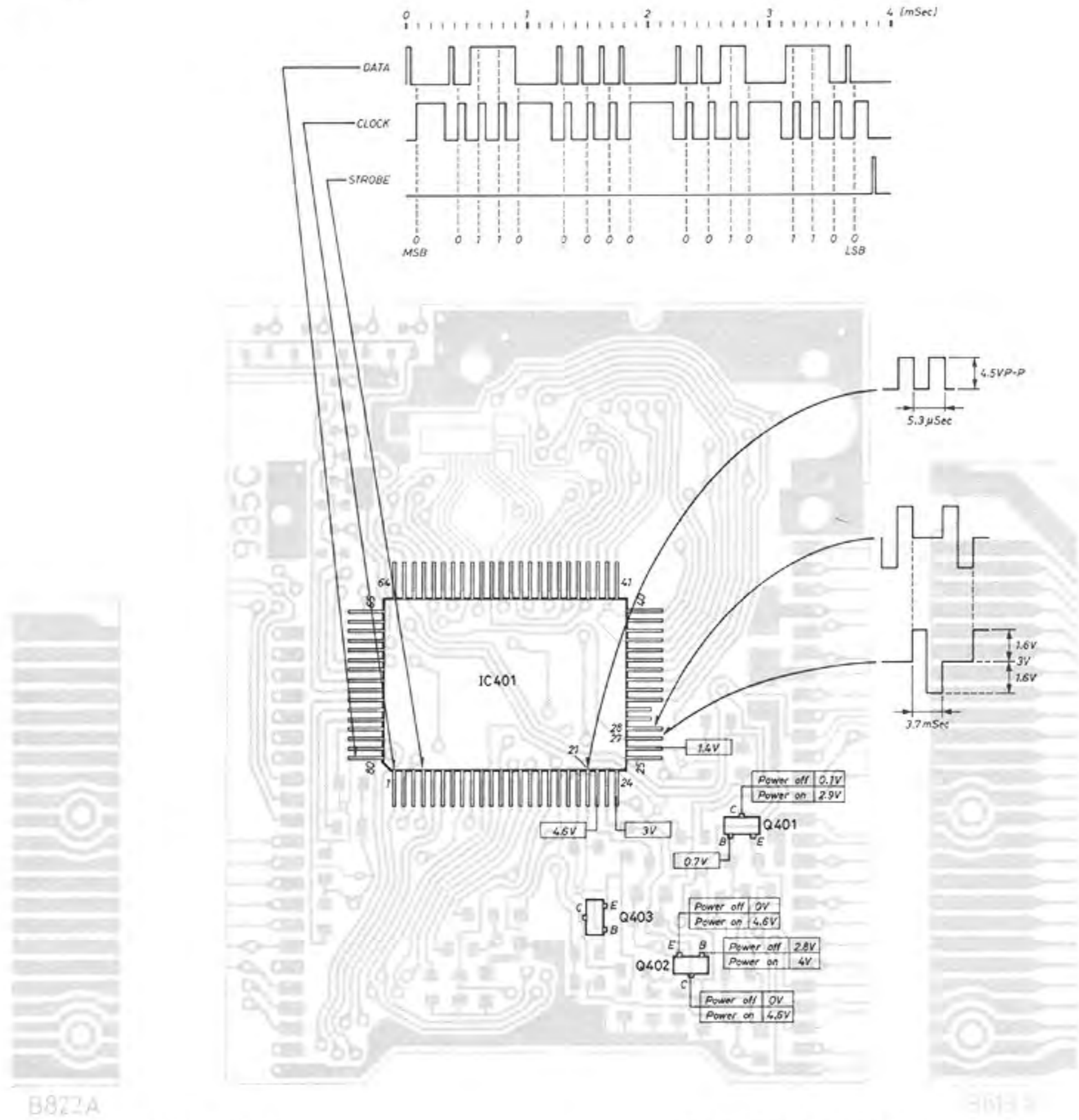

TONE UNIT

TONE CALL UNIT (#04)

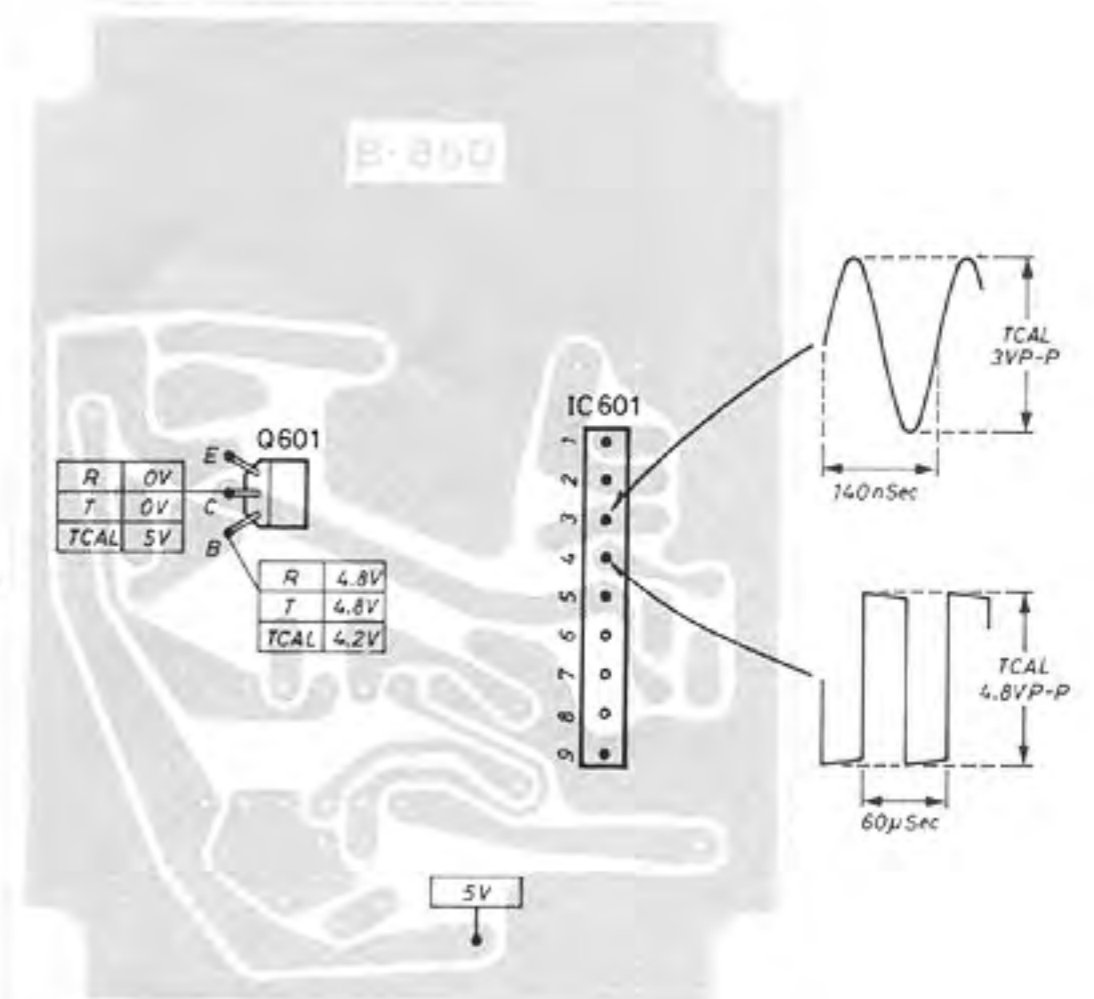
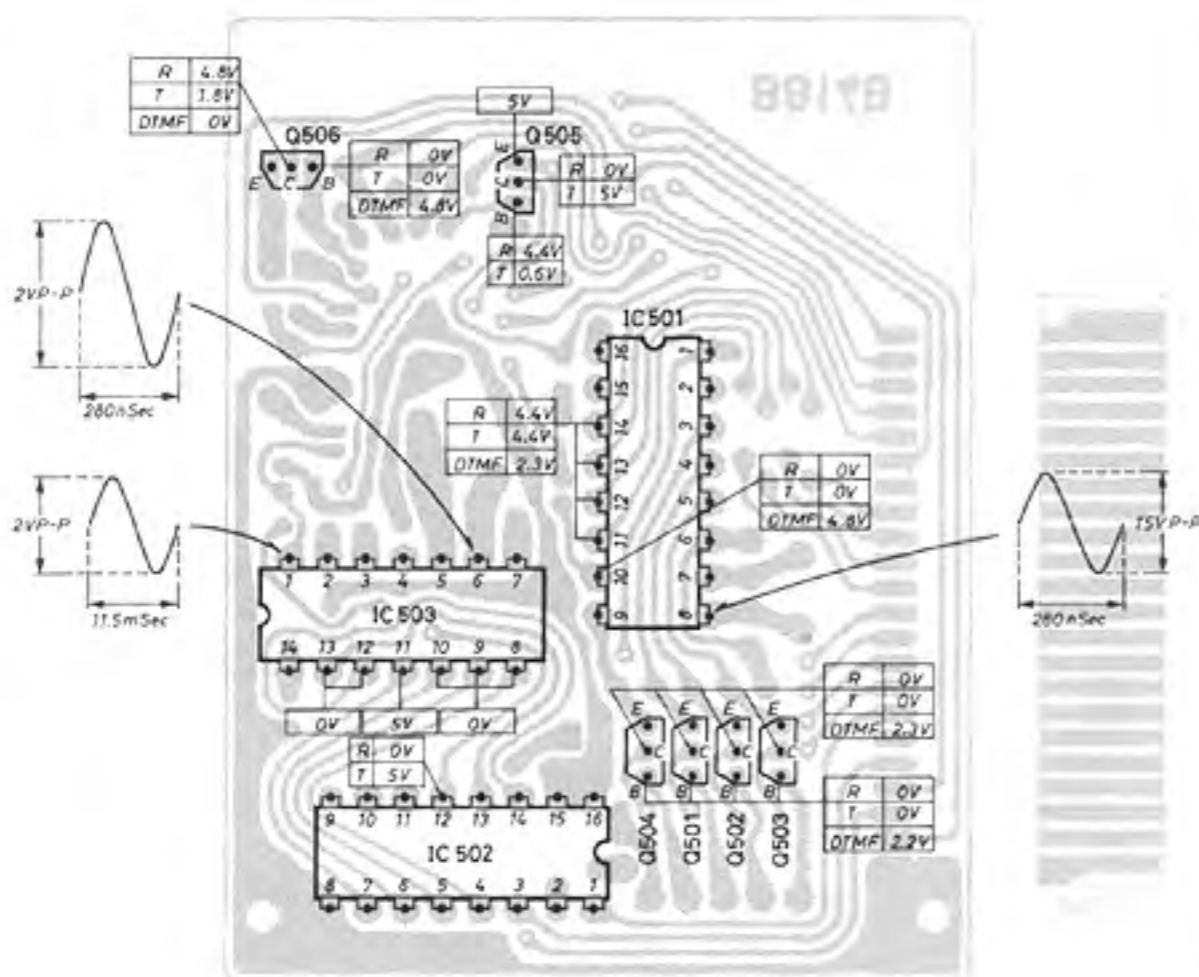

SECTION 7 BOARD LAYOUT

7-1 MAIN UNIT (Bottom view)

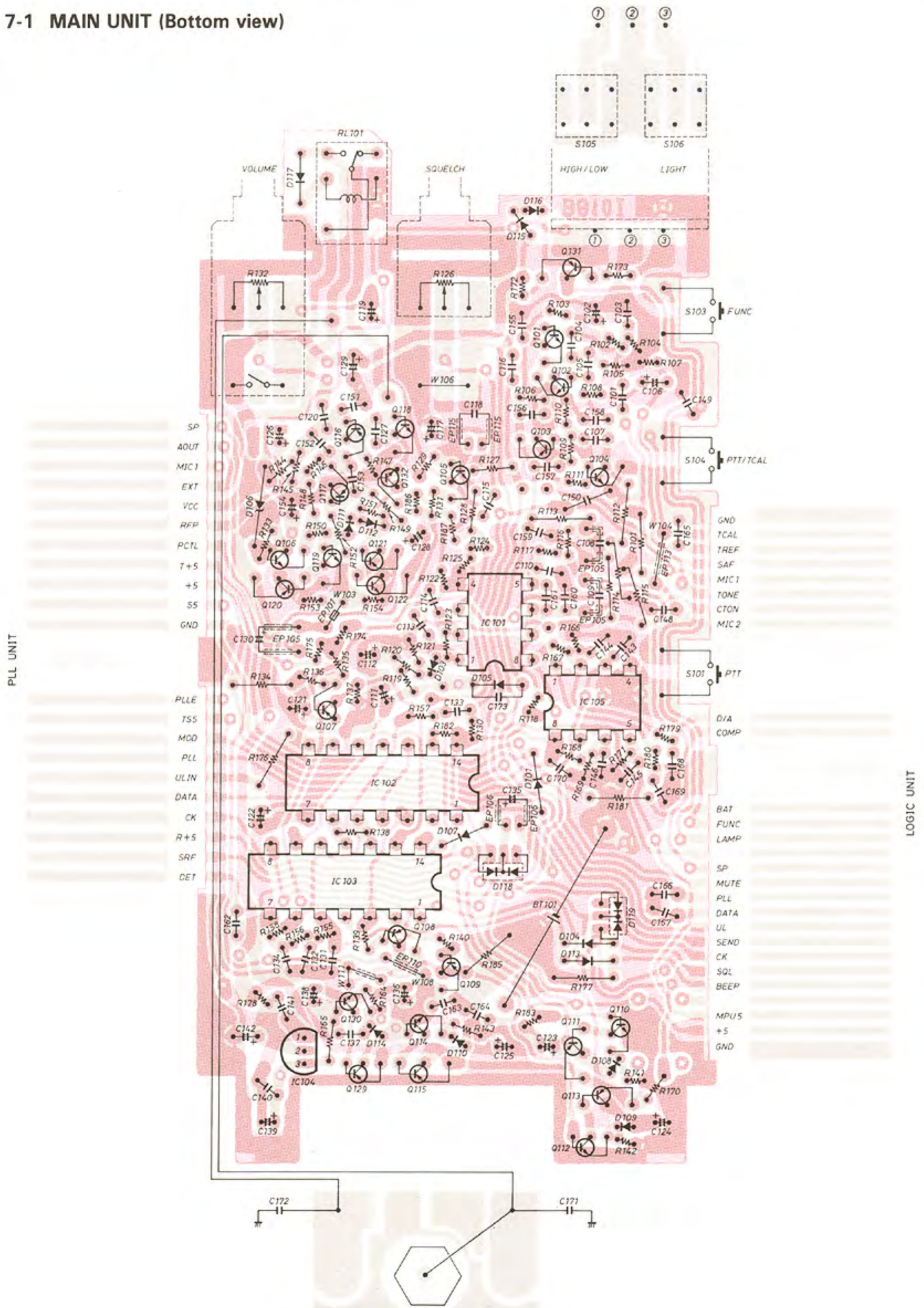

7-3-1 LOGIC UNIT (CONPORNENT SIDE)

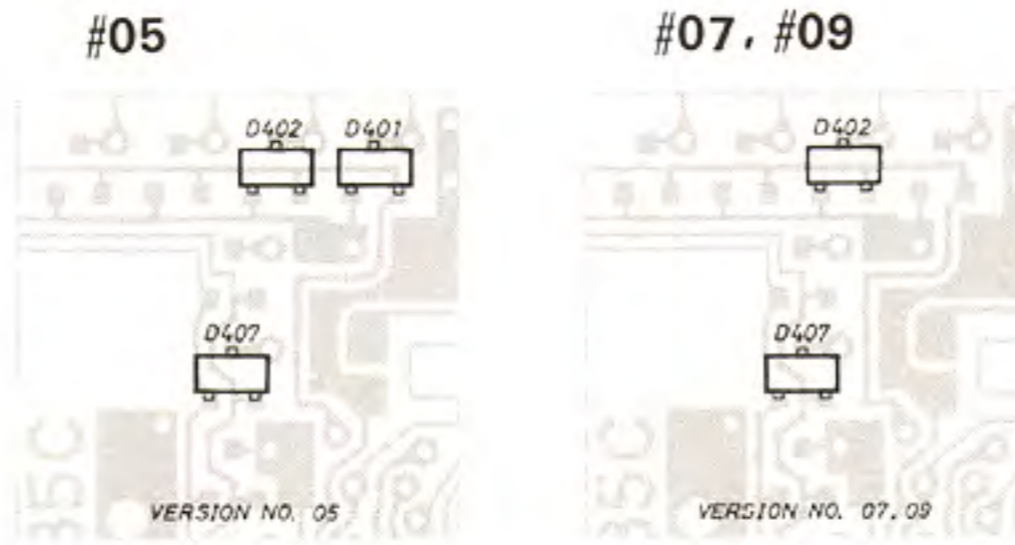

TONE UNIT(VERSION NO. 05, 09)

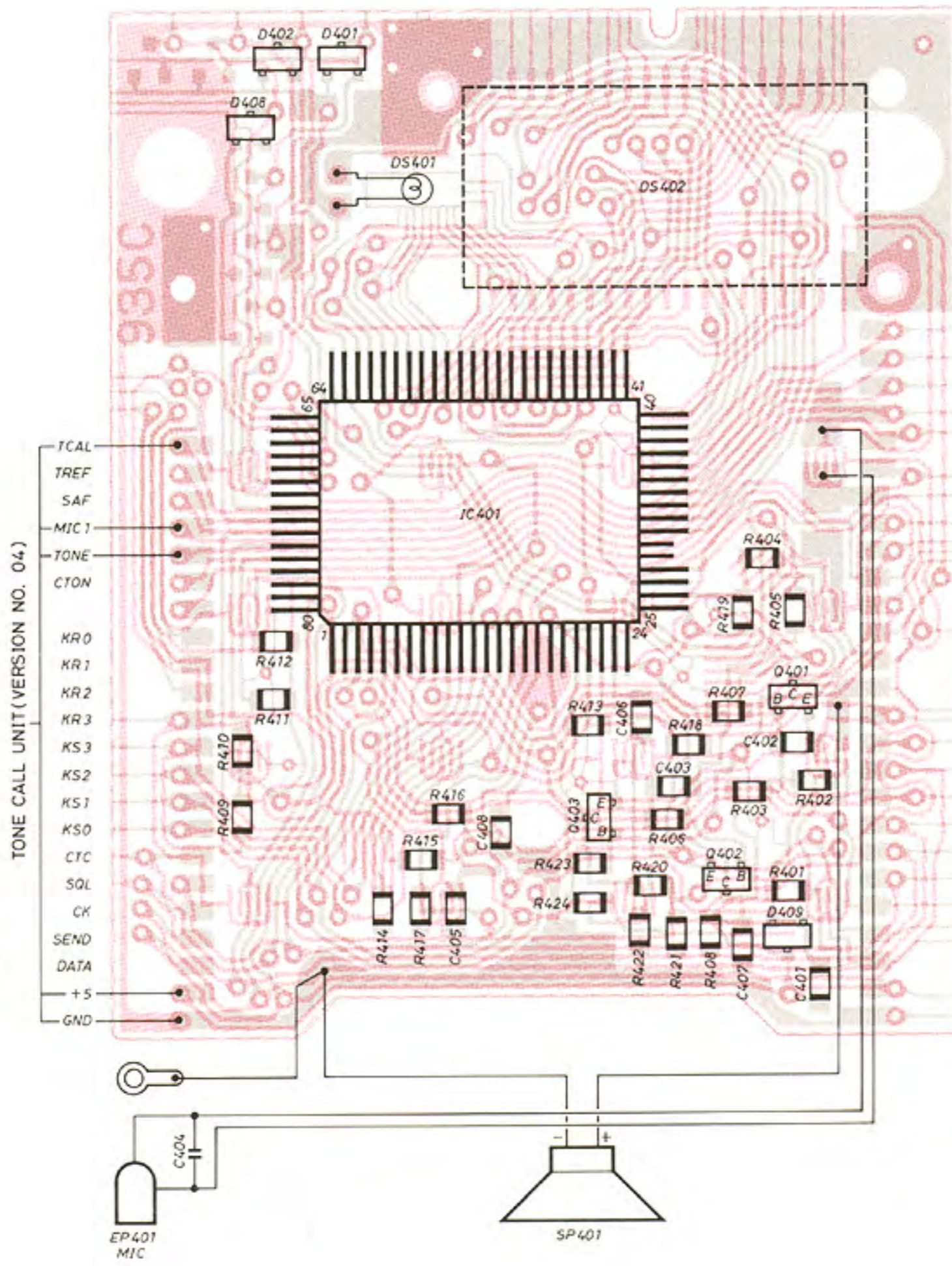

TONE CALL UNIT(VERSION NO. 04)

GND
 TCAL
 TREF
 SAF
 MIC1
 TONE
 CTON
 MIC2
 D/A
 COMP
 BAT
 FUNC
 LAMP
 SPE
 SP
 MUTE
 PLL
 DATA
 UL
 SEND
 CK
 SQL
 BEEP
 RSET
 MPUS
 +5
 GND

MAIN UNIT

SECTION 8 SCHEMATIC DIAGRAM

8-1 MAIN UNIT

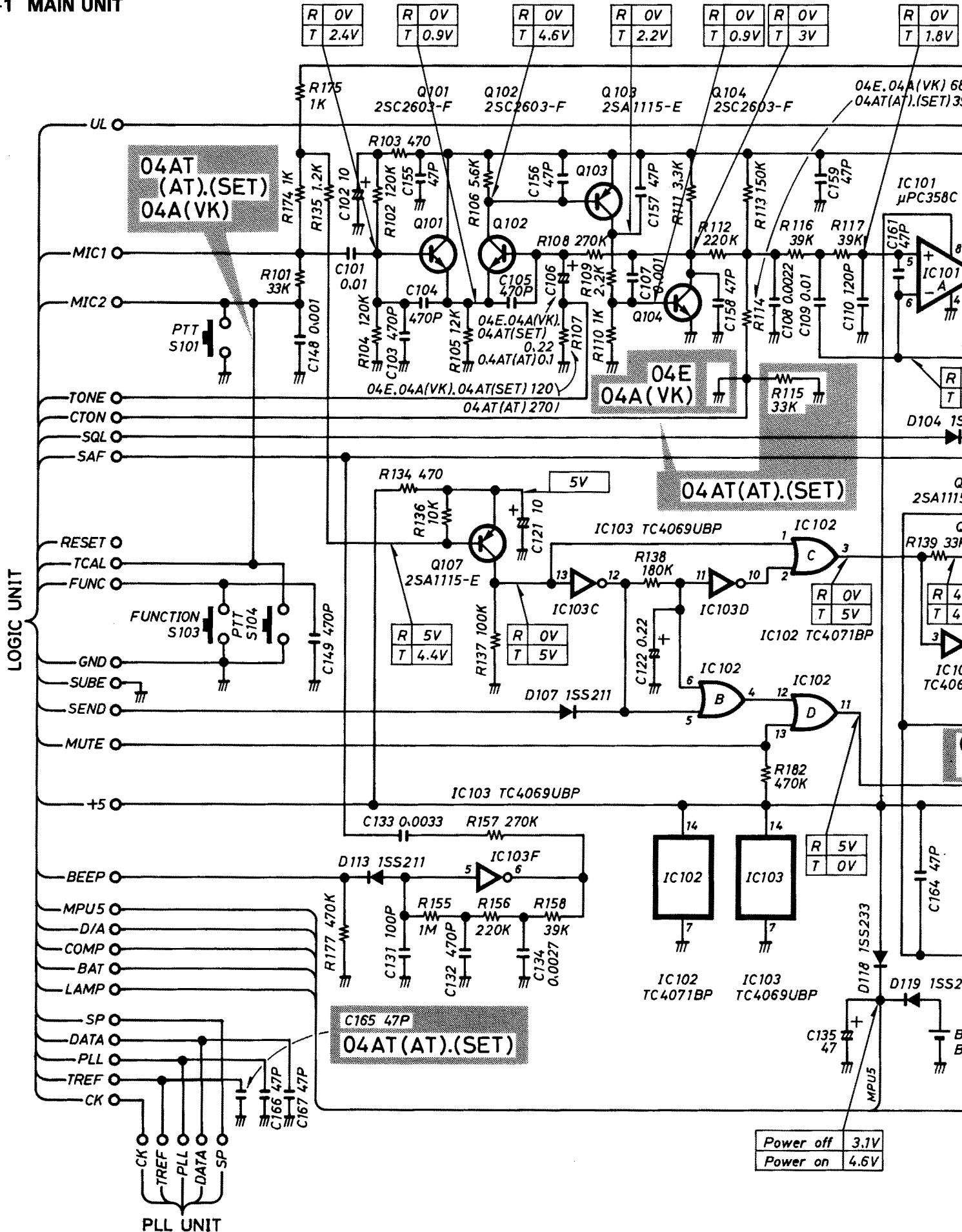

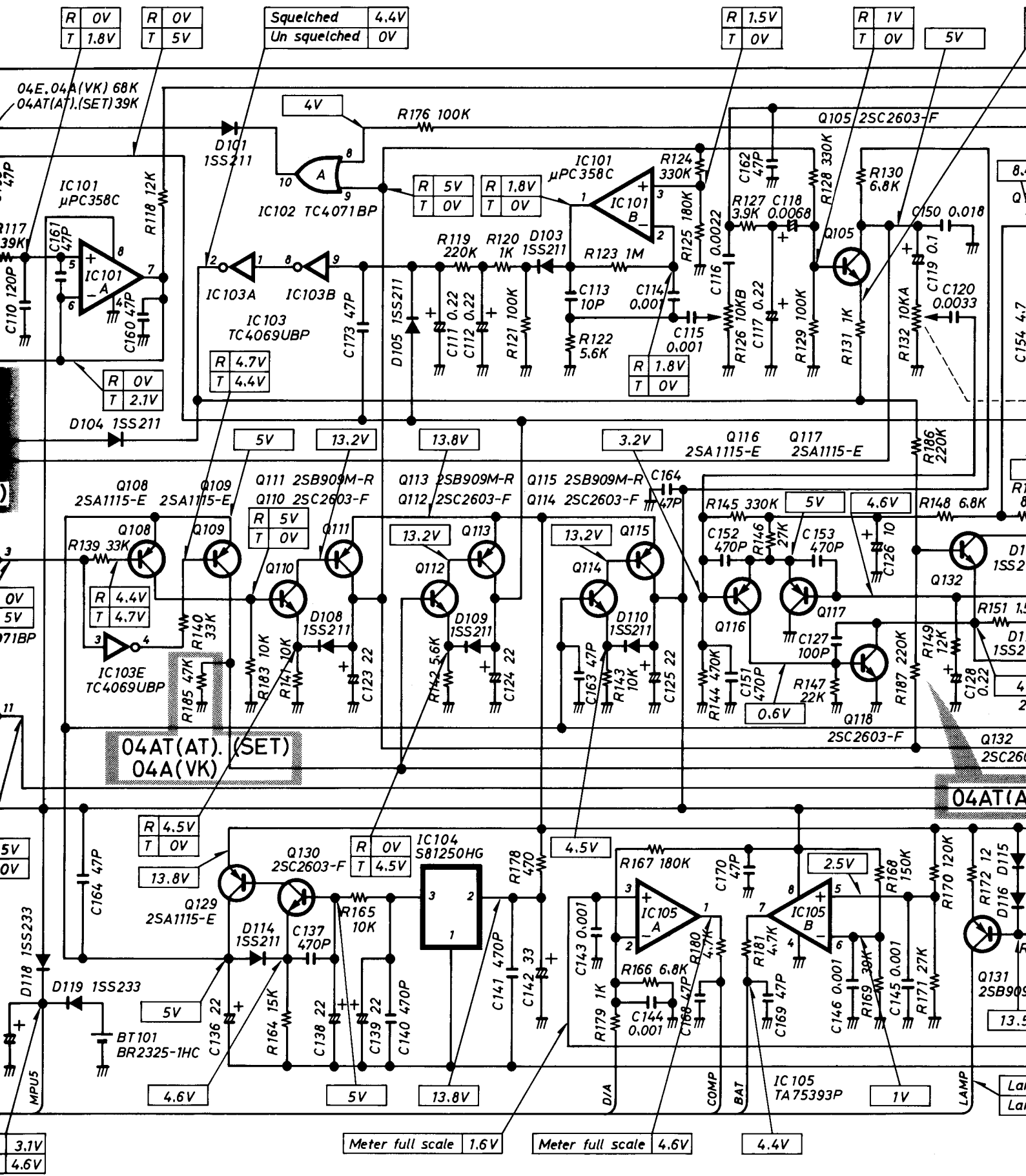

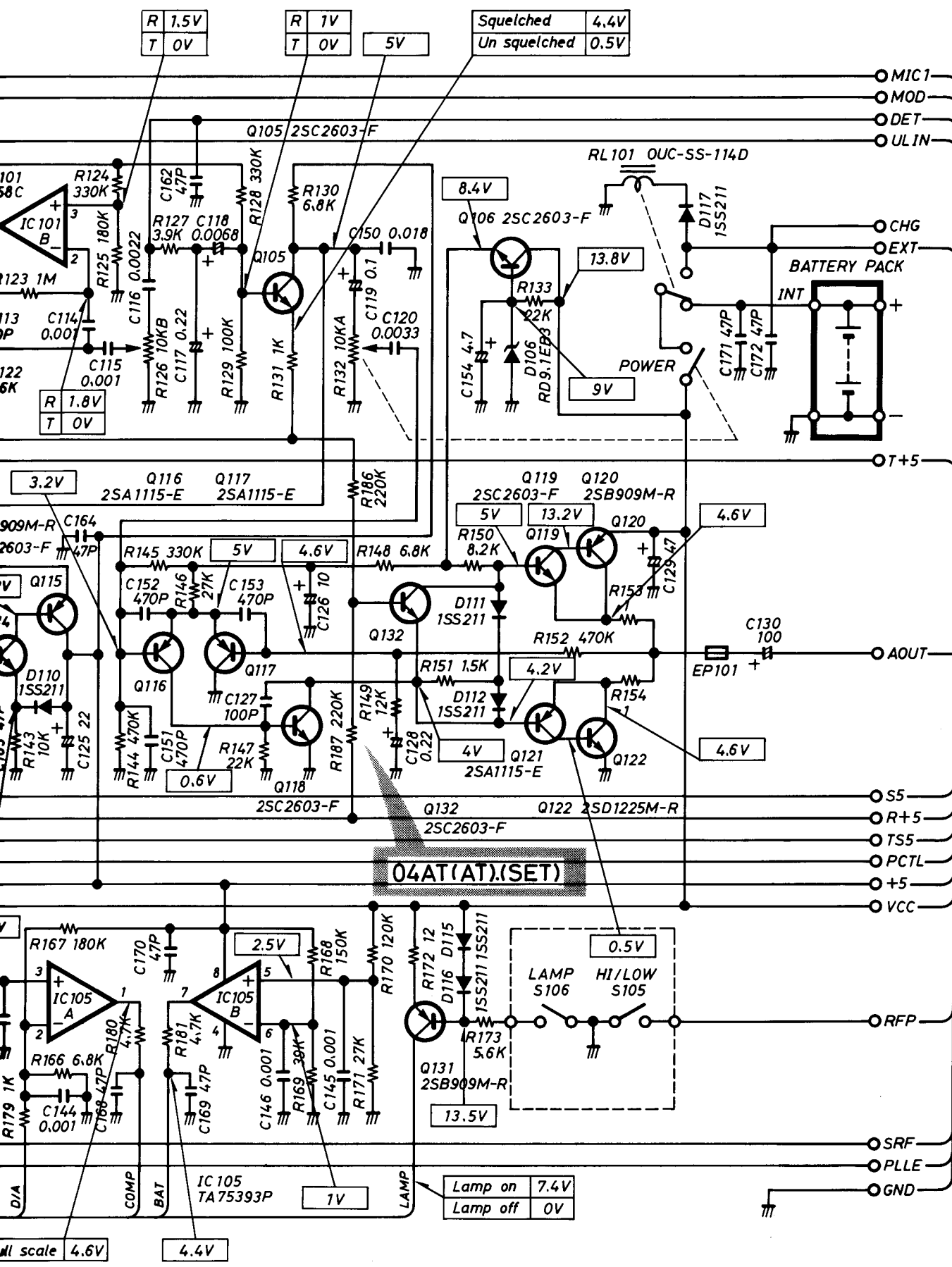

R	1.5V
T	0V

R	1V
T	0V

Squelched	4.4V
Un squelched	0.5V

R	1.8V
T	0V

3.2V

8.4V

13.8V

9V

5V

4.6V

5V

13.2V

4.6V

0.6V

4.2V

4.6V

2.5V

4.6V

4.4V

Lamp on	7.4V
Lamp off	0V

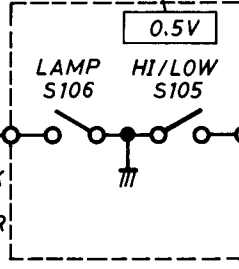

04AT(AT).(SET)

PLL UNIT

8-2 PLL UNIT

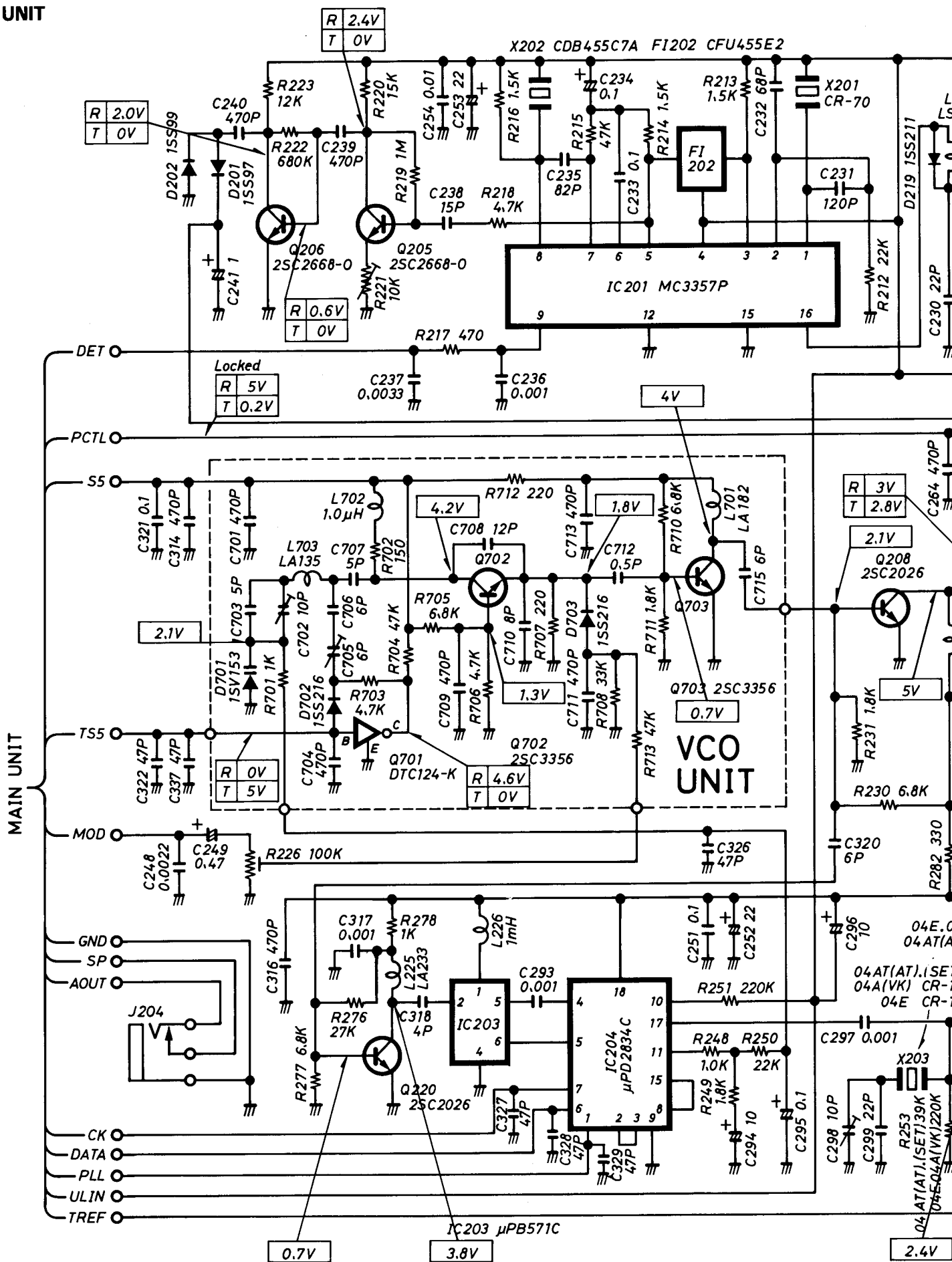

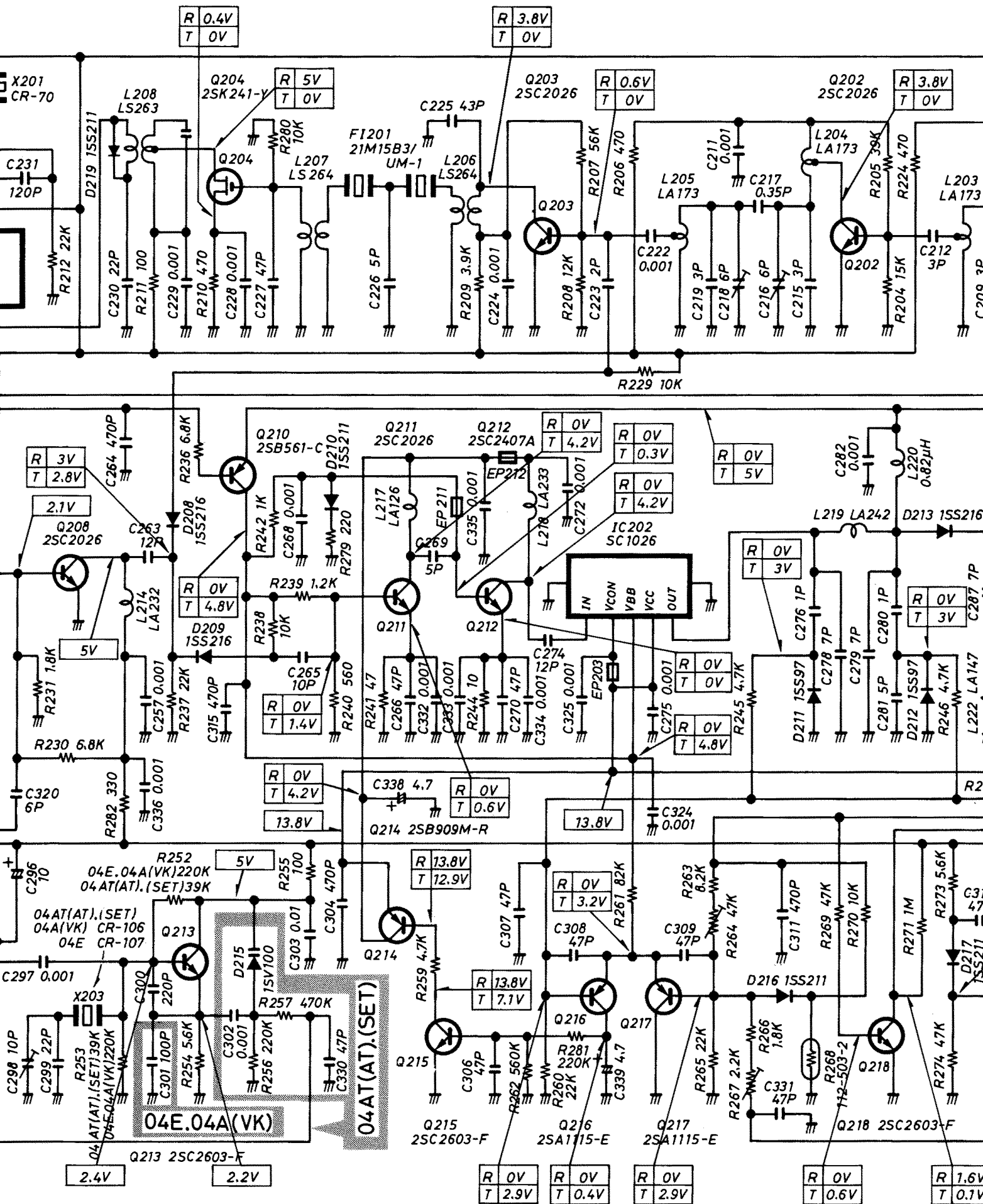

8-3 LOGIC UNIT

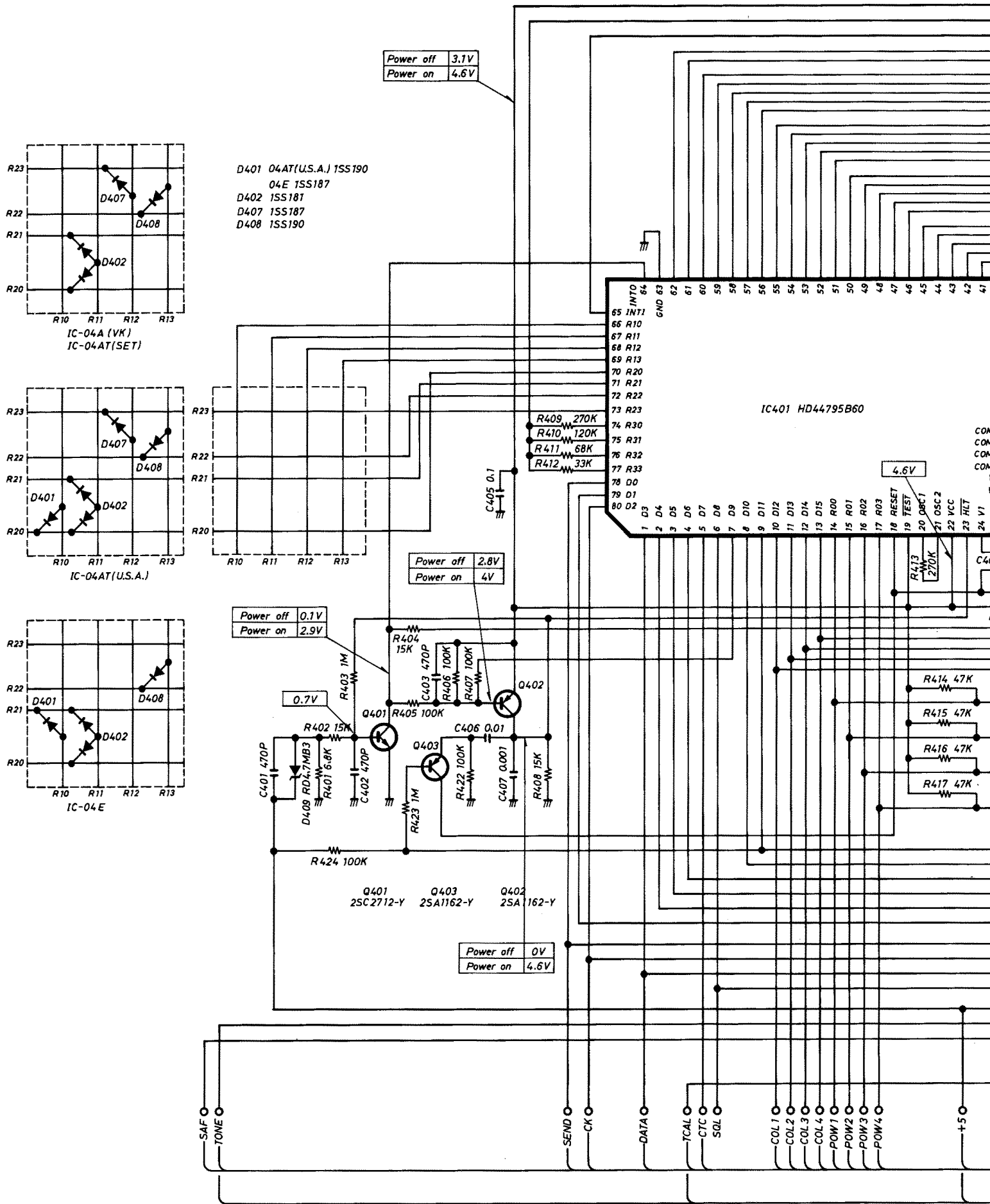

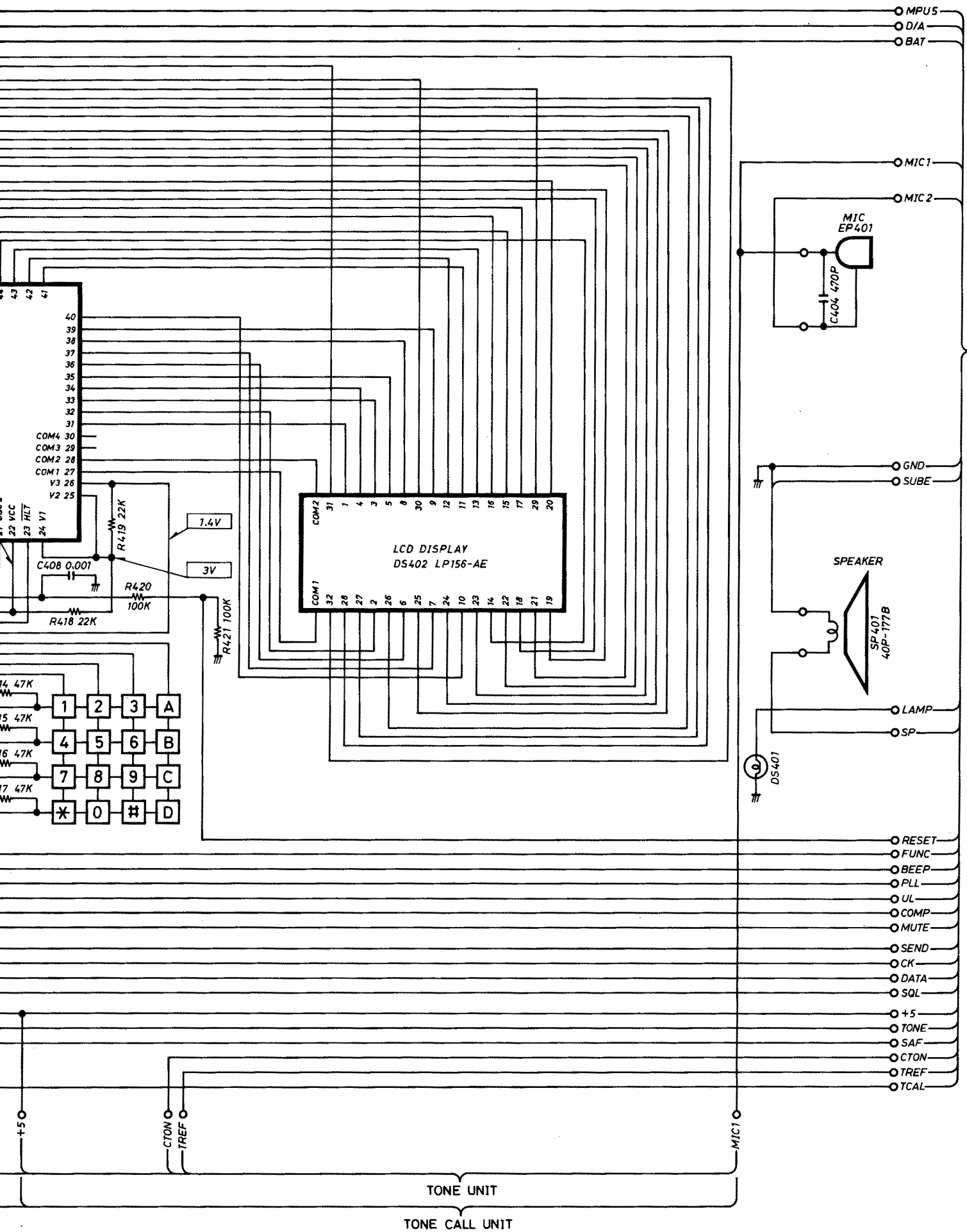

TONE CALL UNIT

8-4 TONE UNIT

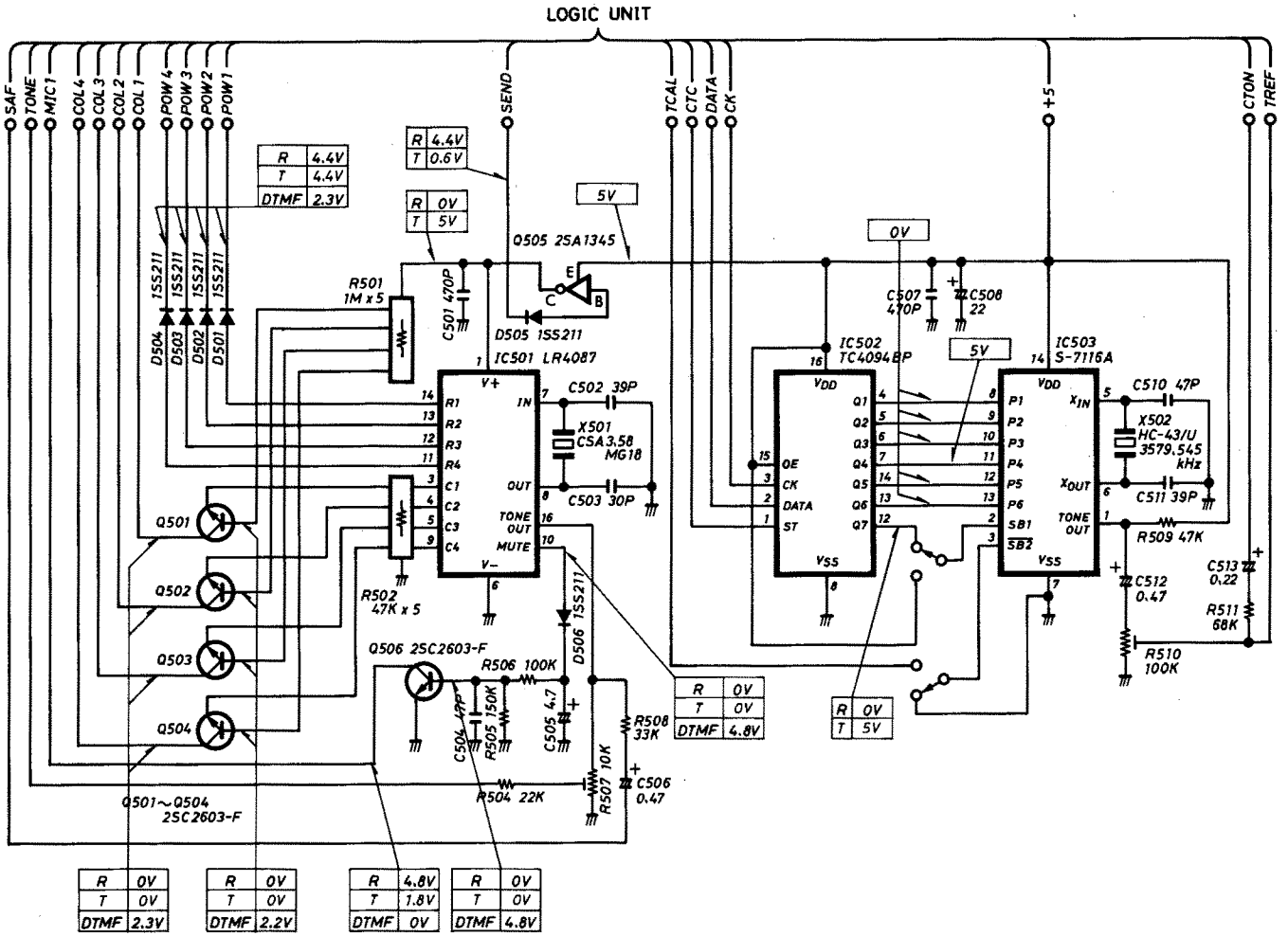

8-5 TONE CALL UNIT

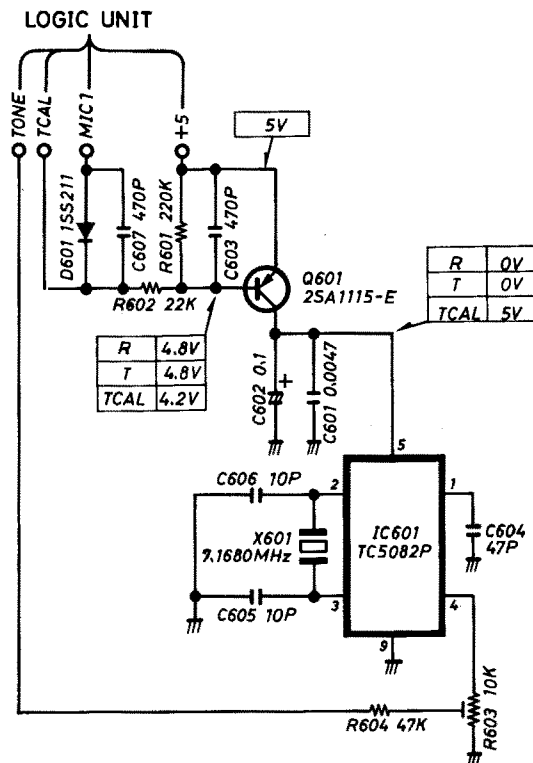

SECTION 9 TROUBLESHOOTING

9-1 NO POWER

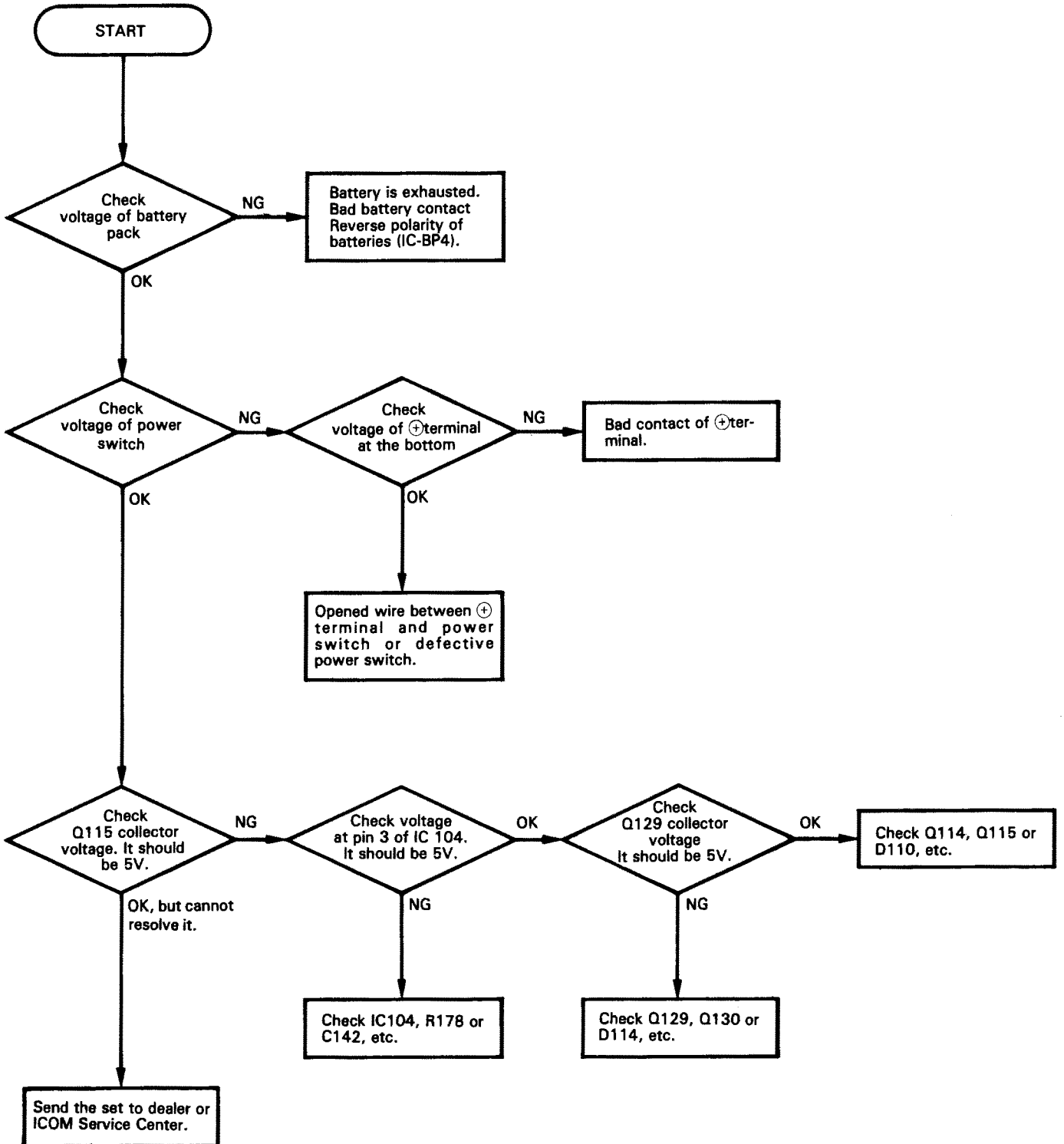

9-2 PLL FAILURE

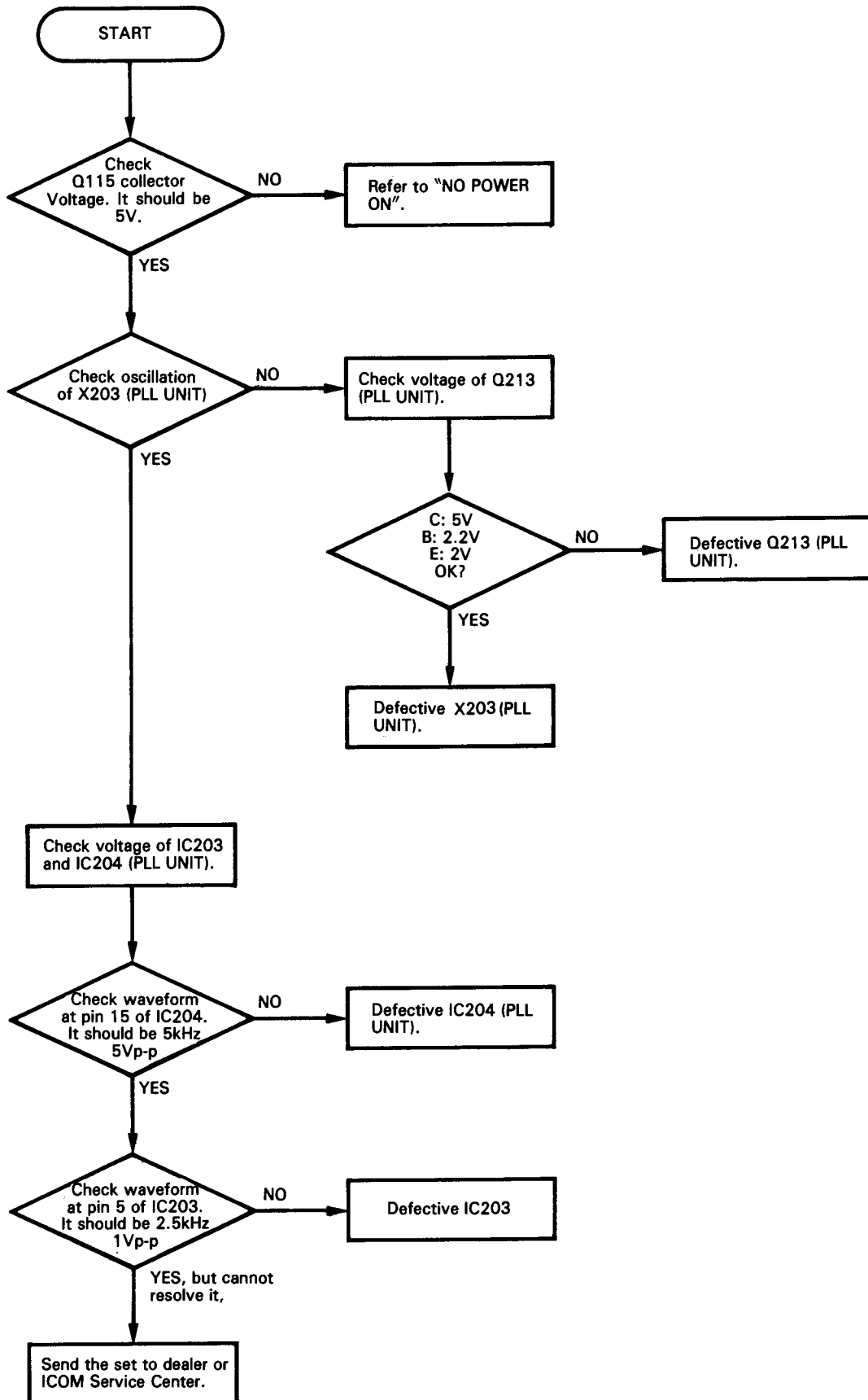

9-3 NO RECEPTION

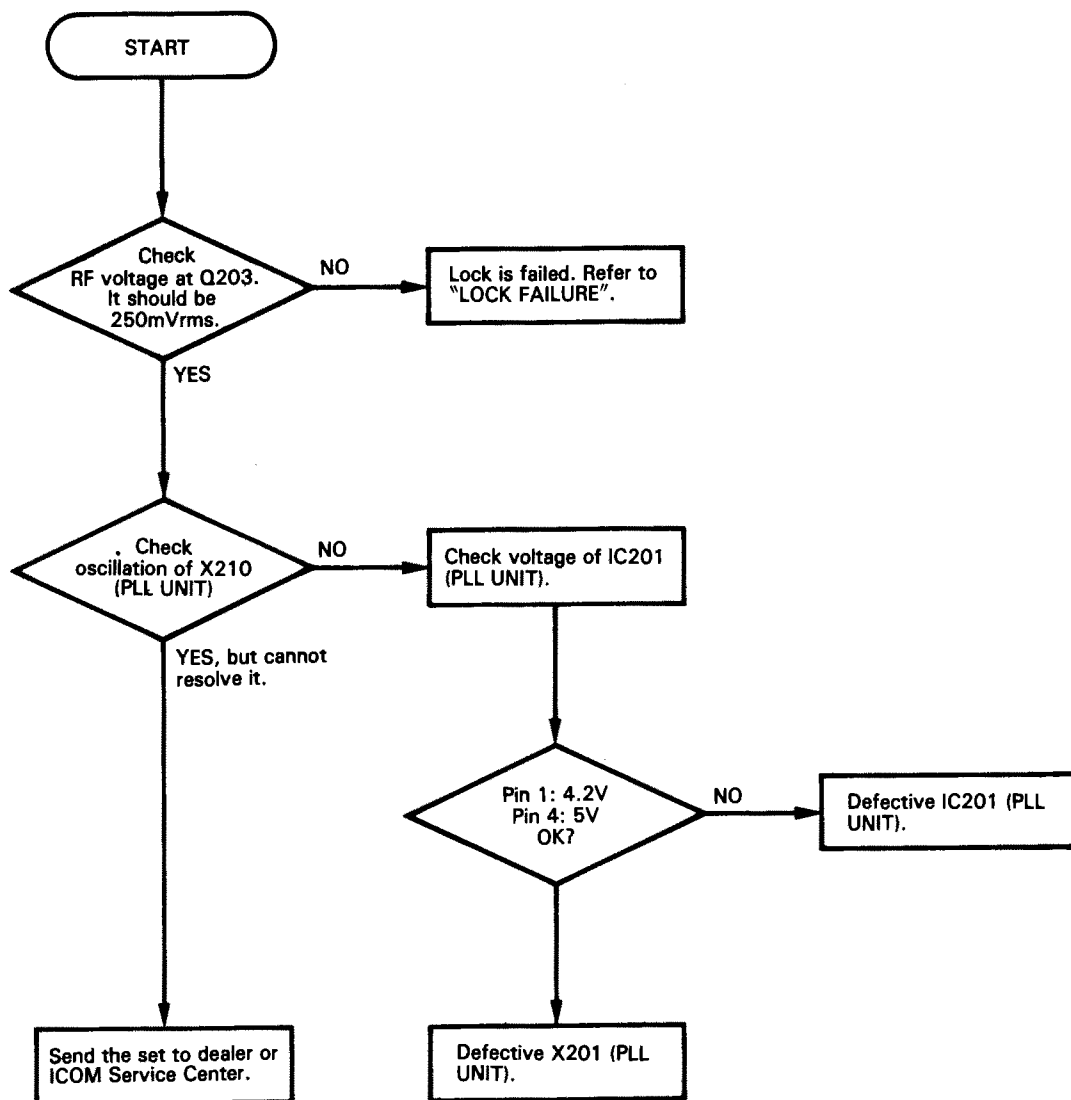

9-4 NO TRANSMIT RF POWER

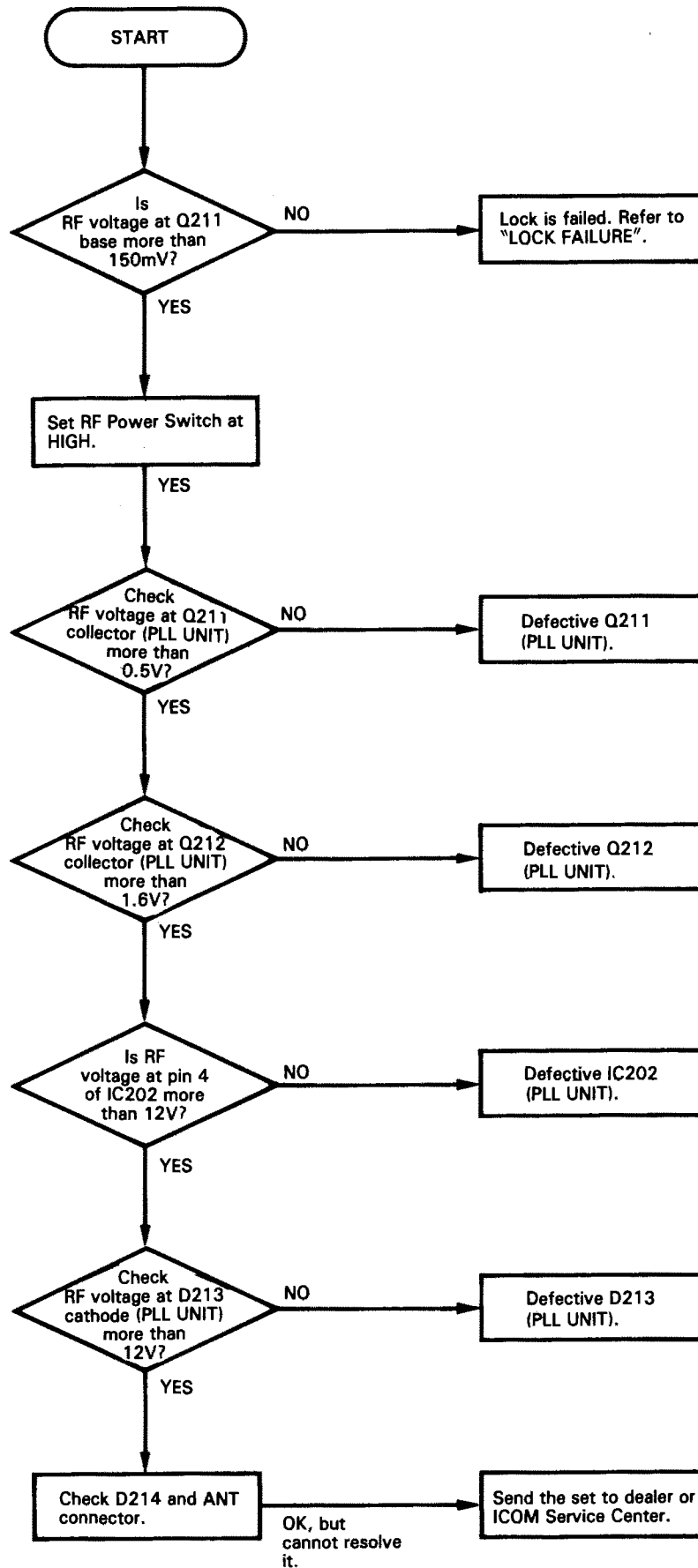

SECTION 10 PARTS LIST

[MAIN] UNIT

REF.NO.	DESCRIPTION	PART NO.
IC101	IC	μPC358C
IC102	IC	TC4071BP
IC103	IC	TC4069UBP
IC104	IC	S81250HG
IC105	IC	TA75393P
Q101	Transistor	2SC2603-F
Q102	Transistor	2SC2603-F
Q103	Transistor	2SA1115-E
Q104	Transistor	2SC2603-F
Q105	Transistor	2SC2603-F
Q106	Transistor	2SC2603-F
Q107	Transistor	2SA1115-E
Q108	Transistor	2SA1115-E
Q109	Transistor	2SA1115-E
Q110	Transistor	2SC2603-F
Q111	Transistor	2SB909M-R
Q112	Transistor	2SC2603-F
Q113	Transistor	2SB909M-R
Q114	Transistor	2SC2603-F
Q115	Transistor	2SB909M-R
Q116	Transistor	2SA1115-E
Q117	Transistor	2SA1115-E
Q118	Transistor	2SC2603-F
Q119	Transistor	2SC2603-F
Q120	Transistor	2SB909M-R
Q121	Transistor	2SA1115-E
Q122	Transistor	2SD1225M-R
Q129	Transistor	2SA1115-E
Q130	Transistor	2SC2603-F
Q131	Transistor	2SB909M-R
Q132	Transistor	2SC2603-F
D101	Diode	1SS211
D103	Diode	1SS211
D104	Diode	1SS211
D105	Diode	1SS211
D106	Zener	RD9.1EB3
D107	Diode	1SS211
D108	Diode	1SS211
D109	Diode	1SS211
D110	Diode	1SS211
D111	Diode	1SS211
D112	Diode	1SS211
D113	Diode	1SS211
D114	Diode	1SS211
D115	Diode	1SS211
D116	Diode	1SS211
D117	Diode	1SS211
D118	Diode	1SS233
D119	Diode	1SS233
R101	Resistor	33k R10
R102	Resistor	120k ELR10
R103	Resistor	470 ELR10
R104	Resistor	120k ELR10
R105	Resistor	12k ELR10

[MAIN] UNIT

REF.NO.	DESCRIPTION	PART NO.
R106	Resistor	5.6k ELR10
R107	Resistor	120 ELR10
		(#04,#07,#09 only)
		270 ELR10
		(#05 only)
R118	Resistor	270k ELR10
R119	Resistor	2.2k ELR10
R110	Resistor	1k ELR10
R111	Resistor	3.3k ELR10
R112	Resistor	220k ELR10
R113	Resistor	150k R10
R114	Resistor	68k R10
		(#04,#07 only)
		39k R10
		(#05, #09 only)
R115	Resistor	33k R10
		(#05, #09 only)
R116	Resistor	39k ELR10
R117	Resistor	39k ELR10
R108	Resistor	12k ELR10
R109	Resistor	220k ELR10
R120	Resistor	1k ELR10
R121	Resistor	100k ELR10
R122	Resistor	5.6k ELR10
R123	Resistor	1M ELR10
R124	Resistor	330k ELR10
R125	Resistor	180k ELR10
R126	Variable	K09110019-10KB
R127	Resistor	3.9k ELR10
R128	Resistor	300k ELR10
R129	Resistor	100k ELR10
R130	Resistor	6.8k ELR10
R131	Resistor	1k ELR10
R132	Variable	K0911100A-5R1111-10KA
R133	Resistor	22k ELR10
R134	Resistor	470 R10
R135	Resistor	1.2k ELR10
R136	Resistor	10k ELR10
R137	Resistor	100k ELR10
R138	Resistor	180k ELR10
R139	Resistor	33k ELR10
R140	Resistor	33k ELR10
R141	Resistor	10k ELR10
R142	Resistor	5.6k ELR10
R143	Resistor	10k ELR10
R144	Resistor	470k ELR10
R145	Resistor	330k ELR10
R146	Resistor	27k ELR10
R147	Resistor	22k ELR10
R148	Resistor	6.8k ELR10
R149	Resistor	12k ELR10
R150	Resistor	8.2k ELR10
R151	Resistor	1.5k ELR10
R152	Resistor	470k ELR10
R153	Resistor	1 ELR10
R154	Resistor	1 ELR10
R155	Resistor	1M ELR10
R156	Resistor	220k ELR10
R157	Resistor	270k ELR10

Values without units are:

—Ω (Resistor)

—μF (Capacitor)

[MAIN] UNIT

REF.NO.	DESCRIPTION	PART NO.		
R158	Resistor	39k	ELR10	
R164	Resistor	15k	ELR10	
R165	Resistor	10k	ELR10	
R166	Resistor	6.8k	ELR10	
R167	Resistor	180k	ELR10	
R168	Resistor	150k	ELR10	
R169	Resistor	39k	ELR10	
R170	Resistor	120k	ELR10	
R171	Resistor	27k	ELR10	
R172	Resistor	12	ELR10	
R173	Resistor	5.6k	ELR10	
R174	Resistor	1k	ELR10	
R175	Resistor	1k	ELR10	
R176	Resistor	100k	ELR10	
R177	Resistor	470k	ELR10	
R178	Resistor	470	ELR10	
R179	Resistor	1k	ELR10	
R180	Resistor	4.7k	ELR10	
R181	Resistor	4.7k	ELR10	
R182	Resistor	470k	ELR10	
R183	Resistor	10k	ELR10	
R185	Resistor	47k	R10	
		(#05, #07, #09 only)		
R186	Resistor	220k	ELR10	
R187	Resistor	220k	ELR10	
		(#05, #09 only)		
C101	Barrier Layer	0.01	50V	
C102	Electrolytic	10	16V	RC3
C103	Ceramic	470P	50V	
C104	Ceramic	470P	50V	
C105	Ceramic	470P	50V	
C106	Tantalum	CS15E1VR22		
		(#04, #07, #09 only)		
C106	Tantalum	CS15E1VOR1		
		(#05 only)		
C107	Ceramic	0.001	50V	
C108	Mylar	0.0022	50V	
C109	Mylar	0.01	50V	
C110	Ceramic	120P	50V	
C111	Electrolytic	0.22	50V	RC3
C112	Electrolytic	0.22	50V	RC3
C113	Ceramic	10P	50V	
C114	Ceramic	0.001	50V	
C115	Ceramic	0.001	50V	
C116	Barrier Layer	0.0022	25V	
C117	Electrolytic	0.22	50V	RC3
C118	Barrier Layer	0.0068	25V	
C119	Electrolytic	0.1	50V	RC3
C120	Barrier Layer	0.0033	50V	
C121	Electrolytic	10	16V	RC3
C122	Electrolytic	0.22	50V	RC3
C123	Electrolytic	22	6.3V	RC3
C124	Electrolytic	22	6.3V	RC3
C125	Electrolytic	22	6.3V	RC3
C126	Electrolytic	10	16V	RC3
C127	Ceramic	100P	50V	
C128	Electrolytic	0.22	50V	RC3
C129	Electrolytic	47	25V	MS7
C130	Electrolytic	100	10V	MS7
C131	Ceramic	100P	50V	
C132	Ceramic	470P	50V	

[MAIN] UNIT

REF.NO.	DESCRIPTION	PART NO.		
C133	Barrier Layer	0.0033	50V	
C134	Barrier Layer	0.0027	50V	
C135	Electrolytic	47	6.3V	RC3
C136	Electrolytic	22	6.3V	RC3
C137	Ceramic	470P	50V	
C138	Electrolytic	22	6.3V	RC3
C139	Electrolytic	22	6.3V	RC3
C140	Ceramic	470P	50V	
C141	Ceramic	470P	50V	
C142	Electrolytic	33	25V	RC3
C143	Ceramic	0.001	50V	
C144	Ceramic	0.001	50V	
C145	Ceramic	0.001	50V	
C146	Ceramic	0.001	50V	
C148	Ceramic	0.001	50V	
C149	Ceramic	470P	50V	
C150	Barrier Layer	0.018	50V	
C151	Ceramic	470P	50V	
C152	Ceramic	470P	50V	
C153	Ceramic	470P	50V	
C154	Electrolytic	4.7	25	RC3
C155	Ceramic	47P	50V	
C156	Ceramic	47P	50V	
C157	Ceramic	47P	50V	
C158	Ceramic	47P	50V	
C159	Ceramic	47P	50V	
C160	Ceramic	47P	50V	
C161	Ceramic	47P	50V	
C162	Ceramic	47P	50V	
C163	Ceramic	47P	50V	
C164	Ceramic	47P	50V	
C165	Ceramic	47P	50V	
		(#04, #09 only)		
C166	Ceramic	47P	50V	
C167	Ceramic	47P	50V	
C168	Ceramic	47P	50V	
C169	Ceramic	47P	50V	
C170	Ceramic	47P	50V	
C171	Ceramic	47P	50V	
C172	Ceramic	47P	50V	
C173	Ceramic	47P	50V	
RL101	Relay	OUC-SS-114D		
S101	Switch	KHH 10906	PTT	
S103	Switch	KHH 10906	FUNC	
S104	Switch	KHH 10906	PTT	
S105	Switch	SPH 211B	LAMP	
S106	Switch	SPH 211B	HI/LOW	
BT101	Lithium Backup Battery	BR2325-1HC		
EP101	P.C. Board	B-810 I		
EP102	P.C. Board	B-824A		
EP103	F.P.C. Board	B-812		
EP104	Bead Core	DL-20P2.6-3-1.2H		
EP105	Irrax Tube	φ=0.7 l=4mm		
EP106	Irrax Tube	φ=0.7 l=6mm		

Values without units are:

-Ω (Resistor)

-μF (Capacitor)

[MAIN] UNIT

REF.NO.	DESCRIPTION	PART NO.
EP110	Irrax Tube	$\phi=0.7$ $l=6\text{mm}$
EP112	Aluminum Sheet (F)	42356
EP113	Irrax Tube	$\phi=0.7$ $l=4\text{mm}$ (#5, #7, #9 only)
EP114	Irrax Tube	$\phi=0.7$ $l=3\text{mm}$ (#5, #7, #9 only)
EP115	Irrax Tube	$\phi=0.7$ $l=4\text{mm}$
W101	Wire	23/03/135/D21/W01
W102	Wire	23/03/115/D21/W01
W103	Wire	72/99/50/X98/X98
W104	Wire	72/98/50/X98/X98 (#05, #07, #09 only)
W106	Wire	72/99/50/X98/X98 (#05, #09 only)
W107	Wire	23/03/140/W01/W01 (#05, #09 only)
W108	Wire	72/99/50/X98/X98
W110	Wire	31/03/040/W02/W02
W111	Wire	72/98/040/X98/X98

[PLL] UNIT

REF.NO.	DESCRIPTION	PART NO.
IC201	IC	MC3357P
IC202	IC	SC1026
IC203	IC	μ PB571C
IC204	IC	μ PD2834C
Q201	Transistor	2SC2026
Q202	Transistor	2SC2026
Q203	Transistor	2SC2026
Q204	FET	2SK241-Y
Q205	Transistor	2SC2668-0
Q206	Transistor	2SC2668-0
Q208	Transistor	2SC2026
Q210	Transistor	2SB561-C
Q211	Transistor	2SC2026
Q212	Transistor	2SC2407A
Q213	Transistor	2SC2603-F
Q214	Transistor	2SB909M-R
Q215	Transistor	2SC2603-F
Q216	Transistor	2SA1115-E
Q217	Transistor	2SA1115-E
Q218	Transistor	2SC2603-F
Q219	Transistor	2SA1048-GR
Q220	Transistor	2SC2026
D201	Diode	1SS97
D202	Diode	1SS99
D208	Diode	1SS216
D209	Diode	1SS216
D210	Diode	1SS211
D211	Diode	1SS97
D212	Diode	1SS97
D213	Diode	1SS216
D214	Diode	1SS216
D215	Varicap	1SV100 (#5, #9 only)
D216	Diode	1SS211
D217	Diode	1SS211
D219	Diode	1SS211
D220	Diode	1SS211
D221	Diode	1SS211
FI201	Crystal	21M1583/UM-1 (#04, #05, #07, #09 only)
FI202	MC	CFU 455E2
X201	Crystal	CR-70
X202	Discriminator	CDB 455C7A
X203	Crystal	CR-107 (#04 only)
X203	Crystal	CR-106 (#05, #07, #09 only)
L201	Coil	LA174
L202	Coil	LA173
L203	Coil	LA173

Values without units are:

— Ω (Resistor)— μ F (Capacitor)

[PLL] UNIT

REF.NO.	DESCRIPTION	PART NO.	
L204	Coil	LA173	
L205	Coil	LA173	
L206	Coil	LS264	
L207	Coil	LS264	
L208	Coil	LS263	
L214	Coil	LA232	
L217	Coil	LA126	
L218	Coil	LA233	
L219	Coil	LA242	
L220	Coil	LAL03NA R82M	
L221	Coil	LA232	
L222	Coil	LA147	
L223	Coil	LA147	
L224	Coil	LA147	
L225	Coil	LA233	
L226	Coil	LAL03NA 102K	
R201	Resistor	39k	ELR10
R202	Resistor	15k	ELR10
R203	Resistor	47	ELR10
R204	Resistor	15k	ELR10
R205	Resistor	39k	ELR10
R206	Resistor	470	ELR10
R207	Resistor	56k	ELR10
R208	Resistor	12k	ELR10
R209	Resistor	3.9k	ELR10
R210	Resistor	470k	ELR10
R211	Resistor	100	ELR10
R212	Resistor	22k	ELR10
R213	Resistor	1.5k	ELR10
R214	Resistor	1.5k	ELR10
R215	Resistor	47k	ELR10
R216	Resistor	1.5k	ELR10
R217	Resistor	470	ELR10
R218	Resistor	4.7k	ELR10
R219	Resistor	1M	ELR10
R220	Resistor	15k	ELR10
R221	Trimmer	H0521A 10K	
R222	Resistor	680k	ELR10
R223	Resistor	12k	ELR10
R224	Resistor	470	ELR10
R226	Trimmer	H0521A 100k	
R229	Resistor	10k	R10
R230	Resistor	6.8k	ELR10
R231	Resistor	1.8k	ELR10
R236	Resistor	6.8k	ELR10
R237	Resistor	22k	ELR10
R238	Resistor	10k	ELR10
R239	Resistor	1.2k	ELR10
R240	Resistor	560	ELR10
R241	Resistor	47	ELR10
R242	Resistor	1k	ELR10
R244	Resistor	10	ELR10
R245	Resistor	4.7k	ELR10
R246	Resistor	4.7k	ELR10
R247	Resistor	330	ELR10
R248	Resistor	1.0k	ELR10
R249	Resistor	1.8	ELR10
R250	Resistor	22k	ELR10
R251	Resistor	220k	ELR10
R252	Resistor	220k	ELR10 (#04, #07 only)

[PLL] UNIT

REF.NO.	DESCRIPTION	PART NO.	
R252	Resistor	39k	ELR10 (#05, #09 only)
R253	Resistor	220k	ELR10 (#04, #07 only)
R253	Resistor	39k	ELR10 (#05, #09 only)
R254	Resistor	5.6k	ELR10
R255	Resistor	100	ELR10
R256	Resistor	220k	ELR10 (#05, #07 only)
R256	Resistor	39k	ELR10 (#09 only)
R257	Resistor	470k	ELR10 (#05, #09 only)
R259	Resistor	4.7k	ELR10
R260	Resistor	22k	ELR10
R261	Resistor	87k	ELR10
R262	Resistor	560k	ELR10
R263	Resistor	8.2k	ELR10
R264	Trimmer	H0521A 47k	
R265	Resistor	22k	R10
R266	Resistor	1.8k	ELR10
R267	Trimmer	H0521A 2.2k	
R268	Thermistor	112-503-2	
R269	Resistor	47k	ELR10
R270	Resistor	10k	ELR10
R271	Resistor	1M	ELR10
R272	Resistor	150k	ELR10
R273	Resistor	5.6k	ELR10
R274	Resistor	47k	ELR10
R275	Resistor	27	ELR10
R276	Resistor	27k	ELR10
R277	Resistor	6.8k	ELR10
R278	Resistor	1k	ELR10
R279	Resistor	220	ELR10
R280	Resistor	10k	ELR10
R281	Resistor	220k	ELR10
R282	Resistor	330	ELR10
R283	Resistor	390k	ELR10
C201	Ceramic	5P	50V
C202	Ceramic	3P	50V
C203	Trimmer	ECR-GA006A30	
C204	Ceramic	15P	50V
C205	Ceramic	3P	50V
C206	Trimmer	ECR-GA006A30	
C207	Ceramic	0.35P	50V
C208	Trimmer	ECR-GA006A30	
C209	Ceramic	3P	50V
C210	Ceramic	0.001	50V
C211	Ceramic	0.001	50V
C212	Ceramic	3P	50V
C215	Ceramic	3P	50V
C216	Trimmer	ECR-GA006A30	
C217	Ceramic	0.35P	50V
C218	Trimmer	ECR-GA006A30	
C219	Ceramic	3P	50V
C222	Ceramic	0.001	50V
C223	Ceramic	2P	50V
C224	Ceramic	0.001	50V
C225	Ceramic	43P	50V
C226	Ceramic	5P	50V

Values without units are:

-Ω (Resistor)

-μF (Capacitor)

[PLL] UNIT

REF.NO.	DESCRIPTION	PART NO.		
C227	Ceramic	47P 50V	DD105TH	
C228	Ceramic	0.001 50V		
C229	Ceramic	0.001 50V		
C230	Ceramic	22P 50V		
C231	Ceramic	120P 50V		
C232	Ceramic	68P 50V		
C233	Ceramic	0.1 16V		
C234	Electric	0.1 50V	RC2	
C235	Ceramic	82P 50V		
C236	Ceramic	0.001 50V		
C237	Ceramic	0.0033 50V		
C238	Ceramic	15P 50V		
C239	Ceramic	470P 50V		
C240	Ceramic	470P 50V		
C241	Electrolytic	1 50V	RC2	
C248	Mylar	0.0022 50V		
C249	Electrolytic	0.47 50V	RC2	
C251	Barrier Layer	0.1 16V		
C252	Electrolytic	22 6.3V	RC2	
C253	Electrolytic	22 6.3V	RC2	
C254	Barrier Layer	0.01 50V		
C257	Ceramic	0.001 50V		
C263	Ceramic	12P 50V		
C264	Ceramic	470P 50V		
C265	Ceramic	10P 50V		
C266	Ceramic	47P 50V		
C268	Ceramic	0.001 50V		
C269	Ceramic	5P 50V		
C270	Ceramic	47P 50V		
C272	Ceramic	0.001 50V		
C274	Ceramic	12P 50V		
C275	Ceramic	0.001 50V		
C276	Ceramic	1P 50V		
C277	Ceramic	5P 50V		
C278	Ceramic	7P 50V		
C279	Ceramic	7P 50V		
C280	Ceramic	1P 50V		
C281	Ceramic	5P 50V		
C282	Ceramic	0.001 50V		
C284	Ceramic	6P 50V		
C285	Ceramic	30P 50V		
C286	Ceramic	470P 50V		
C287	Ceramic	7P 50V		
C288	Ceramic	7P 50V		
C289	Ceramic	5P 50V		
C290	Ceramic	12P 50V		
C291	Ceramic	10P 50V		
C293	Ceramic	0.001 50V		
C294	Tantalum	CS15E0J100		
C295	Tantalum	CS15E1V0R1		
C296	Electrolytic	10 16V	RC2	
C297	Ceramic	0.001 50V		
C298	Trimmer	ECR-GA010D30		
C299	Ceramic	22P 50V		
C300	Ceramic	220P 50V		
C301	Ceramic	100P 50V (#04, #07 only)		
C302	Ceramic	0.001 50V (#05, #09 only)		
C303	Ceramic	0.01 50V		
C304	Ceramic	470P 50V		
C306	Ceramic	47P 50V		
C307	Ceramic	47P 50V		

[PLL] UNIT

REF.NO.	DESCRIPTION	PART NO.		
C308	Ceramic	47P 50V		
C309	Ceramic	47P 50V		
C311	Ceramic	470P 50V		
C312	Ceramic	470P 50V		
C313	Ceramic	470P 50V		
C314	Ceramic	470P 50V		
C315	Ceramic	470P 50V		
C316	Ceramic	470P 50V		
C317	Ceramic	0.001 50V		
C318	Ceramic	4P 50V		
C319	Ceramic	470P 50V		
C320	Ceramic	6P 50V		
C321	Barrier Layer	0.1 16V		
C322	Ceramic	47P 50V		
C324	Ceramic	0.001 50V		
C325	Ceramic	0.001 50V		
C326	Ceramic	47P 50V		
C327	Ceramic	47P 50V		
C328	Ceramic	47P 50V		
C329	Ceramic	47P 50V		
C330	Ceramic	47P 50V (#05, #09 only)		
C331	Ceramic	47P 50V		
C332	Ceramic	0.001 50V		
C333	Ceramic	0.001 50V		
C334	Ceramic	0.001 50V		
C335	Ceramic	0.001 50V		
C336	Ceramic	0.001 50V		
C337	Ceramic	47P 50V		
C338	Tantalum	DNIC 4R7M	16V	
C339	Tantalum	DNIC 4R7M	16V	
C340	Ceramic	0.001 50V		
C341	Ceramic	470P 50V		
C342	Ceramic	470P 50V		
J201	Connector	BNC-RM-106		
J202	Connector	HSJ 1102-01-040		
J203	Connector	HEC 0747-01-010		
J204	Connector	HSJ 0836-01-010		
J205	Connector	171255-1		
J206	Connector	171255-1		
EP201	P.C. Board	B-816 I		
EP203	Beads Core	DL-20P2.6-3-1.2H		
EP204	Irrax Tube	$\phi=0.7$ l=9mm		
EP205	Irrax Tube	$\phi=0.7$ l=29mm		
EP206	Filter	41590		
EP209		(W)		
EP211	Bead Core	DL-20P2.6-3-1.2H		
EP212	Bead Core	DL-20P2.6-3-1.2H		
EP214	Aluminum sheet	(H)		
W201	Jumper	JPW-02A		
W202	Wire	72/99/50/X98/X98		
W203	Wire	72/99/50/X98/X98		

Values without units are:

- Ω (Resistor)- μ F (Capacitor)

[VCO] UNIT

REF.NO.	DESCRIPTION	PART NO.	
Q701	Transistor	DTC124-K	
Q702	Transistor	2SC3356	
Q703	Transistor	2SC3356	
D701	Varicap	1SV153	
D702	Diode	1SS216	
D703	Diode	1SS216	
L701	Coil	LA182	
L702	Choke	LQN5N	1R0
L703	Coil	LA135	
R701	Resistor	1k	R10
R702	Resistor	150	MCR10
R703	Resistor	4.7k	MCR10
R704	Resistor	47k	MCR10
R705	Resistor	6.8k	MCR10
R706	Resistor	4.7k	MCR10
R707	Resistor	220	MCR10
R708	Resistor	33k	MCR10
R710	Resistor	6.8k	MCR10
R711	Resistor	1.8k	MCR10
R712	Resistor	220	MCR10
R713	Resistor	47k	MCR10
C701	Ceramic	470P	50V
C702	Trimmer	TZB04N100BA	
C703	Monolithic	5P	50V GR40
C704	Monolithic	470P	50V GR40
C705	Trimmer	TZB04N100BA	
C706	Monolithic	6P	50V GR40
C707	Monolithic	5P	50V GR40
C708	Monolithic	12P	50V GR40
C709	Monolithic	470P	50V GR40
C710	Monolithic	8P	50V GR40
C711	Monolithic	470P	50V GR40
C712	Monolithic	0.5P	50V GR40
C713	Monolithic	470P	50V GR40
C715	Ceramic	6P	50V
EP701	P.C. Board	B-930B	

[LOGIC] UNIT

REF.NO.	DESCRIPTION	PART NO.		
IC401	MPU	HD44795B60		
Q401	Transistor	2SC2712-Y		
Q402	Transistor	2SA1162-Y		
Q403	Transistor	2SA1162-Y		
D401	Diode	1SS187 (#04, #07, #09 only)		
D401	Diode	1SS190 (#05, only)		
D402	Diode	1SS181		
D407	Diode	1SS187 (#05, #07, #09 only)		
D408	Diode	1SS190 (#04, only)		
D409	Diode	RD4.7MB3		
R401	Resistor	6.8k	MCR10	
R402	Resistor	15k	MCR10	
R403	Resistor	1M	MCR10	
R404	Resistor	15k	MCR10	
R405	Resistor	100k	MCR10	
R406	Resistor	100k	MCR10	
R407	Resistor	100k	MCR10	
R408	Resistor	15k	MCR10	
R409	Resistor	270k	MCR10	
R410	Resistor	120k	MCR10	
R411	Resistor	68k	MCR10	
R412	Resistor	33k	MCR10	
R413	Resistor	270k	MCR10	
R414	Resistor	47k	MCR10	
R415	Resistor	47k	MCR10	
R416	Resistor	47k	MCR10	
R417	Resistor	47k	MCR10	
R418	Resistor	22k	MCR10	
R419	Resistor	22k	MCR10	
R420	Resistor	100k	MCR10	
R421	Resistor	100k	MCR10	
R422	Resistor	100k	MCR10	
R423	Resistor	1M	MCR10	
R424	Resistor	100k	MCR10	
C401	Monolithic	470P	50V	GR40
C402	Monolithic	470P	50V	GR40
C403	Monolithic	470P	50V	GR40
C404	Ceramic	470P	50V	
C405	Monolithic	0.1	25V	GR40
C406	Monolithic	0.01	25V	GR40
C407	Monolithic	0.001	50V	GR40
C407	Monolithic	0.001	50V	GR40
DS401	Lamp	BQ031-22403A		
DS402	LCD	LP-156AE		
SP401	Speaker	40P-177B		
EP401	Microphone	KUC2023-01-006		
EP402	Rubber Conductor	SRCN-297B		

Values without units are:

—Ω (Resistor)

—μF (Capacitor)

[LOGIC] UNIT

REF.NO.	DESCRIPTION	PART NO.
EP403	Reflection plate	42616
EP404	P.C. Board	B-935C
EP405	F.P.C. Board	B-813A
EP406	F.P.C. Board	B-822A (#05 only)
W401	Wire	23/04/85/W01/W01
W402	Wire	23/00/40/W01/W01 (#04, #07 only)
W402	Wire	23/00/95/W01/W01 (#05, #09 only)

[TONE] UNIT (#05, #09 ONLY)

REF.NO.	DESCRIPTION	PART NO.
IC501	IC	LR4087
IC502	IC	TC4094BP
IC503	IC	S-7116A
Q501	Transistor	2SC2603-F
Q502	Transistor	2SC2603-F
Q503	Transistor	2SC2603-F
Q504	Transistor	2SC2603-F
Q505	Transistor	2SA1345
Q506	Transistor	2SC2603-F
D501	Diode	1SS211
D502	Diode	1SS211
D503	Diode	1SS211
D504	Diode	1SS211
D505	Diode	1SS211
D506	Diode	1SS211
X501	Ceralock	CSA3.58MG18
X502	Crystal	3577.545 kHz
R501	Array	RKL5S 105J
R502	Array	RKL5S 473J
R504	Resistor	22k ELR10
R505	Resistor	150k ELR10
R506	Resistor	100k ELR10
R507	Trimmer	H0521A 10k
R508	Resistor	33k ELR10
R509	Resistor	47k ELR10
R510	Trimmer	H0521A 100k
R511	Resistor	68k ELR10
C501	Ceramic	470P 50V
C502	Ceramic	39P 50V
C503	Ceramic	30P 50V
C504	Ceramic	47P 50V
C505	Electrolytic	4.7 25V RC3
C506	Electrolytic	0.47 50V RC3
C507	Ceramic	470P 50V
C508	Electrolytic	22 6.3V RC3
C510	Ceramic	47P 50V
C511	Ceramic	39P 50V
C512	Electrolytic	0.47 25V RC3
C513	Electrolytic	0.22 50V RC3
EP501	P.C. Board	B-814
EP504	Irrax Tube	$\phi=0.7$ l=5mm
W501	Wire	72/99/20/X98/X98
W502	Wire	72/99/20/X98/X98

Values without units are:

- Ω (Resistor)

- μ F (Capacitor)

[TONE-CALL] UNIT (#04 ONLY)

REF.NO.	DESCRIPTION	PART NO.	
IC601	IC	TC 5082P	
Q601	Transistor	2SA1115-E	
D601	Diode	1SS211	
X601	Crystal	HC-18/T7.1680MHz	
R601	Resistor	220k	ELR10
R602	Resistor	22k	ELR10
R603	Trimmer	10k	ELR10
R604	Resistor	47k	ELR10
C601	Barrier Layer	0.0047	50V
C602	Electrolytic	0.1	50V
C603	Ceramic	470P	50V
C604	Ceramic	47P	50V
C605	Ceramic	10P	50V
C606	Ceramic	10P	50V
C607	Ceramic	470P	50V
EP601	P.C. Board	B-850	
EP602	Irrax tube	$\phi=0.7$ l=5mm	
EP603	Cushion	(l) 22.8 + =2.5	
W601	Wire	23/02/65/D21/W01	
W602	Wire	23/03/80/D21/W01	
W603	Wire	23/04/80/D21/W01	
W604	Wire	23/05/65/D21/W01	
W605	Wire	23/00/65/D21/W01	
W606	Wire	72/99/40/X98/X98	

Values without units are:

— Ω (Resistor)

— μ F (Capacitor)

SECTION 11 IC, TRANSISTOR AND DIODE PIN CONNECTIONS

• ICs

μPC358C
(Dual Driver)
IC101

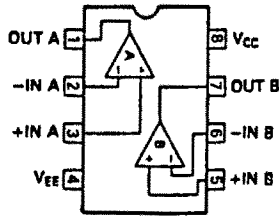

TC4071BP
(Quad 2-Input OR Gate)
IC102

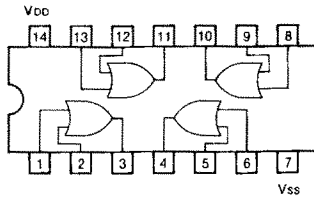

TC4069UBP
(Hex Inverter)
IC103

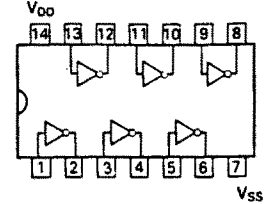

S81250H-G
(3-Terminal Voltage Regulator)
IC104

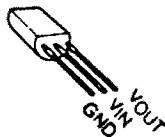

TA75393P
(Dual Comparator)
IC105

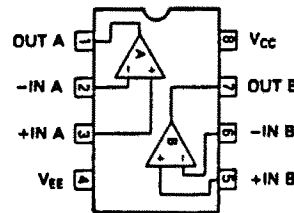

LR4087
(DTMF Encoder)
IC501 (#05, #09)

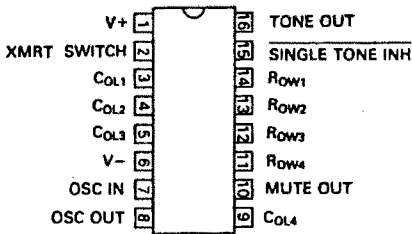

TC4094BP
(8-Stage Shift-and-Store Bus Register)
IC502 (#05, #09)

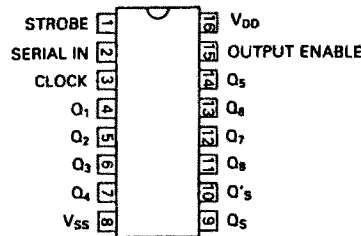

S-7116A
(Subaudible Tone Encoder)
IC503 (#05, #09)

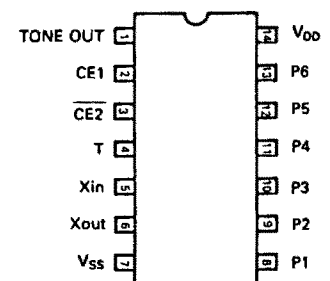

TC5082
(Oscillator and 12-Stage Driver)
IC601 (#04)



• ICs

MC3357P (Low Power FM IF)

IC201

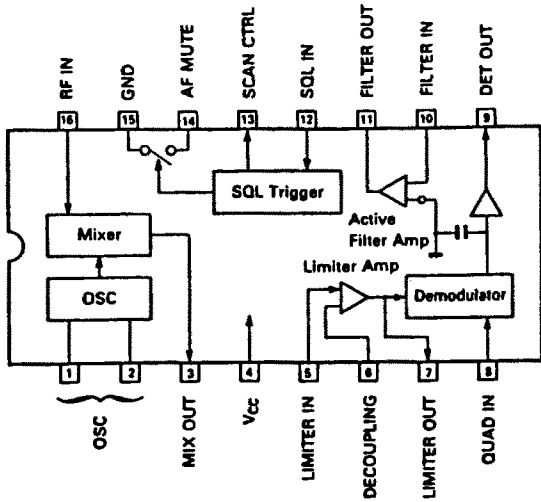

μPB571C (Low Power Prescaler)

IC203

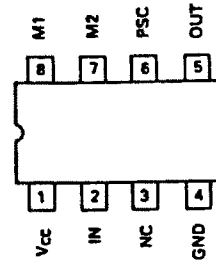

μPD2834C (PLL Frequency Synthesizer)

IC204

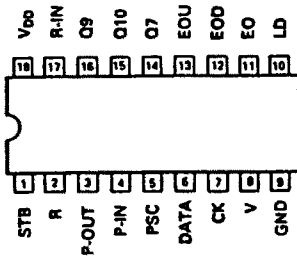

SC-1026 (UHF Power Amplifier)

IC202

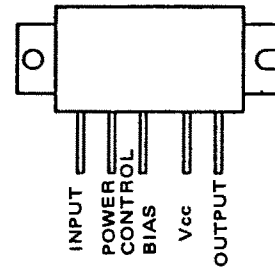

HD44795B60 (MPU)

IC401

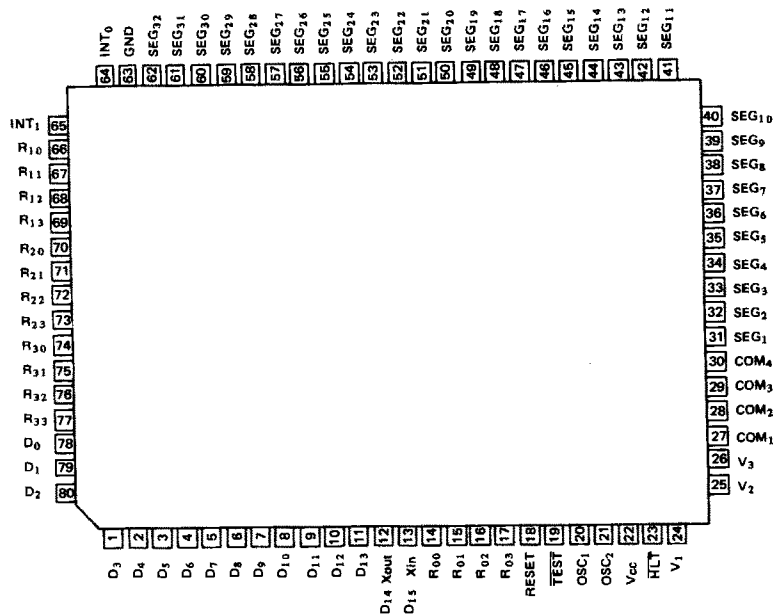

• Transistors

2SC2603 F

Q101, Q102, Q104, Q105, Q106, Q110, Q112, Q114, Q118, Q119, Q130, Q132, Q213, Q215, Q218, Q501, (#05, #09), Q502(#05,#09), Q503,(#05, #09), Q504 (#05, #09),Q506 (#05, #09)

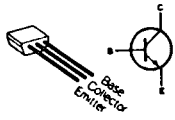

2SA1048 GR

Q219

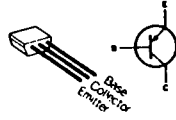

2SB909M R

Q111, Q113, Q115, Q120, Q131, Q214

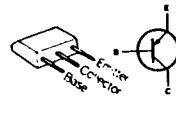

2SD1225M R

Q122

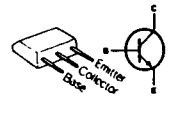

2SC2407A

Q212

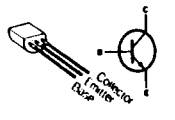

2SC2026

Q201, Q202, Q203, Q208, Q211, Q220,

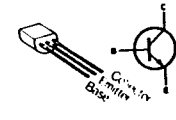

2SA111S E

Q103, Q107, Q108, Q109, Q116, Q117, Q121, Q129, Q216, Q217, Q601(#04)

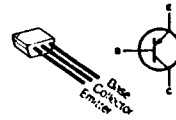

2SK241 Y

Q204

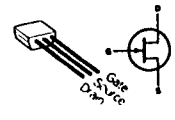

2SA1345

Q505 (#05, #09)

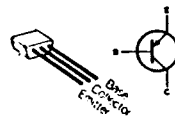

2SC2668

Q205, Q206

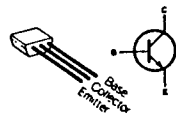

2SB561 C

Q210

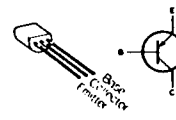

2SC2712 Y

Q401

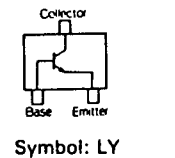

2SA1162 Y

Q402, Q403

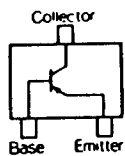

Symbol: SY

DTC124 K

Q701

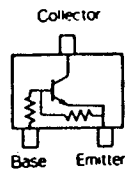

Symbol: 25

2SC3356

Q702, Q703

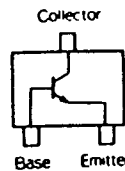

Symbol: R

• Diodes

1SS187

D401(#04), D407 (#05, #07, #09)



Symbol: D3

1SS190

D408 (#04)



Symbol: E3

1SS181

D402



Symbol: A3

RD4.7M B3

D409



Symbol: 473

IC-04A/AT/E

LOGIC

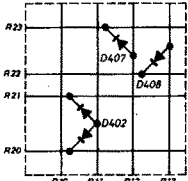

D401 04AT(AT) 1SS190
 D4E 1SS187
 D402 1SS181
 D407 1SS187
 D408 1SS190

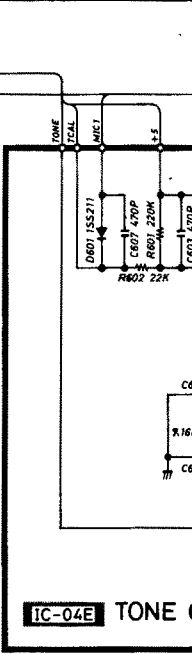
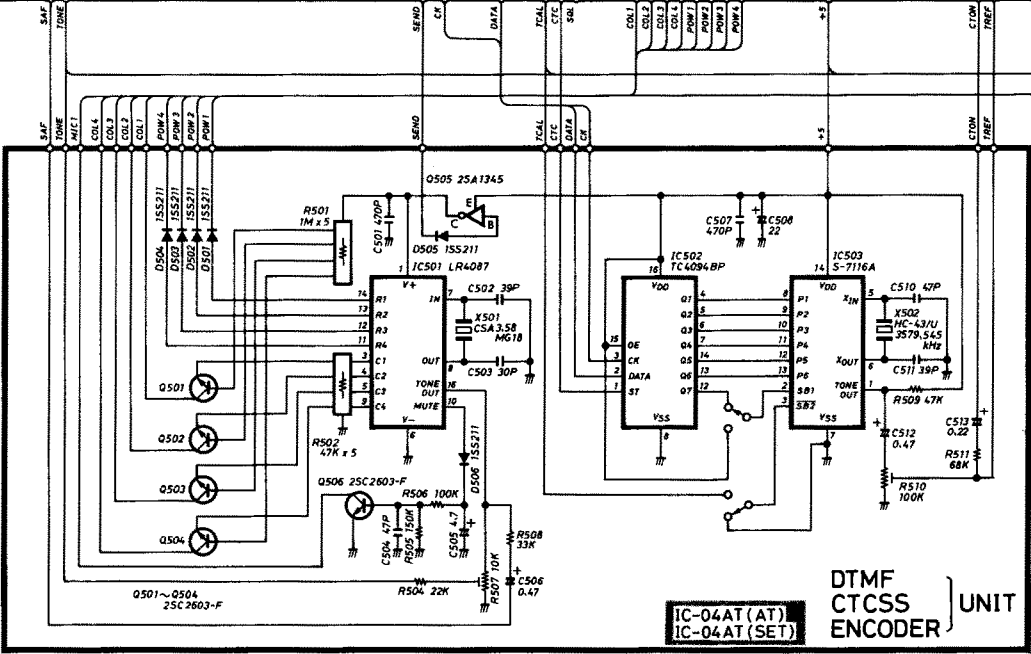
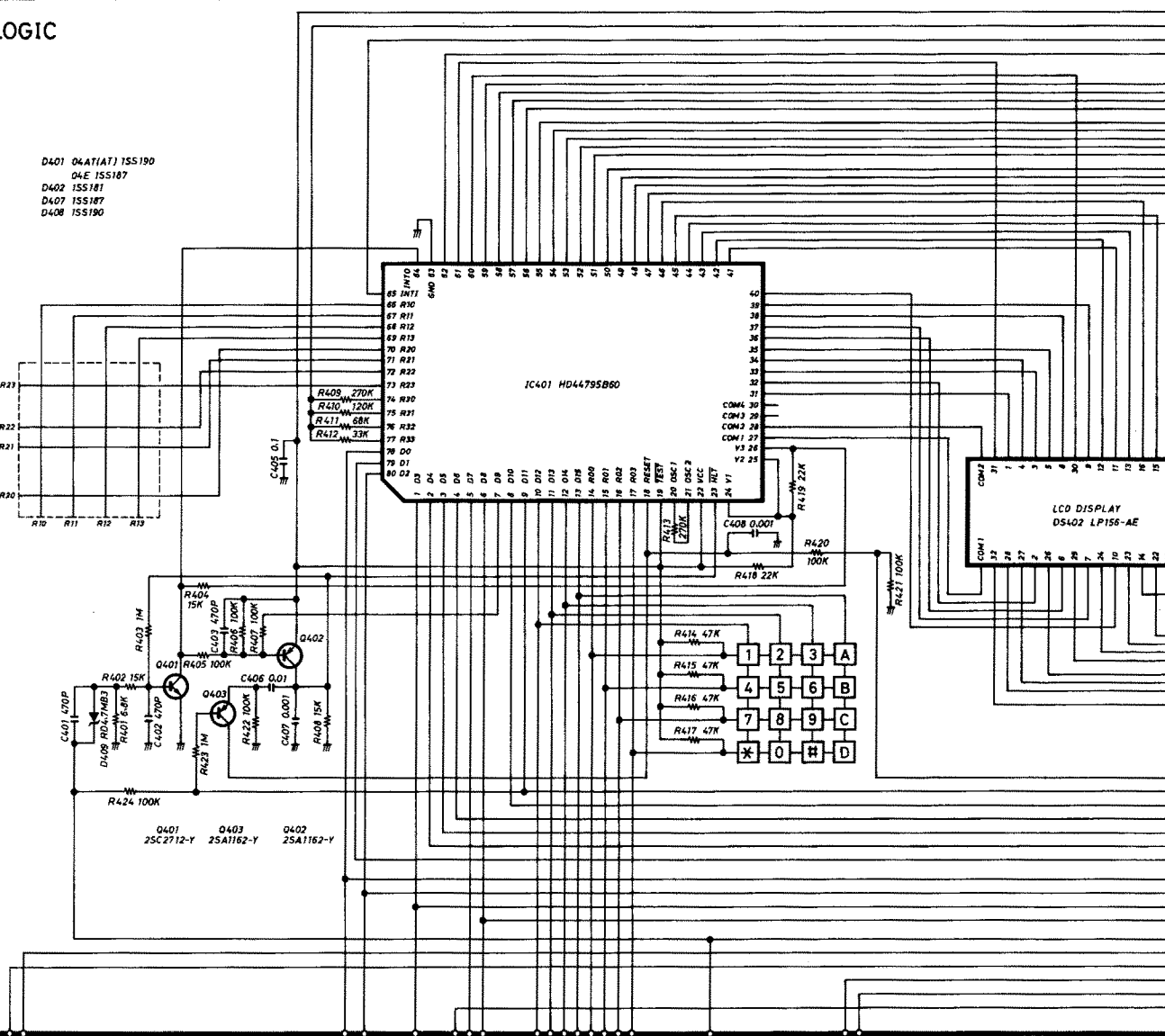
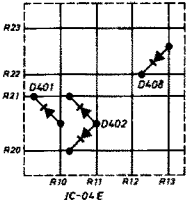
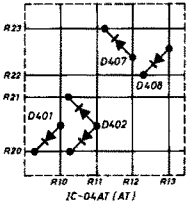

DTMF
 CTCSS
 ENCODER } UNIT

IC-04E TONE C...

