



# SERVICE MANUAL

UHF FM TRANSCEIVER

# IC-U16

---

---

---

---

---

---

## INTRODUCTION

---

This service manual describes the latest information for the following transceivers at the time of publication.

VERSION NO.	VERSION	SYMBOL	FREQUENCY RANGE
# 01	U.S.A.	USA	450 ~ 490 MHz
# 02	U.K.	UK	420 ~ 470 MHz
# 03	Australia	AUS	450 ~ 490 MHz
# 04	U.S.A.-1	USA-1	400 ~ 430 MHz
# 05	U.S.A.-2	USA-2	480 ~ 512 MHz
# 06	Sweden	SWE	400 ~ 430 MHz

To upgrade quality, all electronic and mechanical parts and internal circuits are subject to change without notice or obligation.

---

## ORDERING PARTS

---

Be sure to include the following four points when ordering replacement parts :

1. 10-digit order numbers
2. Component part number and name
3. Equipment model name and unit name
4. Quantity required

<SAMPLE ORDER>

111000070 IC     μ PC358C IC-U16 MAIN UNIT     5 pieces  
2510000140 Speaker 40P-157B IC-U16 DISPLAY UNIT 8 pieces

Addresses are provided on the inside back cover for your convenience.

---

## DANGER

---

**NEVER** connect the transceiver to an AC outlet or to a DC power supply that uses more than 16 V. This will ruin the transceiver.

**DO NOT** expose the transceiver to rain, snow or any liquids.

**DO NOT** reverse the polarities of the power supply when connecting the transceiver.

**DO NOT** apply an RF signal of more than 20 dBm (100 mW) to the antenna connector. This could damage the transceiver's front end.

---

## REPAIR NOTE

---

1. Make sure a problem is internal before disassembling the transceiver.
2. **DO NOT** open the transceiver until the transceiver is disconnected from the power source.
3. **DO NOT** force any of the variable components. Turn them slowly and smoothly.
4. **DO NOT** short any circuits or electronic parts. An insulated turning tool **MUST** be used for all adjustments.
5. **DO NOT** keep power ON for a long time when the transceiver is defective.
6. **DO NOT** transmit power into a signal generator or a sweep generator.
7. **ALWAYS** connect a 40 dB ~ 50 dB attenuator between the transceiver and a deviation meter or spectrum analyzer when using such test equipment.
8. **READ** the instructions of test equipment thoroughly before connecting equipment to the transceiver.

## TABLE OF CONTENTS

<b>SECTION</b>	<b>1</b>	<b>SPECIFICATIONS.....</b>	<b>1 - 1</b>
<b>SECTION</b>	<b>2</b>	<b>INSIDE VIEWS.....</b>	<b>2 - 1</b>
<b>SECTION</b>	<b>3</b>	<b>CIRCUIT DESCRIPTION.....</b>	<b>3 - 1 ~ 7</b>
	3 - 1	RECEIVER CIRCUITS.....	3 - 1
	3 - 2	TRANSMITTER CIRCUITS.....	3 - 2
	3 - 3	PLL CIRCUITS.....	3 - 2
	3 - 4	POWER SUPPLY CIRCUITS.....	3 - 3
	3 - 5	LOGIC CIRCUITS.....	3 - 3
<b>SECTION</b>	<b>4</b>	<b>MECHANICAL PARTS AND DISASSEMBLY.....</b>	<b>4 - 1 ~ 5</b>
	4 - 1	DISASSEMBLY OF THE CASE.....	4 - 1
	4 - 2	DISASSEMBLY OF THE TOP PANEL.....	4 - 3
	4 - 3	PA / EXTERNAL JACK ASSEMBLY.....	4 - 3
	4 - 4	SPEAKER / MICROPHONE ASSEMBLY.....	4 - 4
	4 - 5	PTT SPRING ASSEMBLY.....	4 - 4
	4 - 6	UNIT BOTTOM ASSEMBLY.....	4 - 5
<b>SECTION</b>	<b>5</b>	<b>ADJUSTMENT PROCEDURES.....</b>	<b>5 - 1 ~ 5</b>
	5 - 1	PREPARATION BEFORE SERVICING.....	5 - 1
	5 - 2	PLL ADJUSTMENT.....	5 - 2
	5 - 3	TRANSMITTER ADJUSTMENT.....	5 - 3
	5 - 4	RECEIVER ADJUSTMENT.....	5 - 5
<b>SECTION</b>	<b>6</b>	<b>VOLTAGE DIAGRAMS.....</b>	<b>6 - 1 ~ 4</b>
<b>SECTION</b>	<b>7</b>	<b>PARTS LIST.....</b>	<b>7 - 1 ~ 8</b>
<b>SECTION</b>	<b>8</b>	<b>BOARD LAYOUTS.....</b>	<b>8 - 1 ~ 7</b>
<b>SECTION</b>	<b>9</b>	<b>BATTERY PACK SCHEMATIC DIAGRAM.....</b>	<b>9 - 1 ~ 2</b>
<b>SECTION</b>	<b>10</b>	<b>BLOCK DIAGRAM.....</b>	<b>10 - 1</b>

## SECTION 1 SPECIFICATIONS

### ■ GENERAL

- Frequency coverage : 

Version	Frequency coverage
U.S.A. (3 versions)	400~430 MHz
	450~490 MHz
	480~512 MHz
U.K.	420~470 MHz
Australia	450~490 MHz
Sweden	400~430 MHz
  
- Mode : FM (16K0F3E)  
FM (8K50F3E) (narrow type)
- Number of channels : 16
- Antenna impedance : 50  $\Omega$  unbalanced
- Channel spacing : 25 kHz  
12.5 kHz (narrow type)
- Power supply requirement : Icom battery pack or case  
EXTERNAL DC POWER JACK 12~15 V DC  
(negative ground)
- Current drain : 

Transmit	HIGH	1.7 A
	LOW	850 mA
Receive	Power saver ON	35 mA
	Squelched	70 mA
	Max. audio output	200 mA

  
(With CM-3 or CM-8)
- Usable temperature range : - 30  $^{\circ}$ C ~+60  $^{\circ}$ C
- Frequency stability :  $\pm$  0.0005% ( - 30  $^{\circ}$ C ~+60  $^{\circ}$ C )
- Dimensions (with CM-8) : 65(W)  $\times$  196(H)  $\times$  38(D) mm  
2.6(W)  $\times$  7.7(H)  $\times$  1.5(D) in  
(Projections not included)
- Weight (with CM-8) : 595 g (1.3 lb)

### ■ TRANSMITTER

- Output power : 

HIGH	With CM-7	5 W
	With CM-3 or CM-8	2.5 W
LOW	With CM-3 or CM-8	500 mW
- Modulation system : Variable reactance frequency modulation
- Max. frequency deviation :  $\pm$  5 kHz
- Spurious emissions : - 60 dB
- Harmonic emissions : - 60 dB

### ■ RECEIVER

- Receive system : Double-conversion superheterodyne system
- Intermediate frequency : 1st 21.8 MHz  
2nd 455 kHz
- Sensitivity : 0.4  $\mu$ V for 12 dB SINAD
- Squelch sensitivity : 0.4  $\mu$ V  
(threshold)
- Adjacent channel selectivity : - 65 dB
- Audio output power : 500 mW with an 8  $\Omega$  load.
- Audio output impedance : 8  $\Omega$

All stated specifications are subject to change without notice or obligation.

## SECTION 2 INSIDE VIEWS

### LOGIC/MAIN UNIT

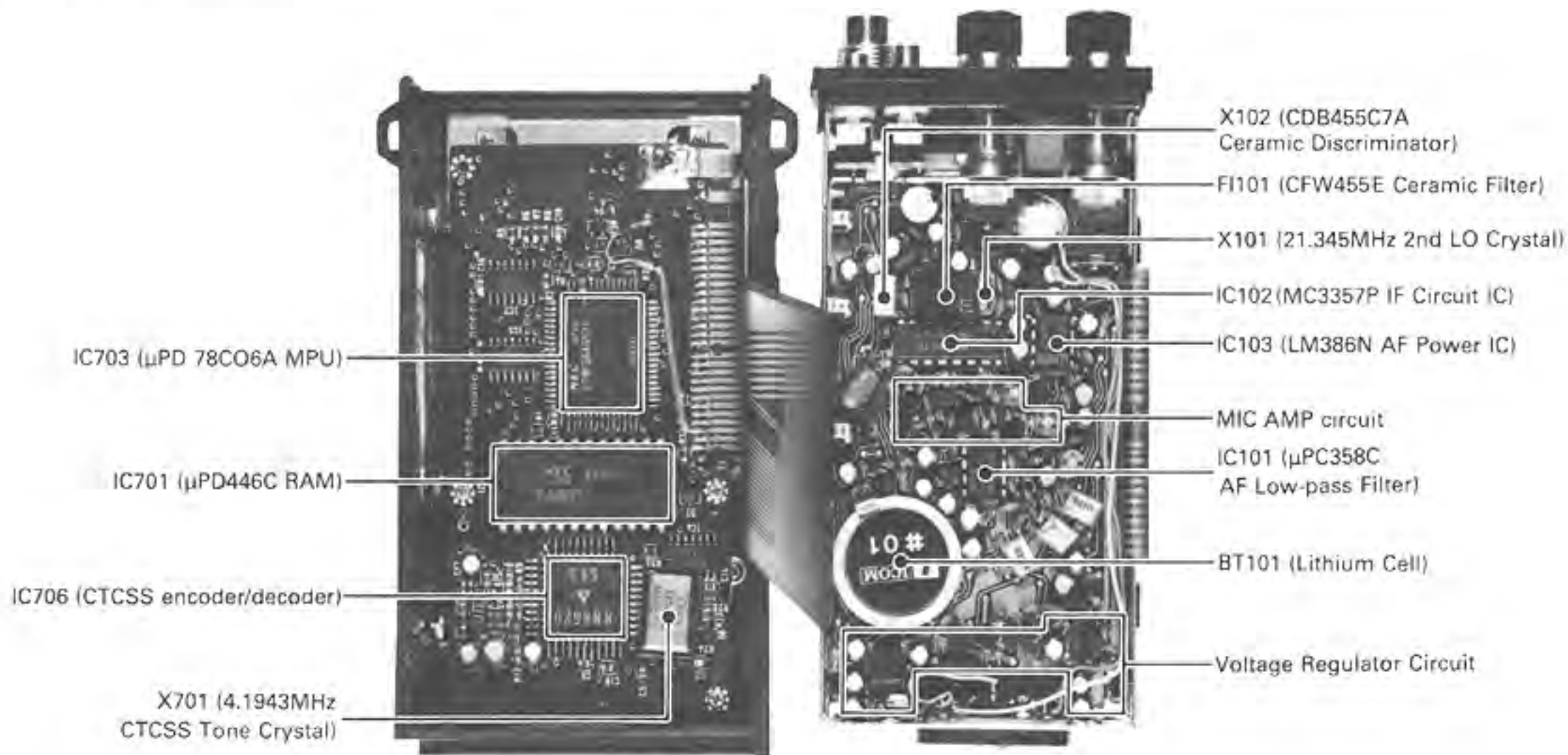

LOGIC UNIT

MAIN UNIT

### PLL/DISPLAY UNIT

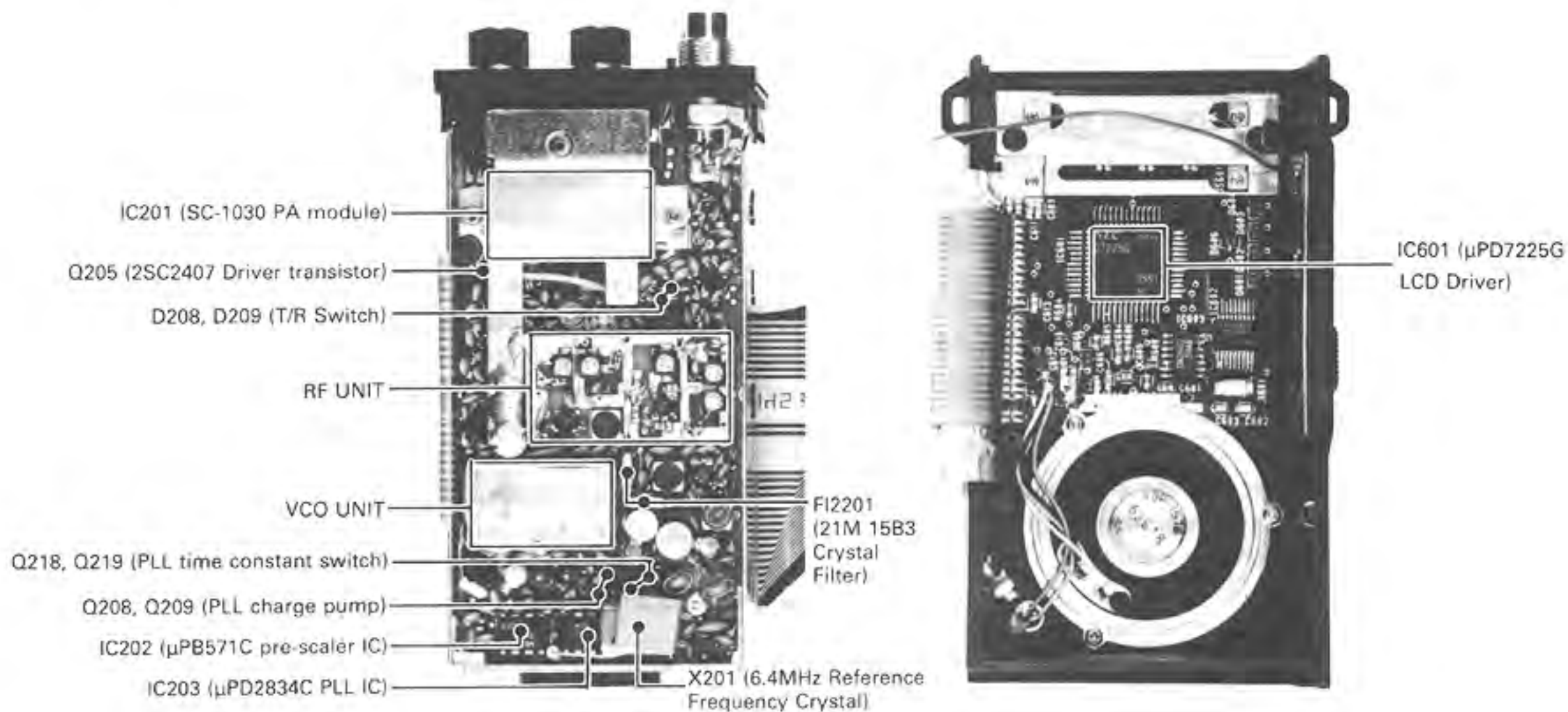

PLL UNIT

DISPLAY UNIT

## SECTION 3 CIRCUIT DESCRIPTION

### 3 - 1 RECEIVER CIRCUITS

#### 3 - 1 - 1 ANTENNA SWITCHING CIRCUIT

Input signals from the antenna connector are fed into the antenna switching circuit through Chebyshev low-pass filters consisting of C245, C244, C243, L212 and L211 in the PLL unit. The antenna switching circuit employs a quarter wave circuit consisting of D208, D209, L209 and C246.

#### 3 - 1 - 2 RF AMPLIFIER CIRCUIT

Signals from the switching circuit pass through bandpass filters consisting of L501, C501, D501, C504, D502 and L502 on the RF unit. These bandpass filters reduce interference from out-of-band signals. Signals passed through the bandpass filters are fed into gate 1 of Q501, the first RF amplifier, and are amplified.

Output signals from Q501 are again passed through bandpass filters which consist of L503, L504, C509, D503, C512, D504, L505, C515, D505 and L506, and are then fed into the gate 1 of Q502.

Diodes D501 to D505 are varactor diodes that track the bandpass filters and are controlled by the PLL lock voltage. These diodes tune the center frequency of the bandpass filters for wide bandwidth reception and a good image response rejection ratio.

Signals from the bandpass filters are fed into gate 1 of Q502. Local oscillator signals from the PLL unit also are fed into gate 2 of Q502 through C517. Q502 is a first mixer which converts RF signals into 21.8MHz first intermediate frequencies and outputs them at L203.

#### 3 - 1 - 3 INTERMEDIATE FREQUENCY CIRCUIT

The first intermediate signal from L201 is filtered further from out-of-band interference through a matched pair of monolithic crystal filters that are FI201 and is then amplified at Q201.

The signal amplified at Q201 is fed into IC102 on the MAIN unit through the limiter circuit (D201, D202) and tuning circuit (L203), both on the RF unit.

IC102 incorporates in one package a second local oscillation circuit, a second mixer, a limiter amplifier, an active filter, and a quadrature detector circuit.

The first intermediate frequency signal enters IC102 (pin 16) and mixes with a second local oscillator frequency (21.345MHz) generated by X101. The 455kHz second intermediate frequency signal is then output from pin 3. This signal passes through a high-performance ceramic filter (FI101), and is amplified at a limiter amplifier.

Output signals from the limiter amplifier are separated. One of the signals enters a quadrature detector circuit, and the other exits from pin 7. The signal output from pin 7 enters pin 8 through ceramic resonator X102, and then both signals are detected at a quadrature detector circuit inside IC102. The resulting audio signal is output from pin 9 and is then applied to IC706 (pin 29) on the LOGIC unit.

#### 3 - 1 - 4 AUDIO FREQUENCY CIRCUIT

IC706 incorporates a CTCSS encoder/decoder, an AF amplifier, and a dual AF filter circuit.

The signal applied to IC706 is amplified and then exits from pin 18. This signal is amplified at Q702 through a low-pass filter consisting of R715 and C711. This low-pass filter is a de-emphasis circuit which has  $-6\text{dB/oct}$  characteristics.

Output signals from Q702 re-enter the MAIN unit and are fed into AF SWITCH (Q120). This transistor cuts the AF signal when RX MUTE is operating or the squelch is closed.

The signals that enter Q120 are then fed into an AF power amplifier circuit (IC103 pin 3) through AF volume control R161. The gain of IC103 is fixed by R162 and C155 which are connected across pins 1 and 8. The speaker is driven at more than 500mW of AF output by IC103 with an 8 ohm load and 8.4V Vcc.

The power source for IC103 consists of Q123 and D113 which protect it from excess voltage, maintaining the voltage at less than 12V.

#### 3 - 1 - 5 SQUELCH CIRCUIT

A portion of signals output from IC102 (pin 9) pass through R148, Squelch volume and is then input to active filter IC101B (pin 2) where noise signals are selected at approximately 20kHz then output from pin 1.

The noise signals are rectified by D110 and are then converted to DC voltage and used as squelch control signals. This voltage is input to IC703 (pin 15) on the LOGIC unit through inverter circuit Q119, and is then output from pin 30 as R.MUTE voltage.

R.MUTE voltage is applied to the gate of Q120 and switches AF output. Q120 also eliminates the noise from channel changing during operation. Q126 receives a strobe pulse from IC703 and applies a mute signal to Q120.

#### 3 - 1 - 6 FIRST LOCAL OSCILLATOR CIRCUIT

The signal (420 ~ 490MHz) generated at the VCO is amplified at Q202 on the PLL unit and is then input to gate 2 of Q502 on the RF unit through D203.

## 3 - 2 TRANSMITTER CIRCUITS

### 3 - 2 - 1 MIC AMPLIFIER CIRCUIT

The audio signal from MIC 1 or MIC 2 is amplified by a limiter amplifier circuit consisting of Q101 to Q104. This limiter amplifier circuit employs a negative feedback circuit that has pre-emphasis characteristics between 300Hz and 3kHz and 6dB/oct.

The first mic amplifier circuit consists of a differential amplifier circuit that makes a limiter output signal in a symmetrical wave form.

The output signal from the limiter amplifier is like a square wave and includes many RF signals which are fed back from the transmitter's final stage. The output signal, therefore, is fed to splatter filter circuit IC101A which reduces signals with more than 3kHz, and then applies it to the VCO for modulation.

### 3 - 2 - 2 BUFFER AMPLIFIER CIRCUIT

The 400MHz band is generated by the VCO and is buffered and amplified at Q202. Output from Q202 is amplified at pre-drive stage Q204 through D204 and is then amplified at drive stage Q205, thus obtaining a wideband of 150mW.

### 3 - 2 - 3 POWER AMPLIFIER CIRCUIT

IC201 is a small-sized power module giving a stable output power of more than 5W between 450 and 490MHz with a driving power of 150mW from Q205.

The driving signals from Q205 are fed into IC201 (pin 1), amplified up to approximately 5W at 13.2V, and are output from pin 5.

While transmitting, Q216, D208 and D209 are activated, then L209 and C246 become parallel resonance circuits. The output power from IC201 is applied to the antenna terminal through a low-pass filter consisting of C243, L211, C244, L212 and C245 that filters and reduces harmonic spurious radiation.

Q203 controls the bias voltage of Q204, Q205 and IC201 to prevent unwanted emissions when switching from receive mode to transmit mode, or when the PLL is being unlocked to prevent a possible failure.

### 3 - 2 - 4 APC CIRCUIT

The antenna mismatching detection circuit consists of L207, C234 to C239, D206, and D207. Output voltage of the detector is a minimum value when the antenna impedance is matched at 50 ohms. However, when the antenna impedance is in a mismatched condition, the detector voltage becomes higher than it would be if the antenna were matched.

Q214 and Q215 make up the differential amplifier circuit. At the base of Q215, the bias voltage determined by R262, R263, and R266 is applied.

The voltage detected at D206 and D207 is combined by R226 and R227, and is fed into the base of Q214. If a mismatched condition occurs, the voltage at the base of Q214 will be higher than at the base of Q215. This condition will reduce the Q214 collector current and the Q213 base current, decreasing the current of Q204 and Q205.

The output power of Q205 is also decreased, reducing the output power of IC201 until the base voltage of Q214 becomes equal to the base voltage of Q215.

In a matched condition, HIGH output power is determined by the value of R262. When the power switch is in the LOW position, the combination of R264 and R265 is connected in parallel with R263. R264 may then be used to set the low power.

## 3 - 3 PLL

The PLL is designed in a way that allows the desired frequency to be generated directly by the VCO, adopting a dual modulus pre-scaler system. The PLL consists of a pre-scaler (IC202) and PLL IC (IC203). It is fed "divided by N-DATA" from the MPU which determines the operating frequency.

N-data is determined by dividing the desired frequency by the reference frequency. Desired frequency is the transmit frequency in the transmit mode and the first local oscillator frequency in the receive mode.

$$N = \frac{\text{Desired frequency}}{\text{Reference frequency}}$$

A reference frequency of 12.5kHz is obtained by oscillator Q120, X101 and the internal IC106 divider.

Signals from the VCO that are buffer amplified at Q206 are divided N times at IC202 and fed into pin 4 of IC203. Signals inside IC203 are phase detected and are lock voltages that are output from pins 12 and 13. Output voltages are applied to varactor diode D401 in the VCO unit through a loop filter that controls the VCO frequency. Due to a no-multiplying mixing circuitry, the circuit constitution is simple and reduces spuriousness.

### 3 - 3 - 1 UNLOCK CIRCUIT

When the PLL is unlocked, pin 10 of IC203 is at a LOW voltage level. This voltage is fed into unlock detection circuits Q121 and Q124 on the MAIN unit and is then sent to the MPU on the LOGIC unit.

### 3 - 3 - 2 LOOP FILTER CIRCUIT

Output from pins 11 and 13 on the IC203 is fed into charge pumps Q208 and Q209 and is then applied to a lag lead-type loop filter that consists of R241, R243, and C267. These circuits determine the characteristics of the PLL.

Output voltage from loop filters control varactor diode D401 on the VCO unit through integral circuits R233 and C258. Q219 and Q220 are switching circuits that determine the time constant of the loop filters. These circuits shorten the time for lock up when changing from receive to transmit mode and vice versa.

### 3 - 3 - 3 VCO UNIT

The VCO, Q402 employs a Colpitts oscillator circuit. The VCO free-run frequency is shifted by induction reactance which is changed by Q401 and D402, and is then controlled by a varactor diode. Thus a stable oscillation is achieved over a wide frequency range.

While receiving, the RS5 line is 5V, Q401 is activated, and the VCO free-run frequency is shifted and controlled by a varactor diode. While transmitting, the RS5 line is 0V and Q401 turns OFF. D402 is a reverse bias and has a capacitance. D402 is connected in a series with C405 and C406, resulting in a VCO free-run frequency that is shifted higher than the receive frequency.

While transmitting, modulation signals are applied to the anode of D402, and then its capacitance is changed, performing frequency modulation. This deviation is adjusted by R186.

## 3 - 4 POWER SUPPLY CIRCUITS

### 3 - 4 - 1 INTERNAL/EXTERNAL POWER

When using a battery pack, RL101 is OFF. When a power source having 10 ~ 16V is connected to the external power terminal (EXT), RL101 will be activated. The power switch will then be connected to an external power source.

If an incorrect connection to the external power terminal (such as reversing polarities) is made, D119 will be affected, reversing its bias and preventing RL101 from being activated.

### 3 - 4 - 2 +5V REGULATOR CIRCUIT

The +5V voltage regulator circuit consists of Q117, Q118 and D107 where output voltage is kept at 5V constantly, even with input voltage from 5.1 ~ 16V. These transistors are connected in a complementary circuit in order to acquire a higher current amplification factor. As the temperature coefficient of the junction voltage of D108 is nearly equal to the voltage of Q117  $V_{BE}$ , the output voltage is kept constant against temperature changes.

### 3 - 4 - 3 5V REGULATOR, POWER SAVE CIRCUIT

This voltage regulator circuit uses reference voltage from pin 29 of IC703 on the LOGIC unit. This circuit consists of Q115 and Q116 which are also connected in a complementary circuit in order to stabilize operations.

When the power save function is activated, power save signals from pin 29 of IC703 on the LOGIC unit are applied to Q115 at intervals, thus Q115 turns ON and OFF alternately. The result is that the power save signal controls +5V and constructs the POWER SAVER.

### 3 - 4 - 4 T/R SWITCHING CIRCUIT

While transmitting, Q106 is activated and transfers transmit signals to the MPU. At the same time, Q107, Q108, and Q109 are also activated, and Q110 turns OFF. Q113 and Q114 are T5 voltage regulator circuits that are switched by Q109. When Q109 is activated, the T5 line operates at 5V and the R5 line at 0V. While receiving, Q106 is OFF. Q109 is then OFF and Q110 is ON, resulting in the T5 line being 0V and the R5 line 5V.

When the squelch is changed from the closed to open condition some noise will be emitted from the speaker. This phenomenon is called the squelch burst. To remove this noise from the speaker, the squelch can be controlled by a CTCSS tone.

The transmitter contains a delay circuit for the transmit carrier. The delay period for the transmit carrier is longer than that of the PTT.

In this transceiver the delay circuit consists of time constants C131 and R137 which remove the squelch burst.

### 3 - 4 - 5 VOX POWER SOURCE CIRCUIT

This is a current limiter that supplies a voltage to the external VOX unit, HS-10SA. Current drain of up to 5mA is acceptable. In the case of a normal load current the voltage drop through R273 is small, approximately 5V, and is fed into the VOX unit. The increase in load current leads to the increase of the voltage drop at R273. When the voltage, obtained by adding the voltage between the emitter and base of Q217 to it, is equal to the voltage between R272 and the D216 cathode, the load current is limited.

This VOX power source circuit is also a data transmit circuit when the cloning operation is activated. The base of Q217 connects through R272 to pin 28 (CPO) on IC703. CPO is the output port for cloning data and controls Q217, thus data is transferred to existence.

Cloning data exits from the mic terminal and passes through R102, R104, and control Q106 on the MAIN unit. It then enters pin 14 (SEND) of IC703 for data reception. SEND also combines a data input port.

## 3 - 5 LOGIC CIRCUITS

The LOGIC circuits consist of an 8 bit C-MOS MPU, a 2K C-MOS RAM, a CTCSS tone encoder/decoder, and an LCD driver. They control frequency, tone, display, etc.



### 3 - 5 - 1 MPU

This MPU,  $\mu$ PD78C06AG, includes a 4K byte ROM and a 128 byte RAM. Following is an explanation of operations related to each port.

#### (1) DB 0 ~ DB 7

These are bi-directional ports, and are an 8 bit data bus. The bus transfers or receives the data to and from a 2K RAM IC chip. DB 0 to DB 3 are also used for matrix reception.

#### (2) PE 0 ~ PE 15

These are 16 bit ports which have address ports and output ports that are switched by the program. PE 15 is used to select signals. PE 0 to PE 10 generate address signals. PE 0 to PE 3 and PE 14 are output ports for the matrix. PE 0 is used as a switching signal for command and LCD driver data. (The matrix construction is described in Fig. 3-1.)

#### (3) PORTS A

These are output ports with an 8 bit latch.

- PA 7 ( $\overline{CS}$ )

This is an enable signal for the LCD driver. When this port is LOW, the MPU transfers COMMAND or DATA to the LCD. (Timing charts is described in Fig. 3-2.)

- PA 4 (TMUT)

This is an output port and will be at the HIGH level position for approximately 60 milliseconds when changing from receive to transmit. If the PLL is unlocked then this port will remain at a HIGH level.

- PA 3 (RMUT)

This port will be at the HIGH level position when receiving in the mute condition.

- PA 2 (PSAU)

This port outputs control signals for saving power. When this port is in the LOW level position, the transceiver is in the save condition.

- PA 1 (CPO)

This port outputs cloning data.

(The cloning data construction is described in Fig. 3-3.)

- PA 0 (STRB)

This port outputs latch signals for PLL data.

#### (4) PORTS B

These ports are 8 bit bi-directional ports that change in 1 bit steps.

- PB 7 ( $\overline{MONI}$ )

This is an input port for the monitor switch.

- PB 6 ( $\overline{T/R}$ )

This is an output port for switching the signals of the TONE IC. While in the transmit mode, this port is at the LOW level position; in the receive mode it is in the HIGH level position. However, if the TONE number is 0, voltage signals are opposite.

- PB 0 ~ 5 (S0 ~ S5)

These are output ports for TONE data which describe TONE numbers, frequency, and data.

#### (5) PORTS C

These are input ports with 6 bits of data.

- PC 5 ( $\overline{BUSY}$ )

This is an input port for BUSY signals from the LCD driver.

- PC 4 (TRF)

This is a T5V input port. When this port is at the HIGH level position the TX indicator is illuminated.

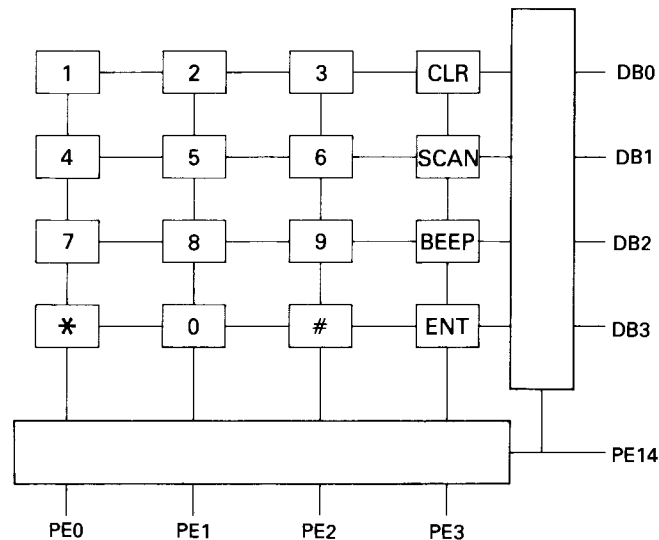
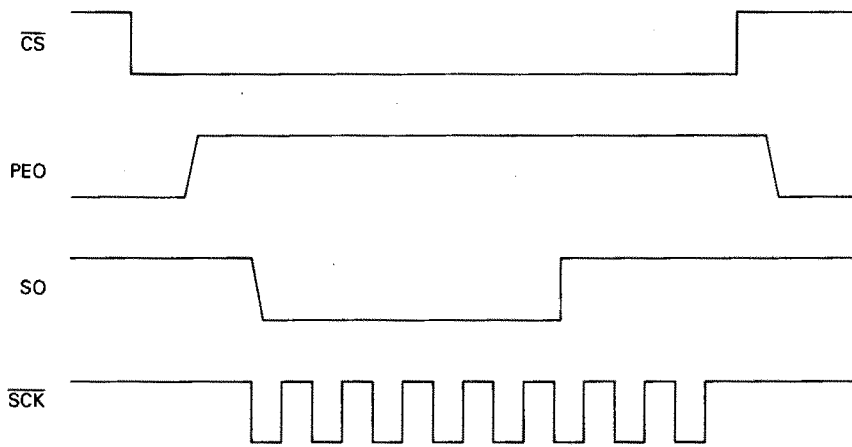

Fig. 3-1 Matrix Construction

AT COMMAND TRANSMITTING (CODE 0E, 0H)



AT DATA TRANSMITTING (DATA 0A, 5H)

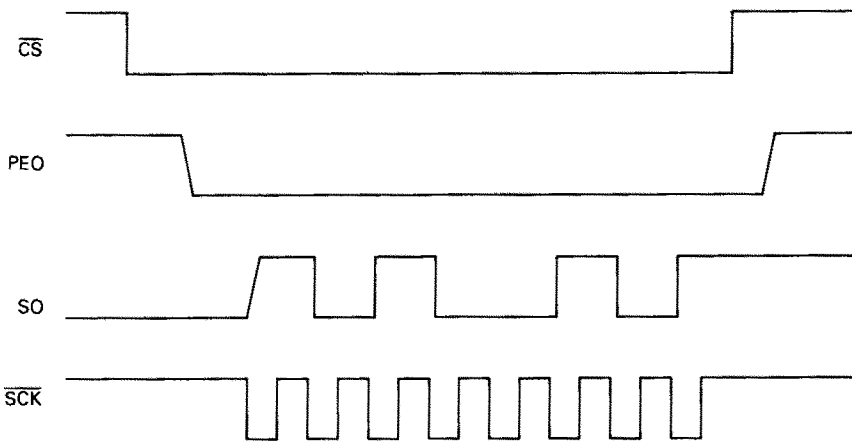

Fig. 3-2 Timing Chart of COMMAND and DATA

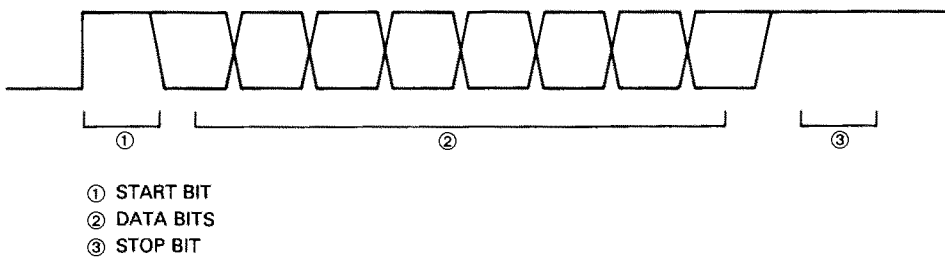

Fig. 3-3 Cloning Data Construction

- **PC 3 ( $\overline{\text{FUNC}}$ )**

This is an input port of the function switch. When the function key is pressed, this port is at the LOW level position and the secondary functions of the keyboard can be selected.

When this port is in the LOW level position while power switched ON, the MPU is in the receive mode of cloning.

- **PC 2 ( $\overline{\text{SEND}}$ )**

This is a T/R switching signal input port. When this port is in the HIGH position the MPU is in transmit mode. The port is also used to input cloning signals.

- **PC 1 ( $\overline{\text{SQL}}$ )**

This is an input port for squelch signals. When the squelch is open, this port is in the HIGH level position.

- **PC 0 ( $\overline{\text{UNLK}}$ )**

This is an input port for unlocked signals. When the PLL is unlocked, this port is at a LOW level position.

**(5) SERIAL PORTS**

- **SO**

This is an output port of the shift register inside the MPU. It outputs N-data, LCD commands, and LCD data.

- **$\overline{\text{SCK}}$**

This port outputs timing signals of data for transfer to the SO port. SO is altered by the trailing edge of the  $\overline{\text{SCK}}$  signal.

**(6) OTHERS PORTS**

- **INT 0**

This is an input port for detector signals of the TONE IC. When this port is at the HIGH level position the CALL indicator is illuminated.

- **INT 1**

This is an input port for stand-by signals. When the power switch is OFF this port is in the HIGH level position. The LCD then is not illuminated and each port is initialized.

- **TO**

This port outputs a BEEP sound.

- **$\overline{\text{RD}}$**

This port outputs timing signals when the MPU receives data (reading) to the RAM IC chip.

- **$\overline{\text{WR}}$**

This port outputs timing signals when the MPU transfers data from (writing) the RAM IC chip.

**3 - 5 - 2 RAM**

$\mu\text{PD446C}$  is a 2048 word 8 bit C-MOS RAM IC chip. This RAM memorizes operating channels, PLL T/R N-data, TONE numbers, shift frequencies, TONE-data tables, etc. The data are written or read to addresses which are selected by PE 0 to PE 10 of the MPU. Writing and reading timing depend on ports  $\overline{\text{RD}}$  and  $\overline{\text{WR}}$ .

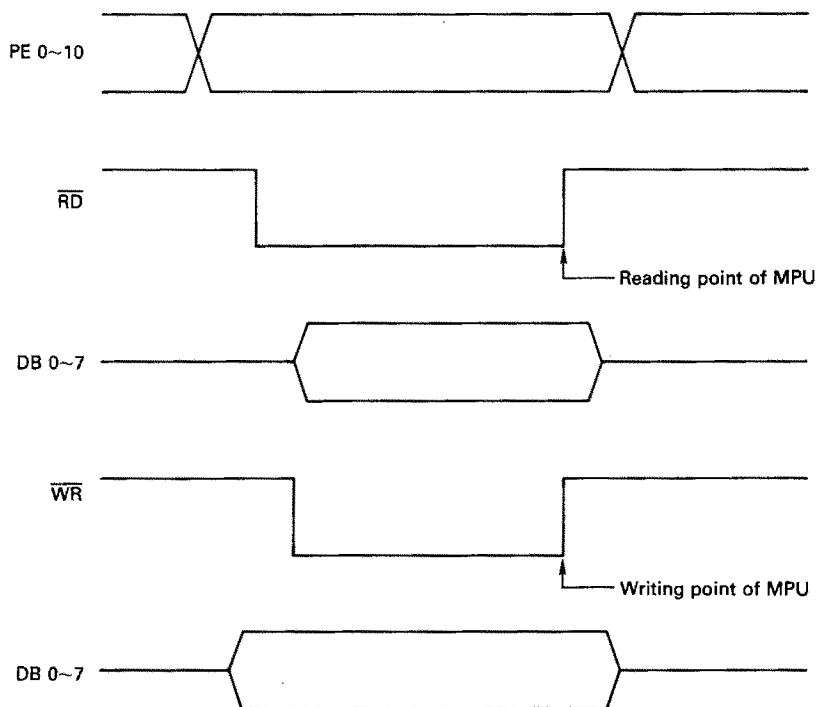

Fig. 3-4 Timing Chart of Memory Reading/Writing

### 3 - 5 - 3 RESET CIRCUIT

After the circuit is switched ON, the +5V line becomes 5V and Q703 is activated. The collector of Q703 thus is at the HIGH level position. Pin 12 of IC704E is in the LOW level position and pin 10 of IC704D is changed from LOW level to HIGH. The result is that the MPU and the LCD driver are reset.

At the time the power switch is turned off, Q703 also is OFF. Pin 12 of IC704E then is in the HIGH position and is applied to INT 1 of the MPU, resulting the MPU becomes stand-by operate.

### 3 - 5 - 4 DISPLAY CIRCUIT

IC602, in the DISPLAY unit is the LCD driver, and segments on the LCD are displayed with 1/2 bias and 1/2 duty conditions. The bias voltage is generated via the dividing resistor which consists of R605, R606 and R607. Output from CM1, CM2, and S0 to S31 on the IC601 drive the LCD segments.

### 3 - 5 - 5 DTMF CIRCUIT

IC602, the DTMF encoder, generates tone signals that match DTMF telephone dialing tones. While transmitting, Q704 will be activated, thus sending voltage to IC602 and to the CONT of IC603.

When there is input from the keyboard, the proper frequency dividing ratio which divides X601 is selected to output a set of audio frequencies.

### 3 - 5 - 6 CTCSS CIRCUIT

IC706 generates 37-type tones of programmable CTCSS encoder/decoder. When a tone number is set, data is sent to encoder/decoder. When a tone number is set, data is sent to IC706 from the MPU (S0 ~ S5). The  $\bar{T}/R$  port is a switching port for transmitting and receiving for IC706. When this port is in the LOW position, IC706 is in the transmit mode, and when the port is in the HIGH position IC706 is in the receive mode. However, while transmitting with tone number 0, the  $\bar{T}/R$  port of IC703 is in the HIGH position, and thus no tone signal is output from IC706.

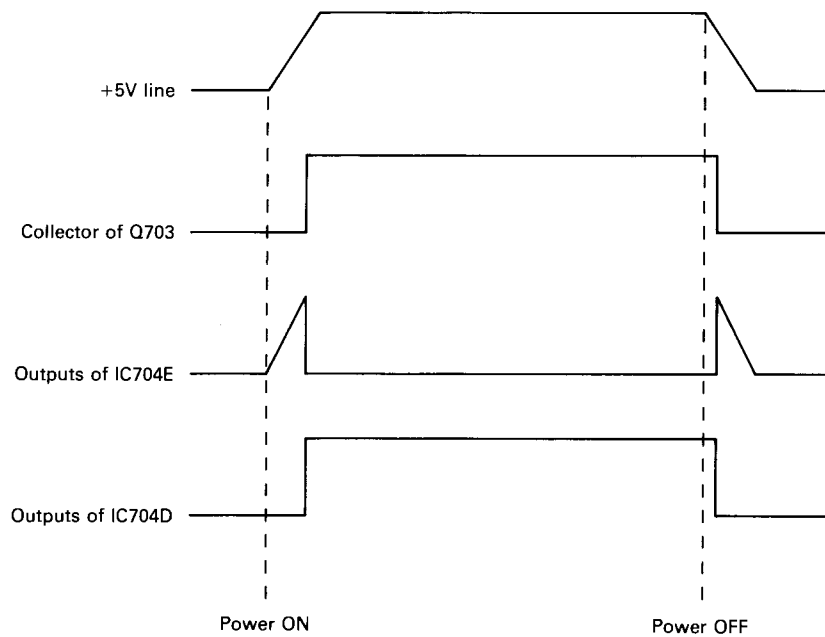
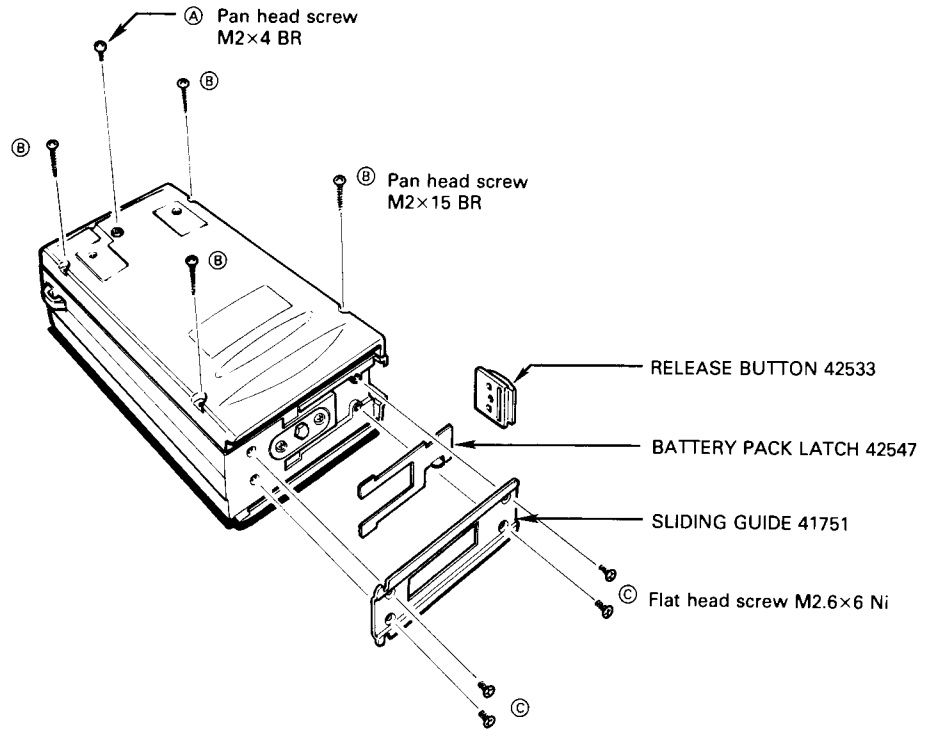

Fig. 3-5 Reset Timing Chart

## SECTION 4 MECHANICAL PARTS AND DISASSEMBLY

### 4 - 1 DISASSEMBLY OF THE CASE

1. Turn the power switch off and removed the power pack.
2. Remove screw (A) and four screws (B) on the rear panel, and four screws (C) on the bottom as shown in the figure.



3. Remove the rear panel as shown in the figure.

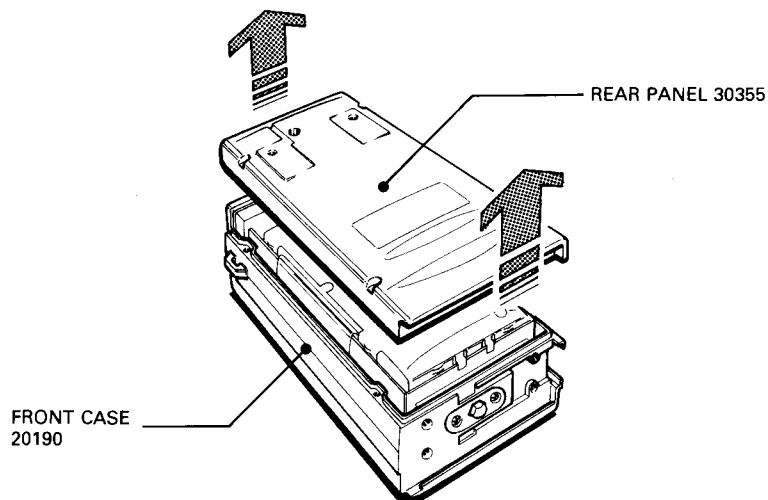

- Slide the inner frame upward slightly as shown in the figure, and lift the frame away from the front cover. At this time, be sure not to damage the flexible board.

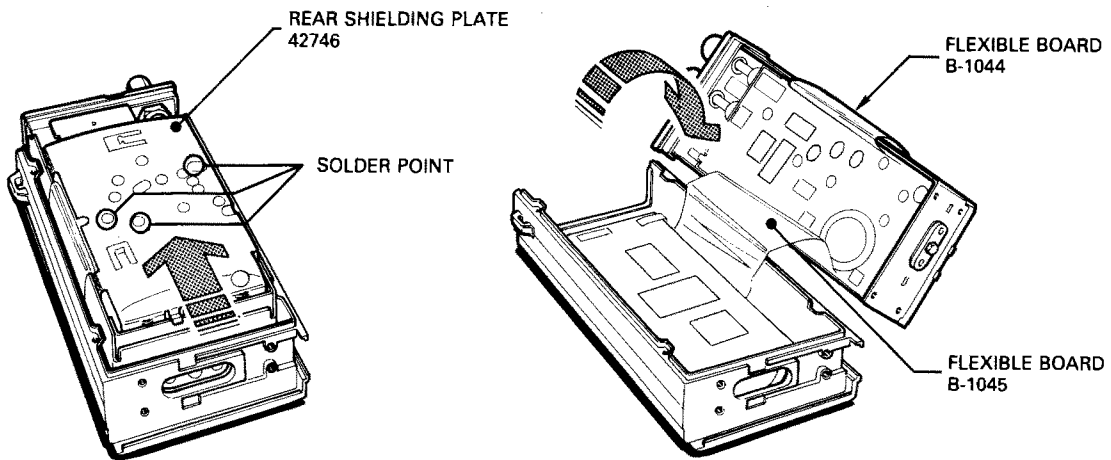

- To see the printed sides of the MAIN and PLL boards, remove the SQUELCH and VOLUME CONTROL/POWER SWITCH knobs. Remove the four screws on the sides of the inner frame.

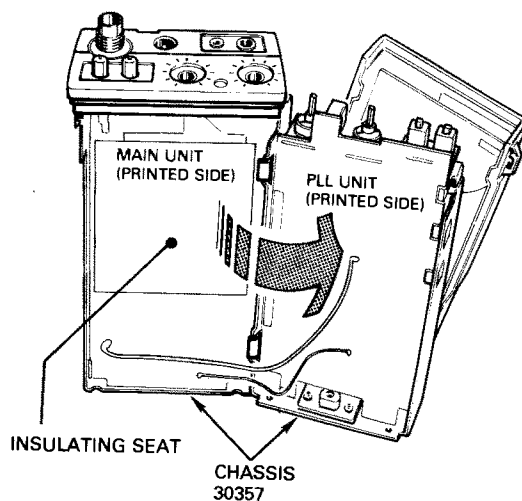
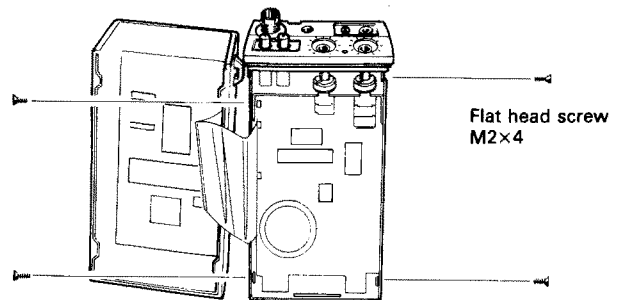
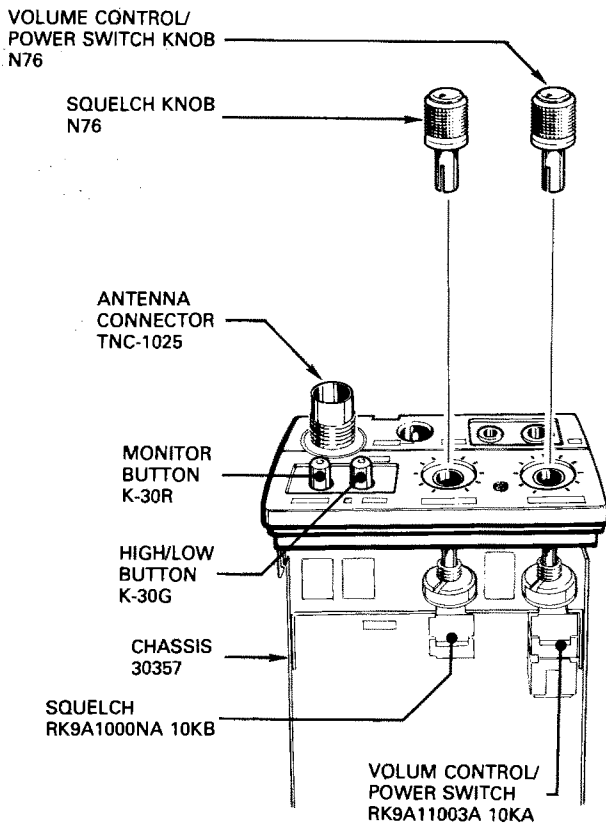

## 4 - 2 DISASSEMBLY OF THE TOP PANEL

1. Remove screw (A).
2. Remove the TNC-NUT and the TNC-WASHER.
3. Remove the ANTENNA CONNECTOR by desoldering point (B) on the parts side and point (C) on the printed side of the PLL board.
4. Remove the TOP PANEL by slightly prying outward on both sides points (D) of the TOP PANEL. See the diagram below. Be careful not to break the tabs.

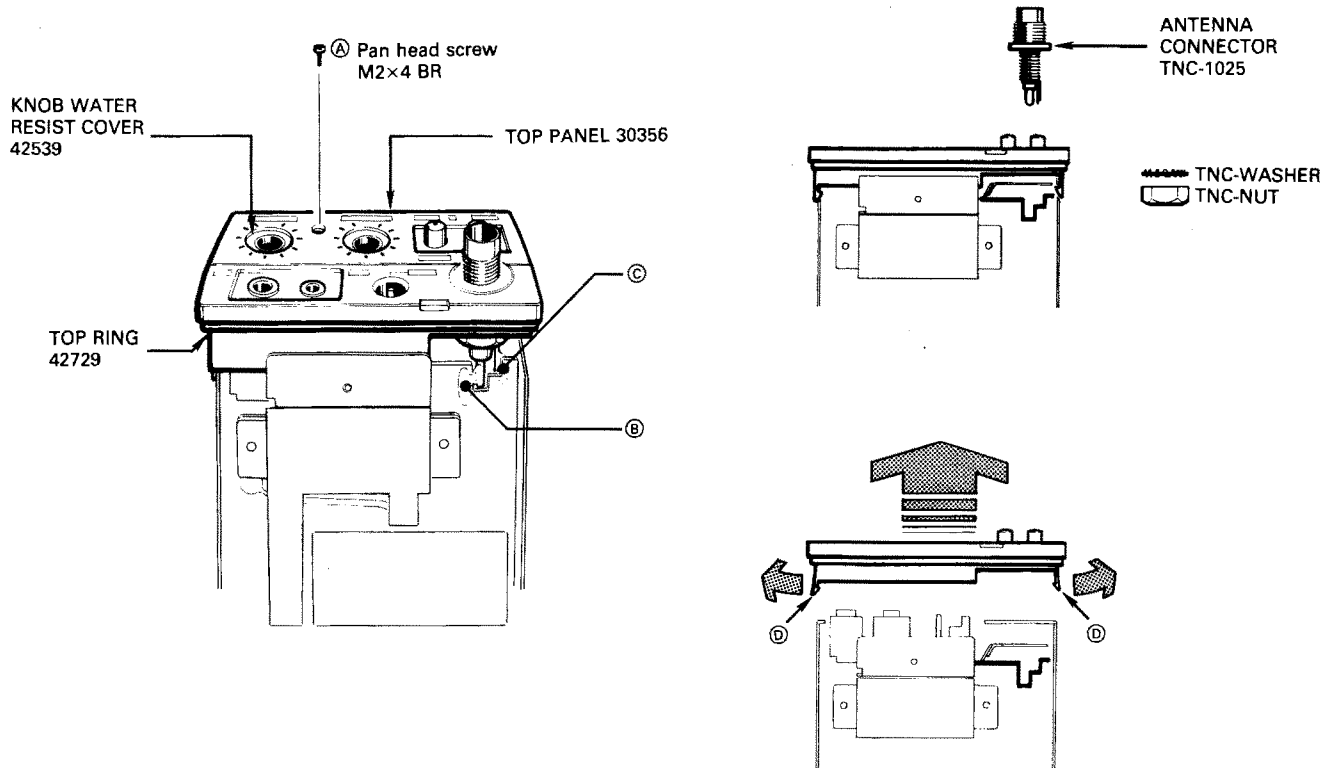

## 4 - 3 PA/EXTERNAL JACK ASSEMBLY (HOW TO REPLACE THE POWER MODULE)

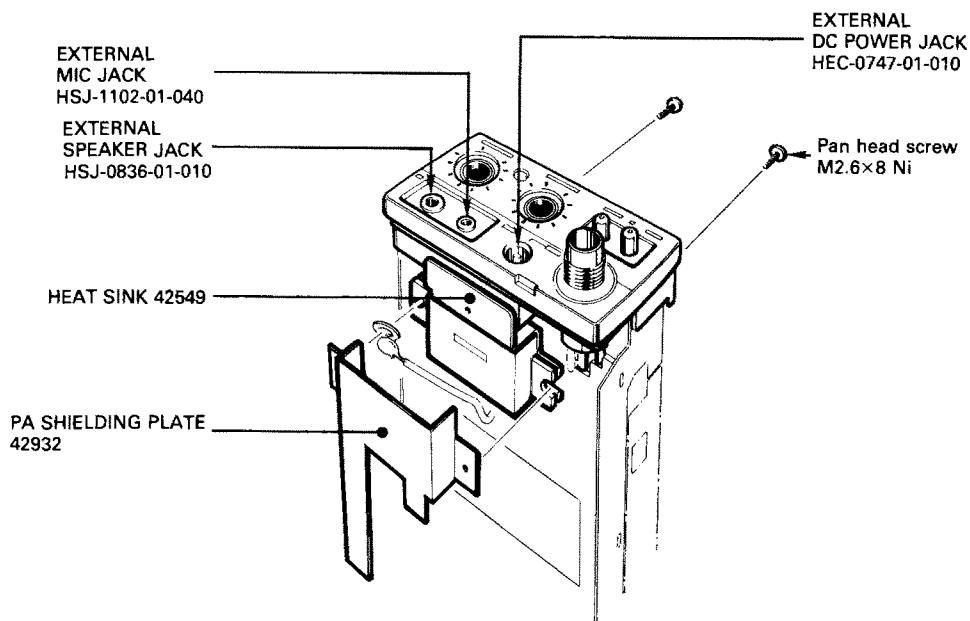

#### 4 - 4 SPEAKER/MICROPHONE ASSEMBLY (HOW TO REPLACE THE SPEAKER/MICROPHONE)

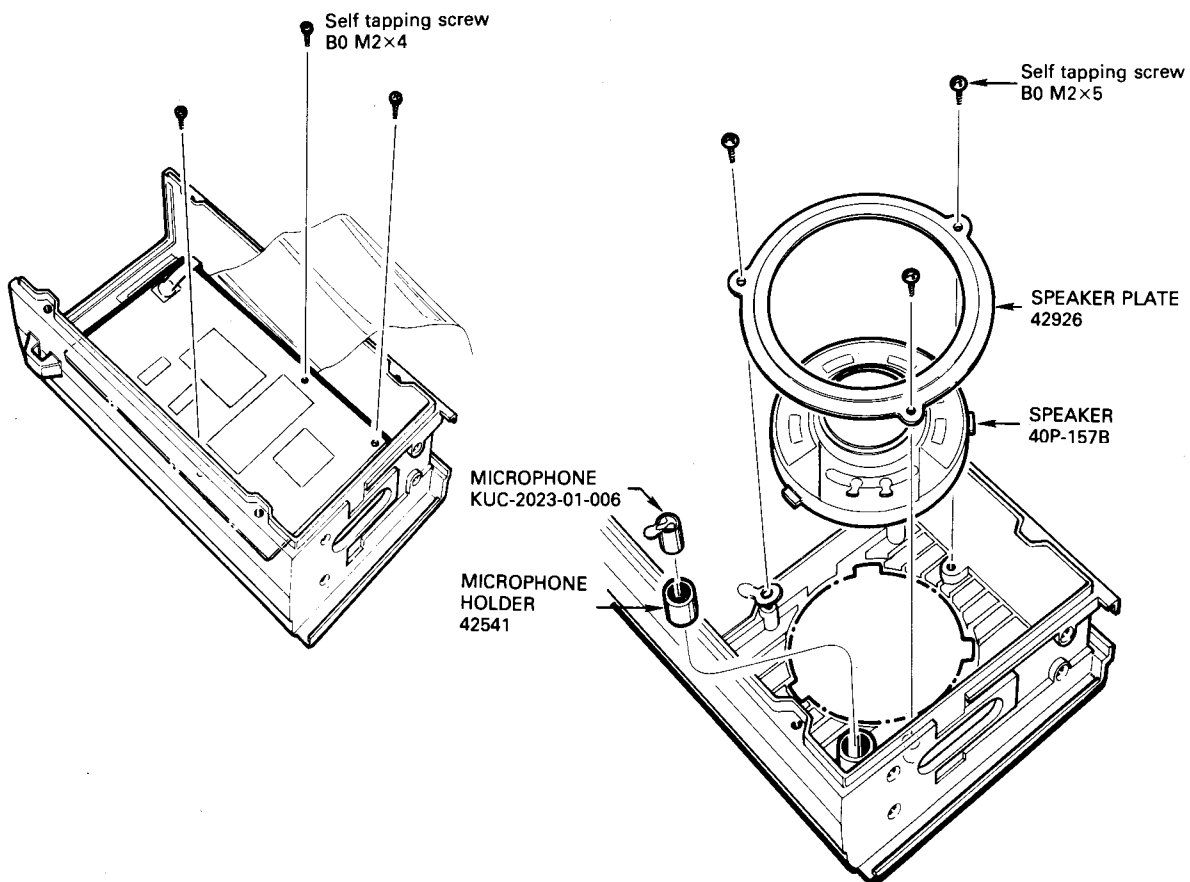

#### 4 - 5 PTT SPRING ASSEMBLY (HOW TO REPLACE PTT SPRING)

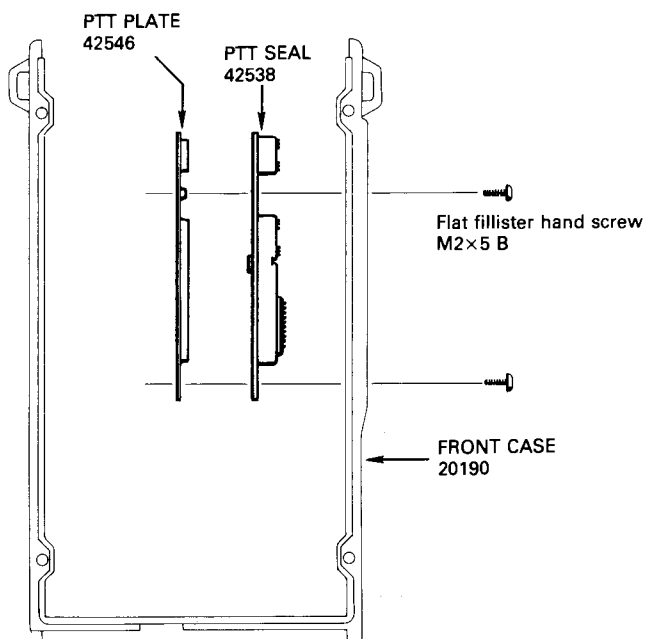



# 4 - 6 UNIT BOTTOM ASSEMBLY

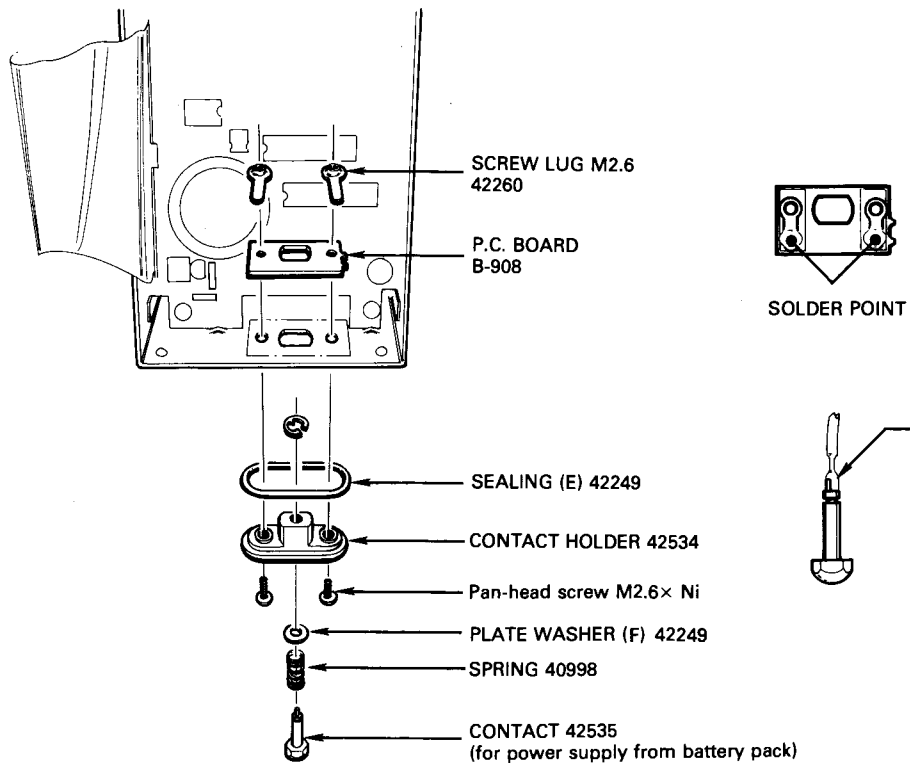

## SECTION 5 ADJUSTMENT PROCEDURES

### 5-1 PREPARATION BEFORE SERVICING

#### ■ REQUIRED TEST EQUIPMENT

EQUIPMENT	GRADE AND RANGE	EQUIPMENT	GRADE AND RANGE
DC power supply	Output voltage : 13.2 V DC Current capacity : 2 A or more	DC voltmeter	Input impedance : 50 k $\Omega$ /DC or better
RF power meter (Terminated type)	Measuring range : 0~5 W Frequency range : 0.1~520 MHz Impedance : 50 $\Omega$ SWR : Less than 1.2 : 1	AC milli-voltmeter	Measuring range : 10 mV~10 V
Frequency counter	Frequency range : 0.1~520 MHz Frequency accuracy: $\pm 1$ ppm or better Sensitivity : 100 mV or better	External speaker	Impedance : 8 $\Omega$
RF voltmeter	Frequency range : 0.1~520 MHz Measuring range : 0.01~10 V	Audio generator (AG)	Frequency range : 300~3000Hz Output level : 1~500 mV
Standard signal generator (SSG)	Frequency range : 400~520 MHz Output level : -127~-17 dBm (0.1 $\mu$ V~32 mV)	Attenuator	Power attenuation : 40 or 50 dB Capacity : 5 W or more
Oscilloscope	Frequency range : DC~20 MHz Measuring range : 0.01~10 V	Distortion meter	Frequency range : 1 kHz $\pm$ 10 Hz Measuring range : 1%~100%
		FM deviation meter	Frequency minimum: 520 MHz Measuring range : 0~ $\pm$ 10 kHz

CW : clockwise    CCW : counterclockwise    CP : check point

#### ■ CONNECTION

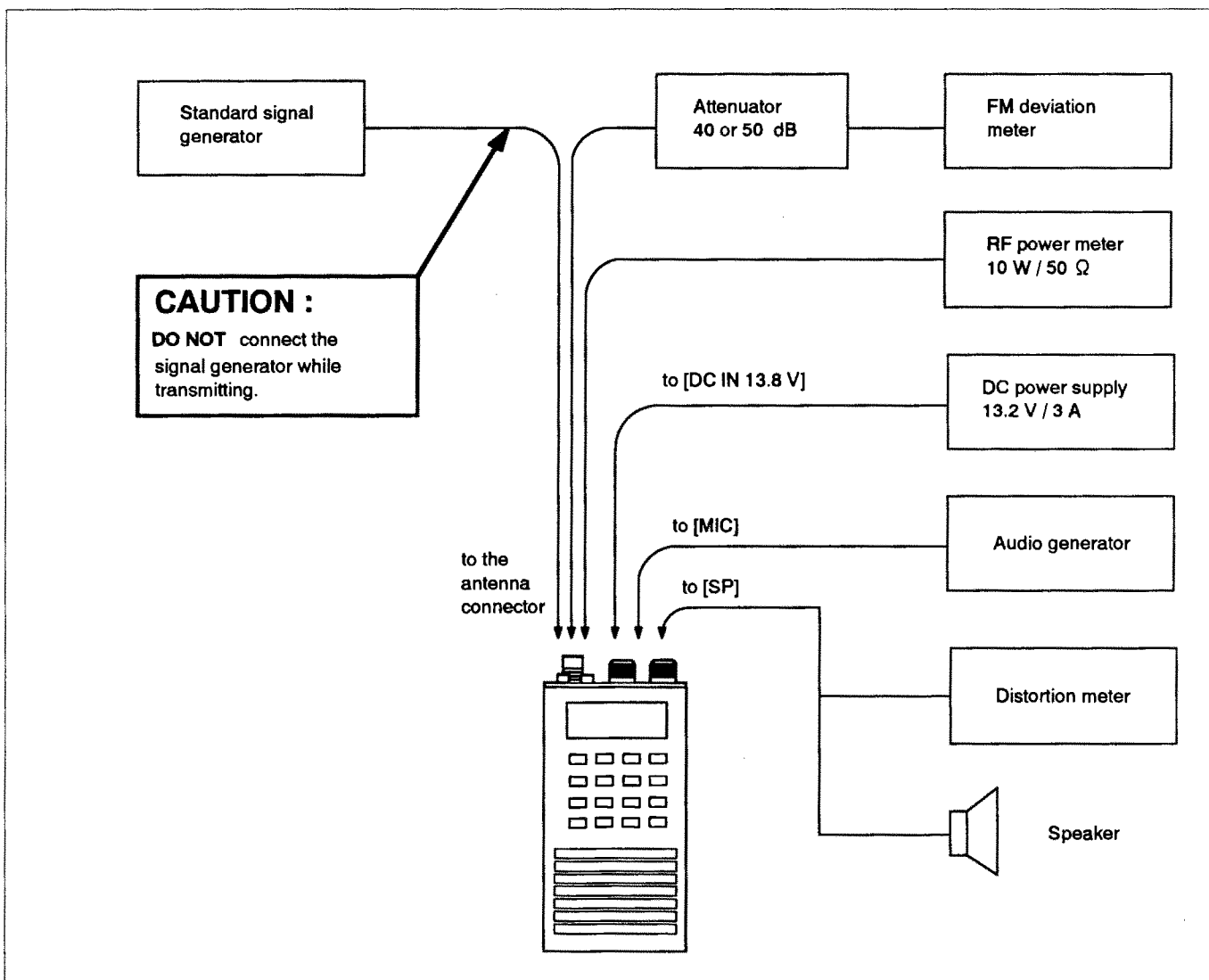

## 5-2 PLL ADJUSTMENT

ADJUSTMENT	ADJUSTMENT CONDITIONS	MEASUREMENT		VALUE	ADJUSTMENT POINT		
		UNIT	LOCATION		UNIT	ADJUST	
LOCK VOLTAGE	1	<ul style="list-style-type: none"> <li>Operating frequency : 400.000 MHz (USA-1, SWE) 420.000 MHz (UK) 450.000 MHz (USA, AUS) 480.000 MHz (USA-2)</li> <li>[HIGH/LOW] switch : LOW</li> <li>Transmitting</li> </ul>	PLL	Connect the DC voltmeter to the R282.	2.0 V (USA-1, SWE) 1.5 V (UK) 3.0 V (USA, AUS) 2.5 V (USA-2)	VCO	C402
	2	<ul style="list-style-type: none"> <li>Receiving</li> </ul>			3.0 V (USA-1, SWE) 1.5 V (UK) 3.0 V (USA, AUS) 4.0 V (USA-2)	VCO	C405
	3	Repeat steps 1-2 several times.					
	4	<ul style="list-style-type: none"> <li>Operating frequency : 430.000 MHz (USA-1, SWE) 470.000 MHz (UK) 490.000 MHz (USA, AUS) 512.000 MHz (USA-2)</li> <li>Receiving</li> </ul>	PLL	Connect the DC voltmeter to the R282.	Less than 11 V (USA-1, USA-2, SWE) 10-11 V (UK) 9-10 V (USA, AUS)		Verify
	5	<ul style="list-style-type: none"> <li>Transmitting</li> </ul>			Less than 11.0 V (USA, AUS) Less than 11.5 V (UK, USA-1, USA-2, SWE)		Verify
REFERENCE FREQUENCY	1	<ul style="list-style-type: none"> <li>Operating frequency : 415.000 MHz (USA-1, SWE) 470.000 MHz (USA, UK, AUS) 496.000 MHz (USA-2)</li> <li>Receiving</li> </ul>	PLL	Connect the frequency counter to the cathode of D203.	393.200 MHz (USA-1, SWE) 448.200 MHz (USA, UK, AUS) 474.200 MHz (USA-2)	PLL	C269
	2	<ul style="list-style-type: none"> <li>Operating frequency : 415.000 MHz (USA-1, SWE) 470.000 MHz (USA, UK, AUS) 496.000 MHz (USA-2)</li> <li>[HIGH/LOW] switch : HIGH</li> <li>Transmitting</li> </ul>		Loosely couple the frequency counter to the antenna connector.	415.000 MHz (USA-1, SWE) 470.000 MHz (USA, UK, AUS) 496.000 MHz (USA-2)		Verify

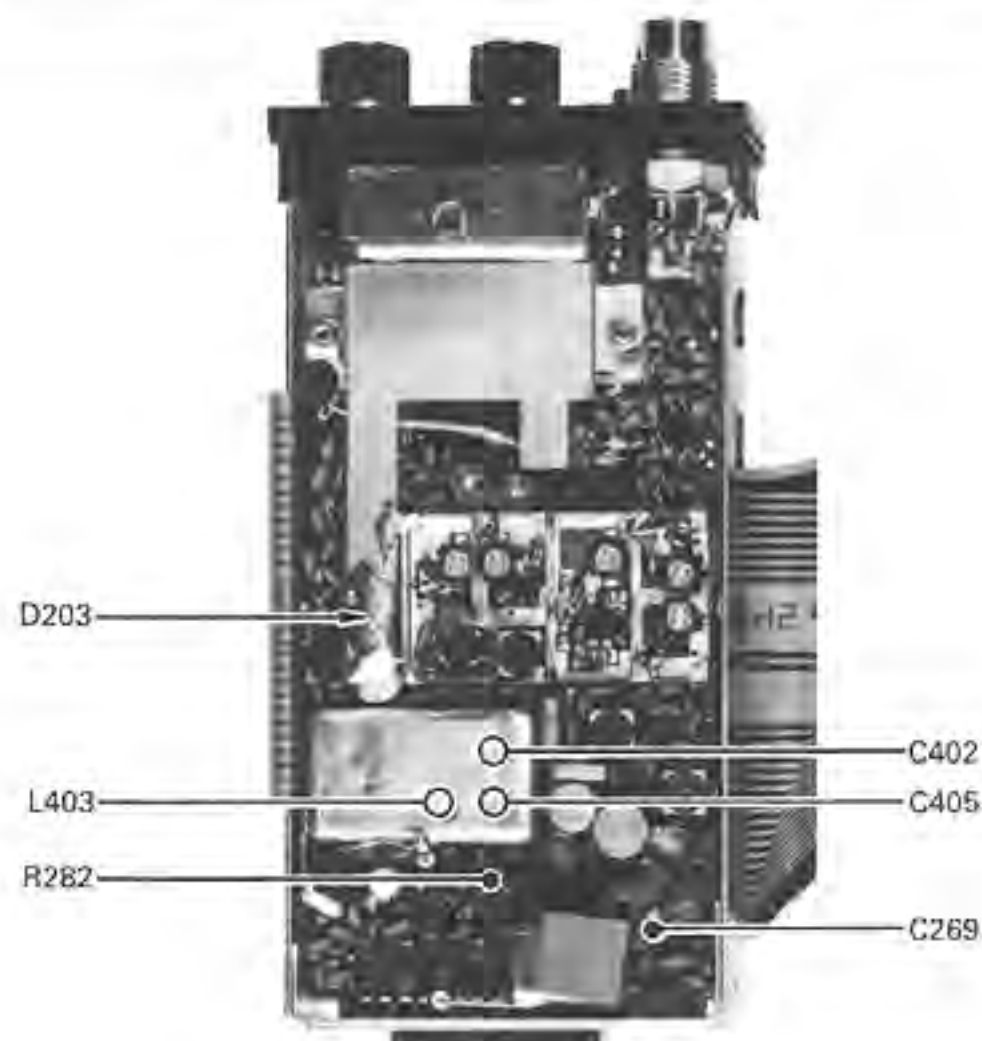

## 5-3 TRANSMITTER ADJUSTMENT

ADJUSTMENT	ADJUSTMENT CONDITIONS	MEASUREMENT		VALUE	ADJUSTMENT POINT	
		UNIT	LOCATION		UNIT	ADJUST
OUTPUT POWER	1 <ul style="list-style-type: none"> <li>Operating frequency : 415.000 MHz (USA-1, SWE) 470.000 MHz (USA, UK, AUS) 496.000 MHz (USA-2)</li> <li>[HIGH/LOW] switch : HIGH</li> <li>Transmitting</li> </ul>	Top panel	Connect the RF power meter to the antenna connector.	5 W	PLL	R262
	2 <ul style="list-style-type: none"> <li>[HIGH/LOW] switch : LOW</li> </ul>			0.5 W		R264
DEVIATION	1 <ul style="list-style-type: none"> <li>Operating frequency : 415.000 MHz (USA-1, SWE) 470.000 MHz (USA, UK, AUS) 496.000 MHz (USA-2)</li> <li>[HIGH/LOW] switch : HIGH</li> <li>Connect the audio generator to the [MIC] jack and set as : Level : 170 mV Modulation : 1 kHz</li> <li>Set the deviation meter as : HPF : 50 Hz LPF : 20 kHz De-emphasis : OFF Detector : p-p/2</li> <li>Transmitting</li> </ul>	Top panel	Connect the deviation meter to the antenna connector via the attenuator.	± 4.5 kHz (wide version) ± 2.1 kHz (narrow version)	MAIN	R186
	2 <ul style="list-style-type: none"> <li>Set the audio generator as : Level : 17 mV</li> <li>Transmitting</li> </ul>			± 3.5 kHz (wide version) ± 1.75 kHz (narrow version)		Verify
CTCSS DEVIATION	1 <ul style="list-style-type: none"> <li>Operating frequency : 415.000 MHz (USA-1, SWE) 470.000 MHz (USA, UK, AUS) 496.000 MHz (USA-2)</li> <li>Tone number : 01</li> <li>Apply no signal to the [MIC] jack</li> <li>Set the deviation meter as : HPF : OFF LPF : 20 kHz De-emphasis : OFF Detector : p-p/2</li> <li>Transmitting</li> </ul>	Top panel	Connect the deviation meter to the antenna connector via the attenuator.	± 0.75 kHz	MAIN	R115
DTMF DEVIATION	1 <ul style="list-style-type: none"> <li>Operating frequency : 415.000 MHz (USA-1, SWE) 470.000 MHz (USA, UK, AUS) 496.000 MHz (USA-2)</li> <li>Apply no signal to the [MIC] jack</li> <li>Set the deviation meter as : HPF : OFF LPF : 20 kHz De-emphasis : OFF Detector : p-p/2</li> <li>Push and hold [PTT] switch and then push the [ENT] key.</li> <li>Transmitting</li> </ul>	Top panel	Connect the deviation meter to the antenna connector via the attenuator.	± 3.5 kHz	MAIN	R112

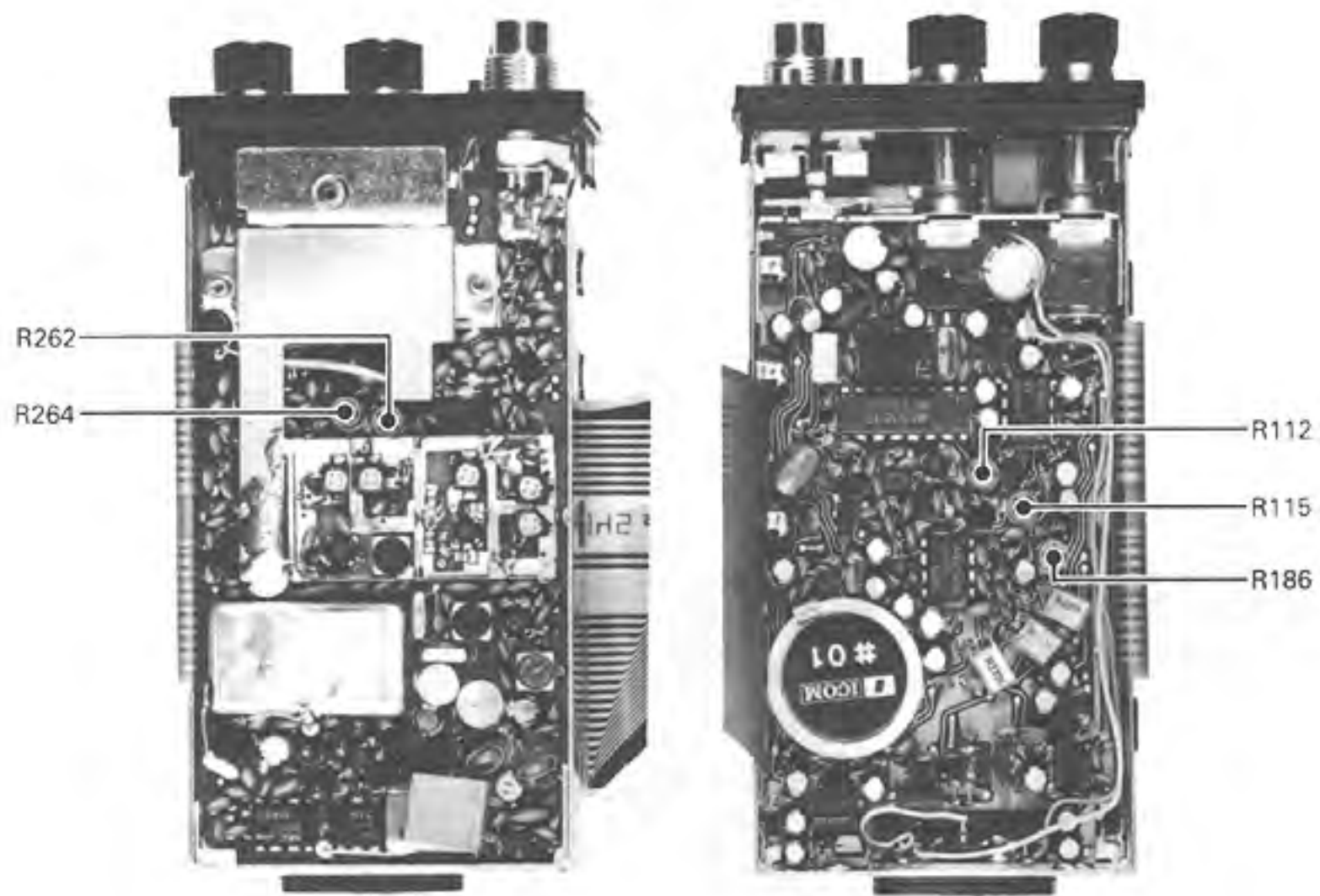

## 5-4 RECEIVER ADJUSTMENT

ADJUSTMENT	ADJUSTMENT CONDITIONS	MEASUREMENT		VALUE	ADJUSTMENT POINT	
		UNIT	LOCATION		UNIT	ADJUST
TOTAL GAIN	1 <ul style="list-style-type: none"> <li>• Operating frequency : 415.000 MHz (USA-1, SWE) 470.000 MHz (USA, UK, AUS) 496.000 MHz (USA-2)</li> <li>• [MONITOR] switch : ON</li> <li>• [SQL] control : Max. CCW</li> <li>• Connect the SSG to the antenna connector and set as : Level : 0.32 <math>\mu</math>V* Modulation : 1 kHz Deviation : 3.5 kHz</li> <li>• Receiving</li> </ul>	MAIN	Connect the RF voltmeter to IC102 (pin 16).	Maximum	PLL	L201 L202 L203
	2 <ul style="list-style-type: none"> <li>• Set the SSG as : Level : 0.32 <math>\mu</math>V*</li> </ul>	Top panel	Connect the distortion meter to the [MIC] jack with an 8 $\Omega$ load.	Minimum distortion	RF	Adjust in sequence C501 C504 C509 C512 C515

\* This output level of the standard signal generator (SSG) is indicated as SSG's open circuit.

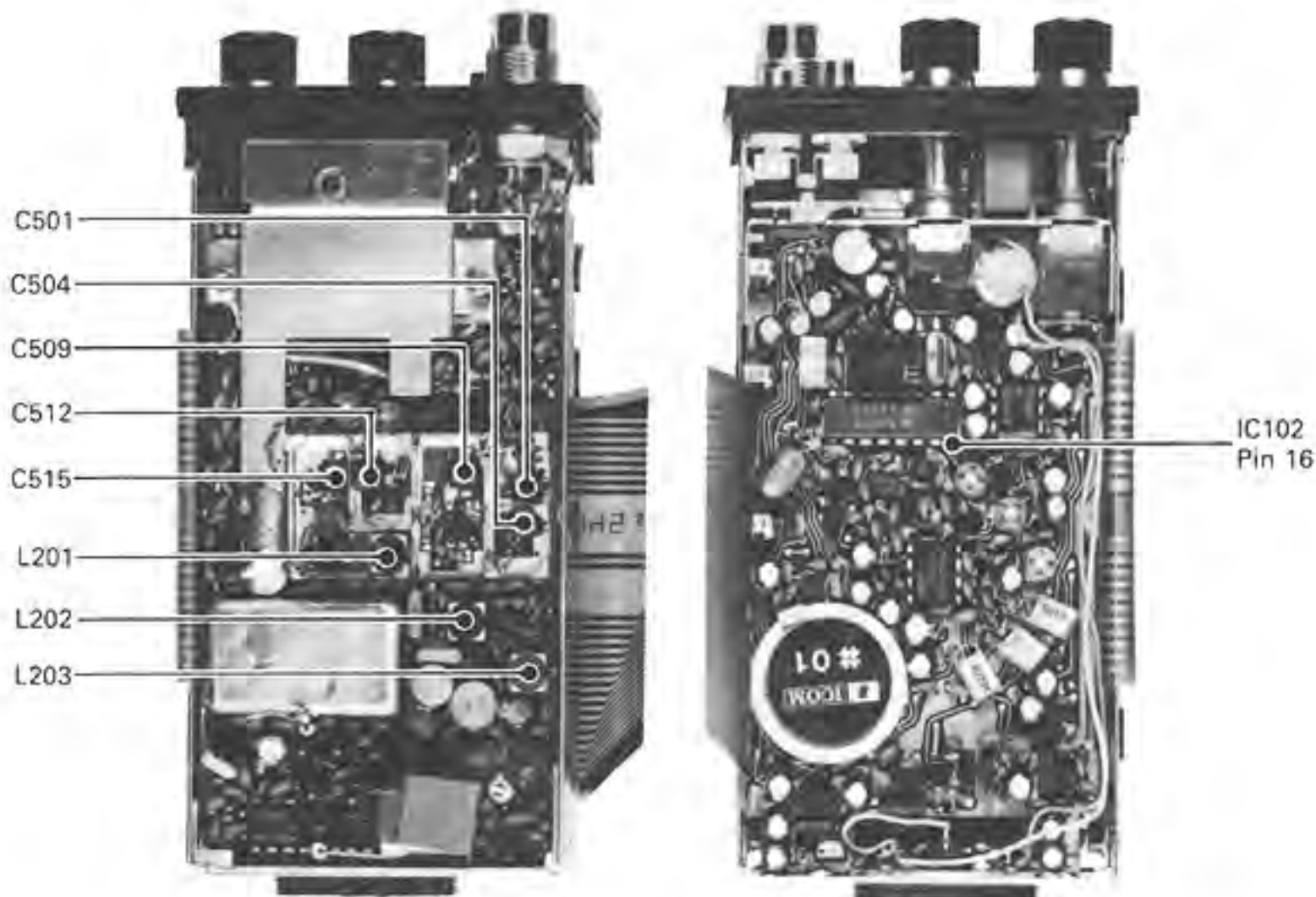

# SECTION 6 VOLTAGE DIAGRAMS

## MAIN UNIT VOLTAGE DIAGRAM

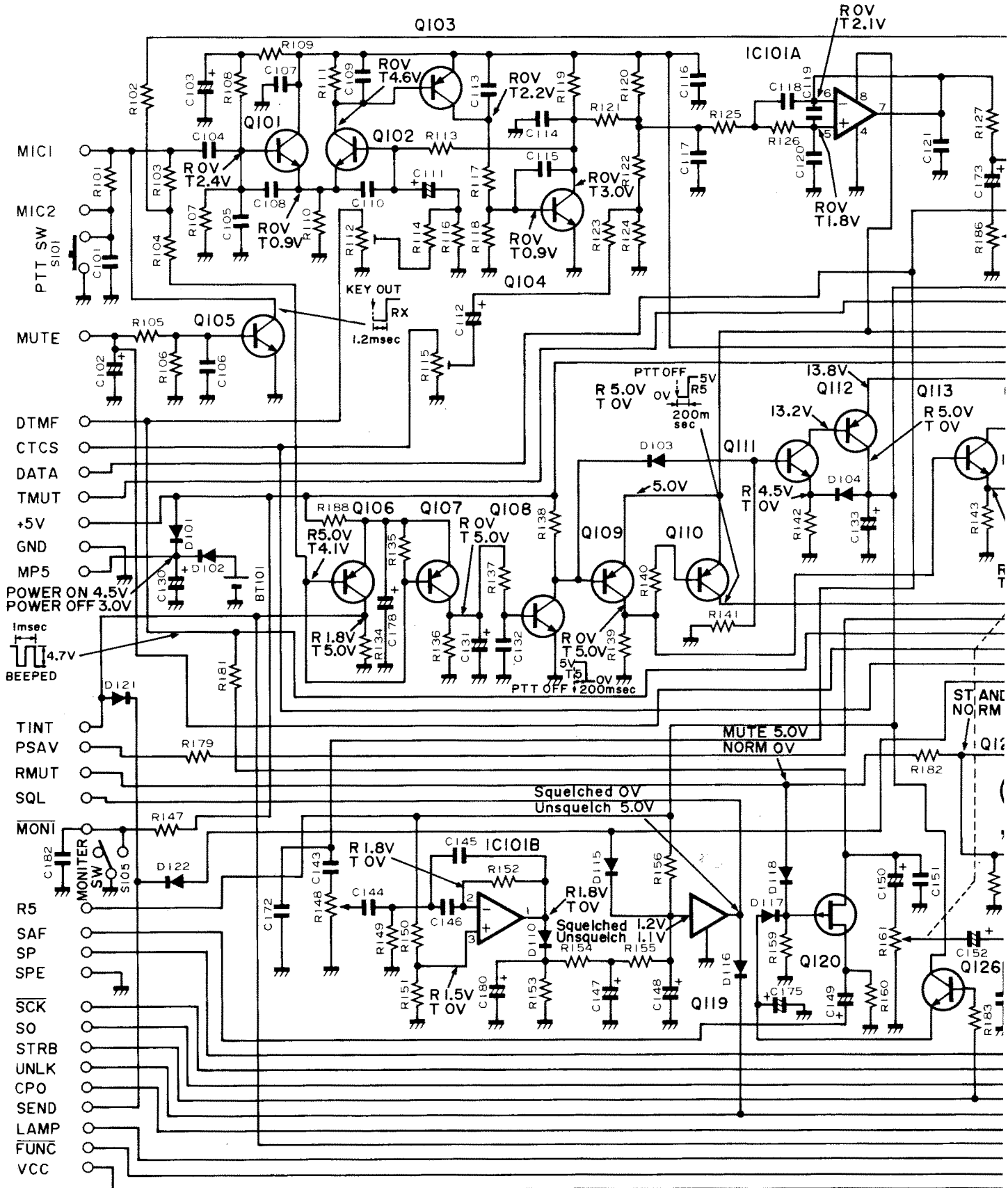



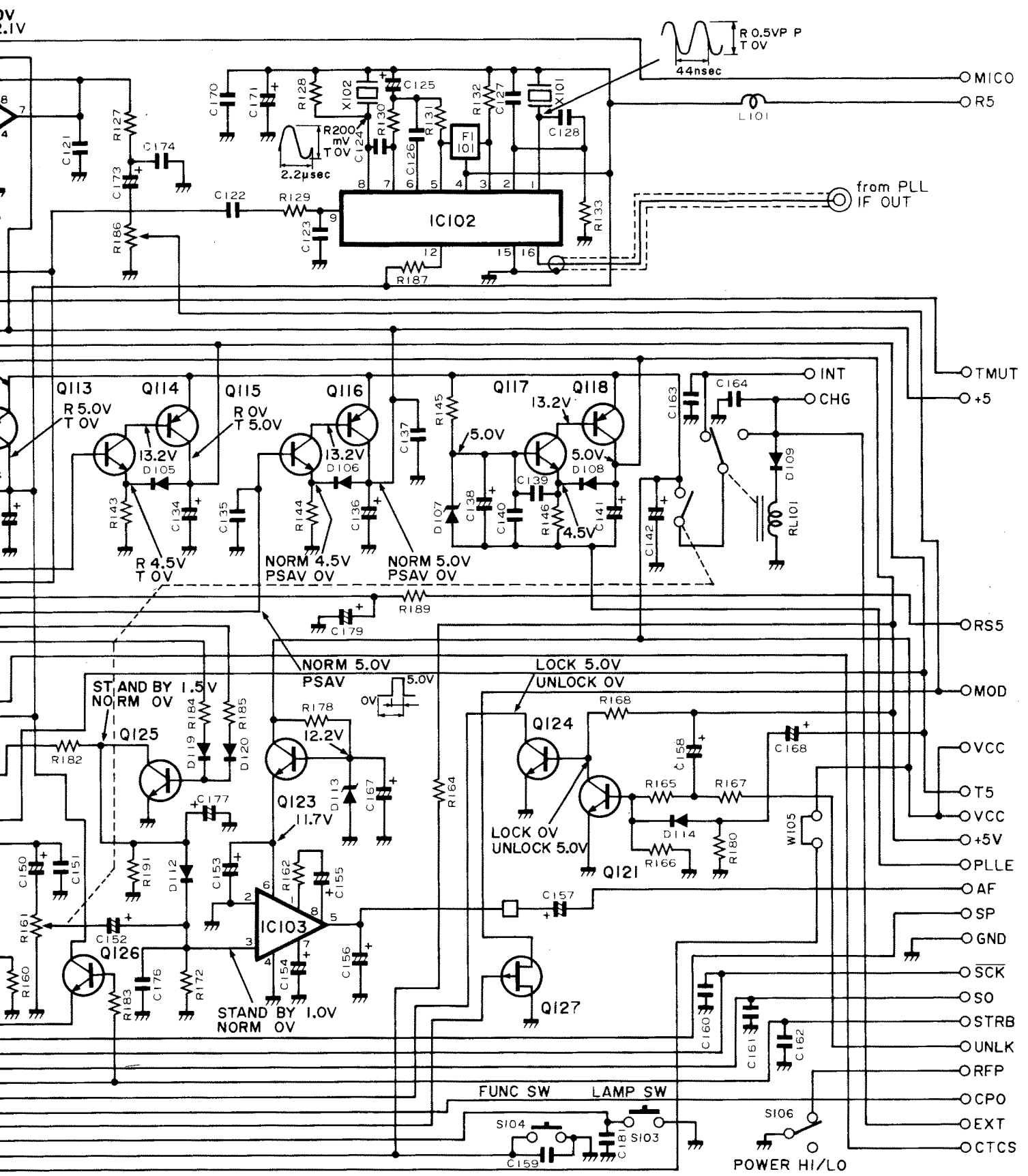



# PLL, VCO, RF UNIT VOLTAGE DIAGRAM

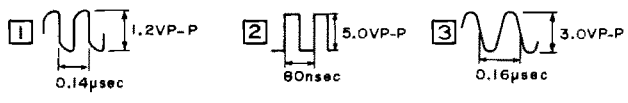
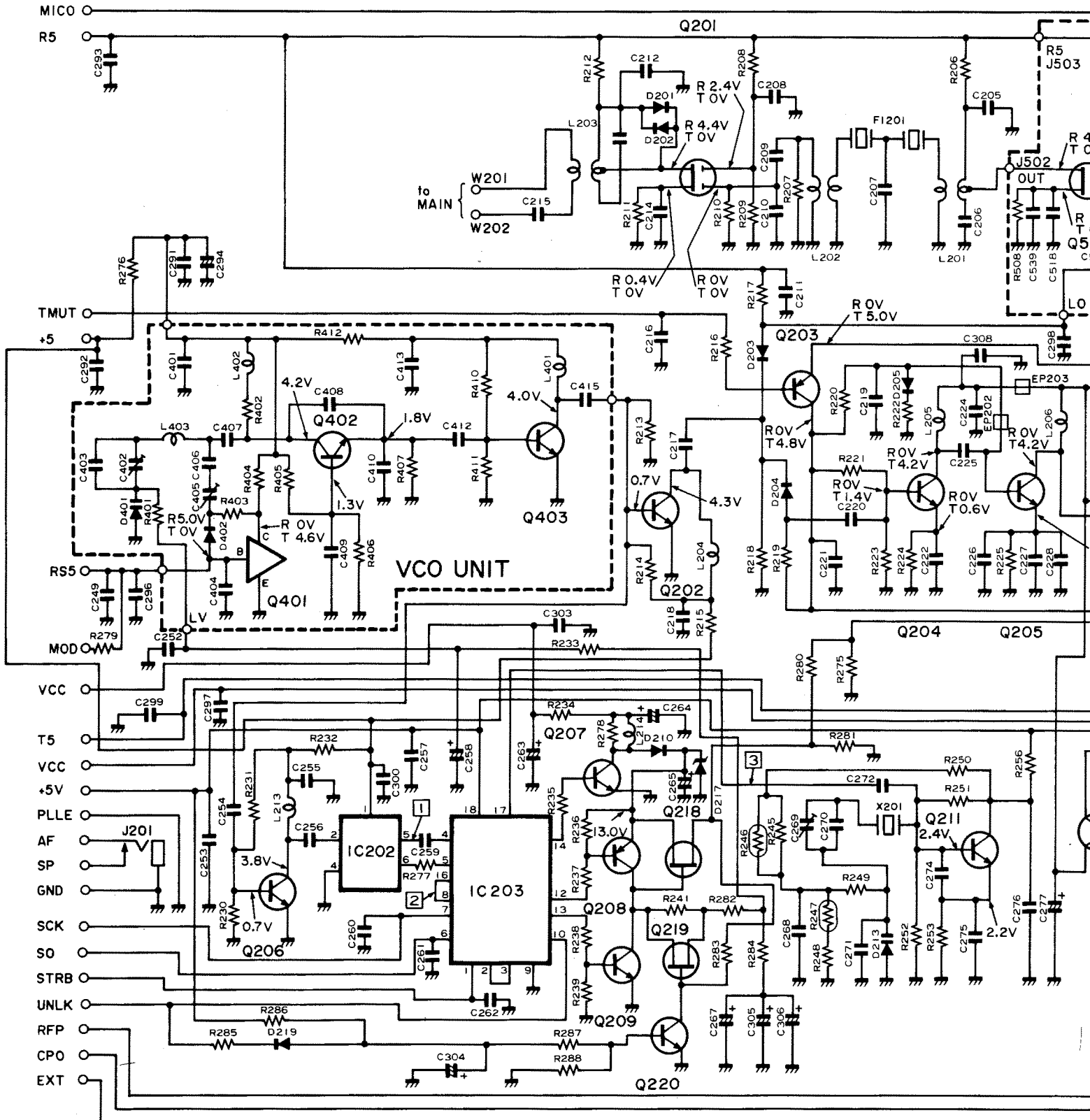

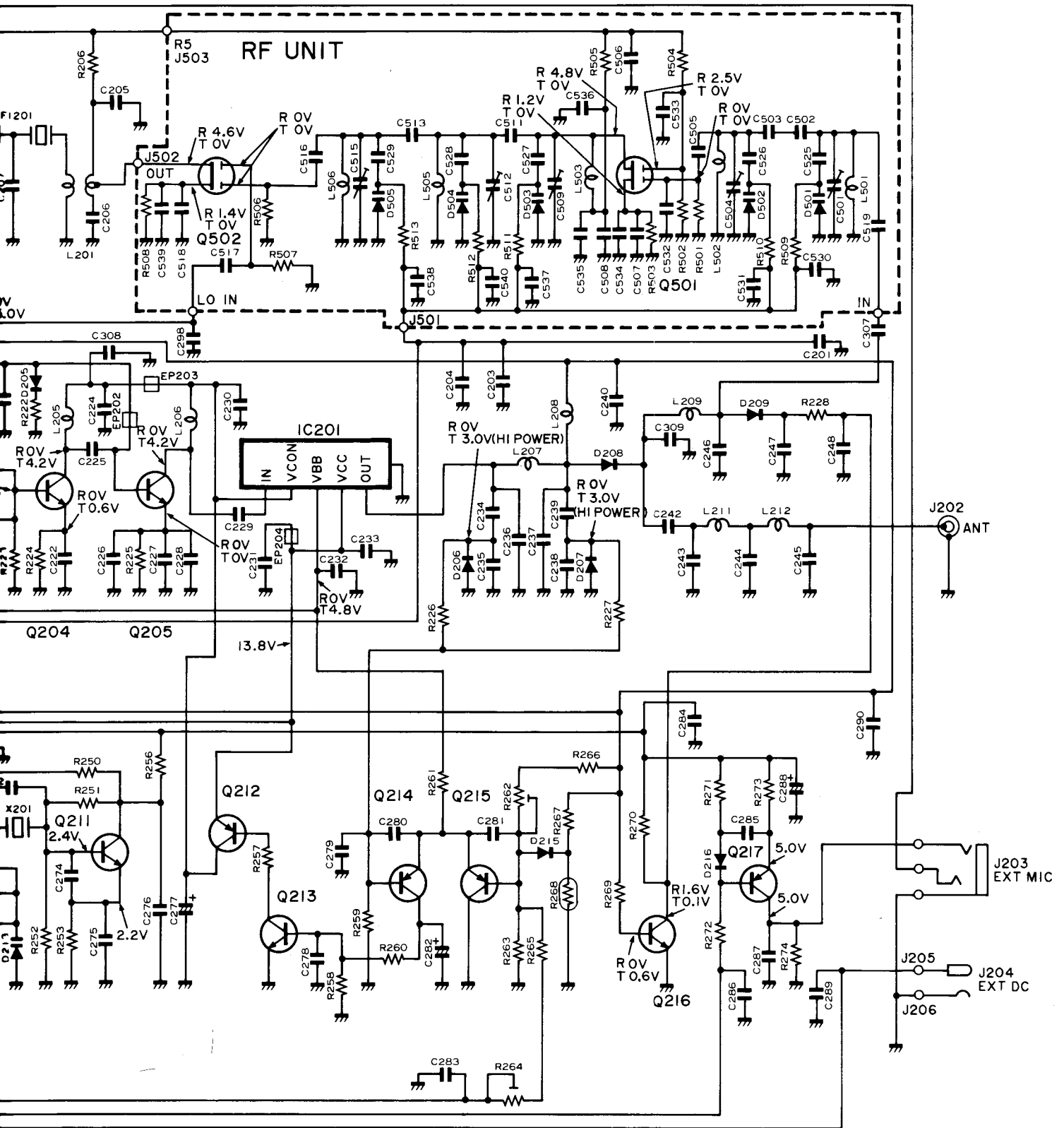

# LOGIC UNIT VOLTAGE DIAGRAM

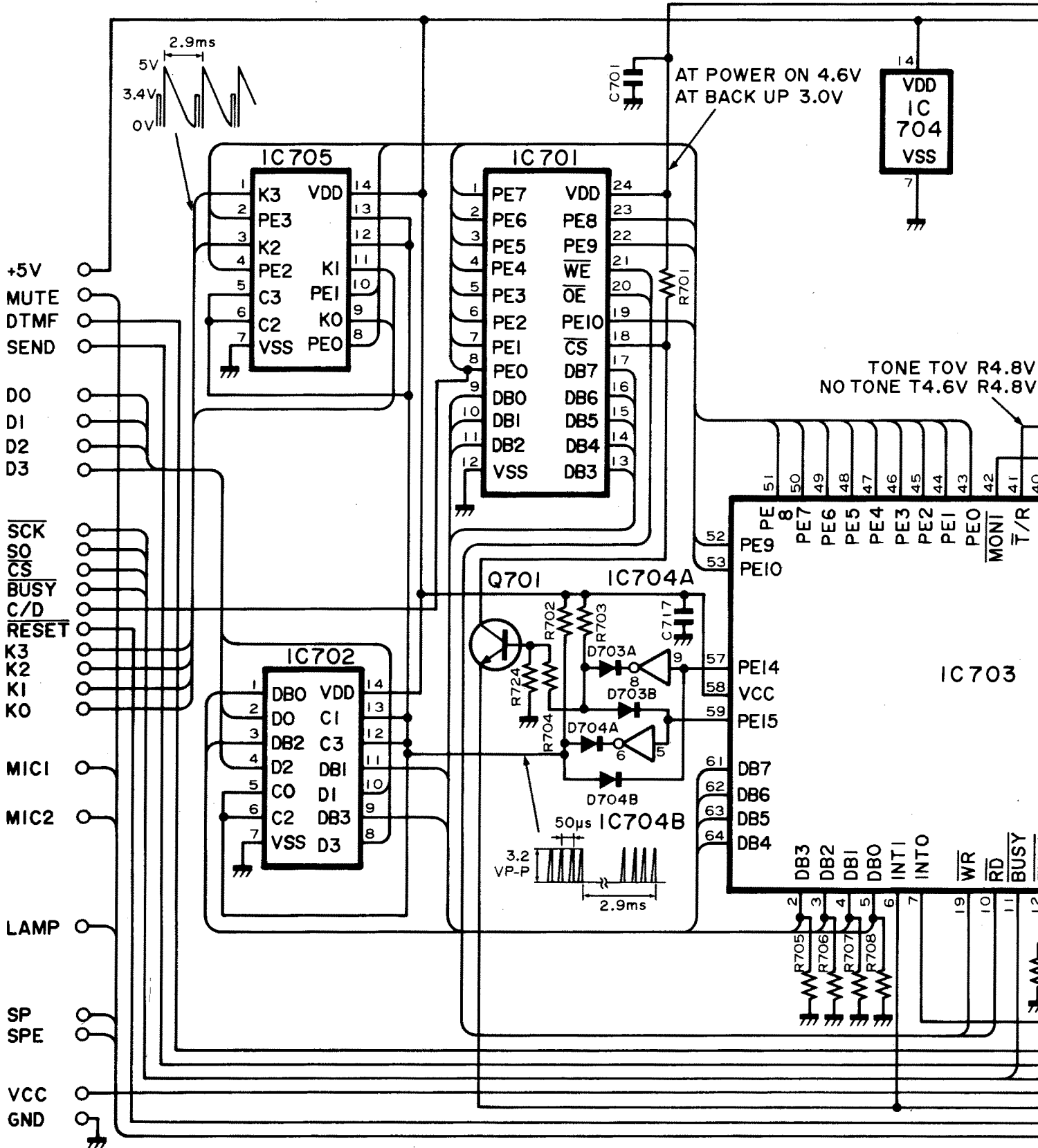

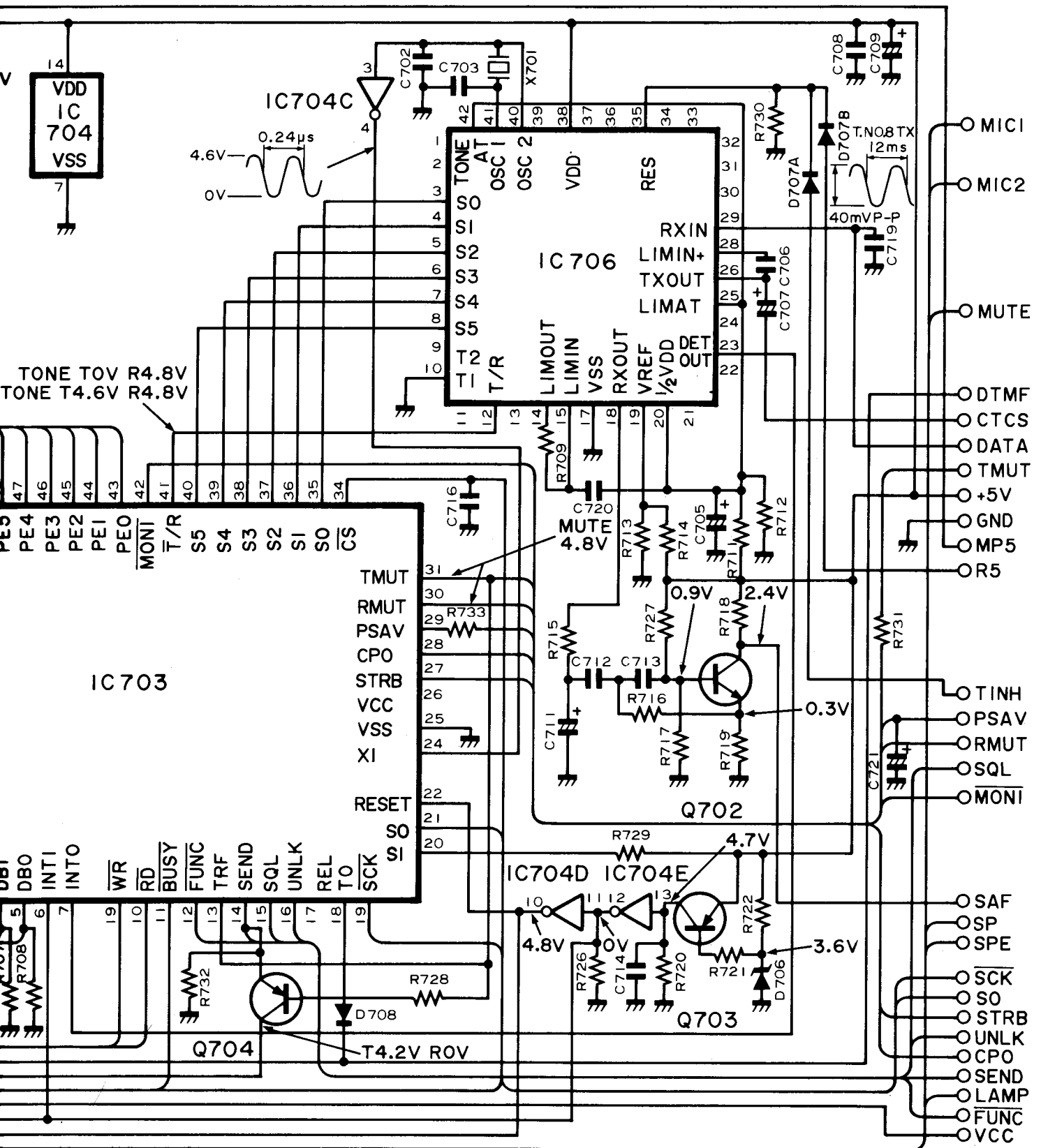

# DISPLAY UNIT VOLTAGE DIAGRAM

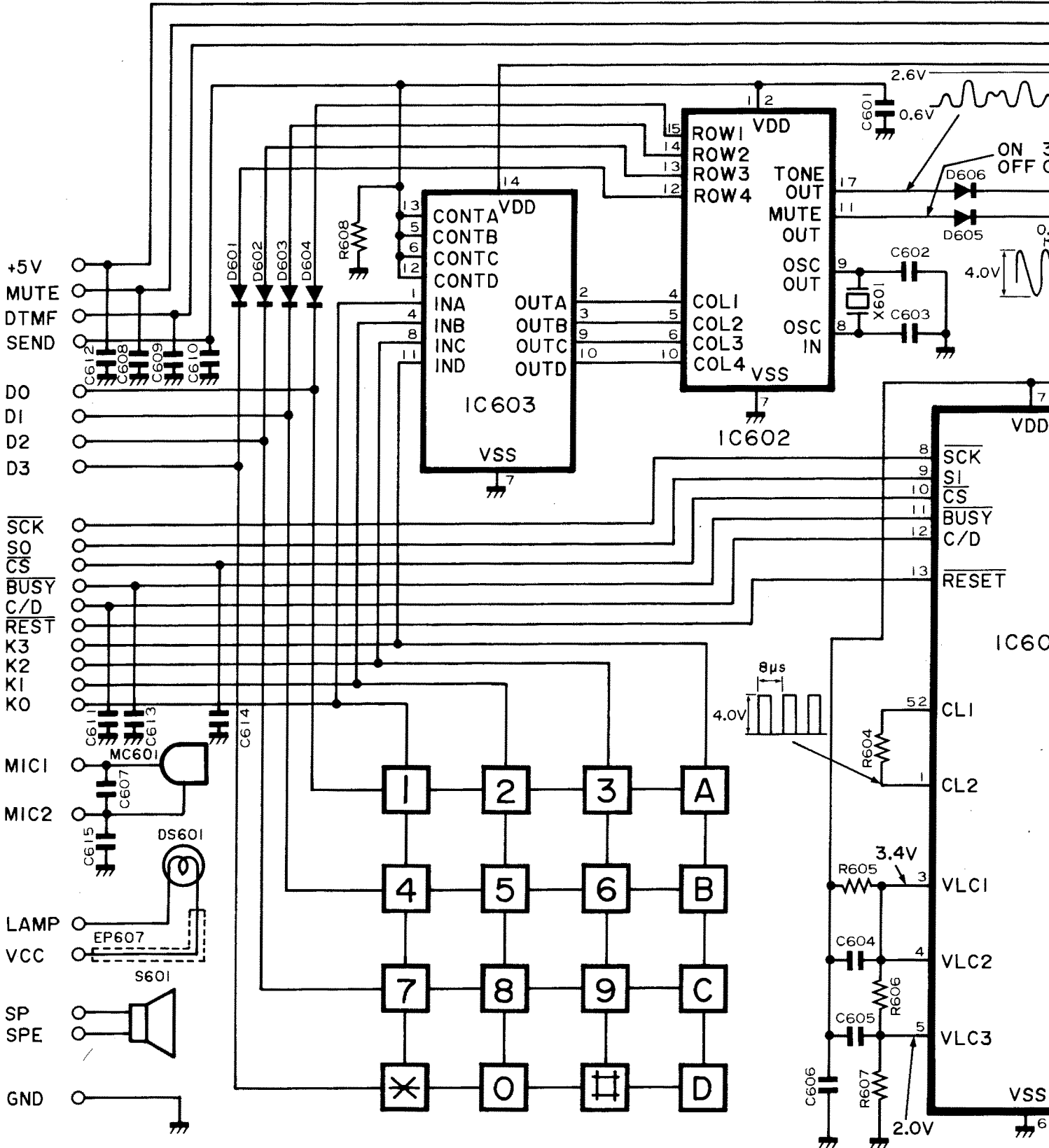

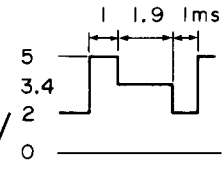
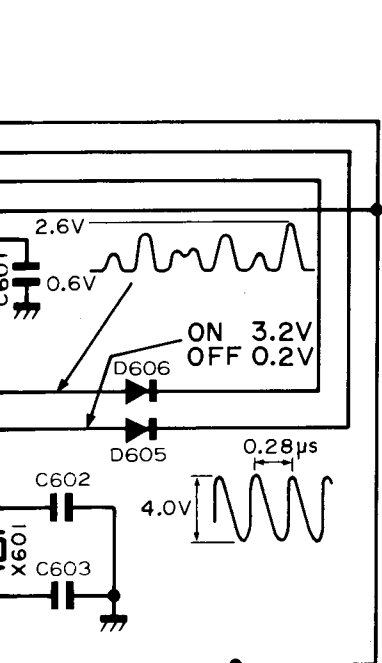

DS602

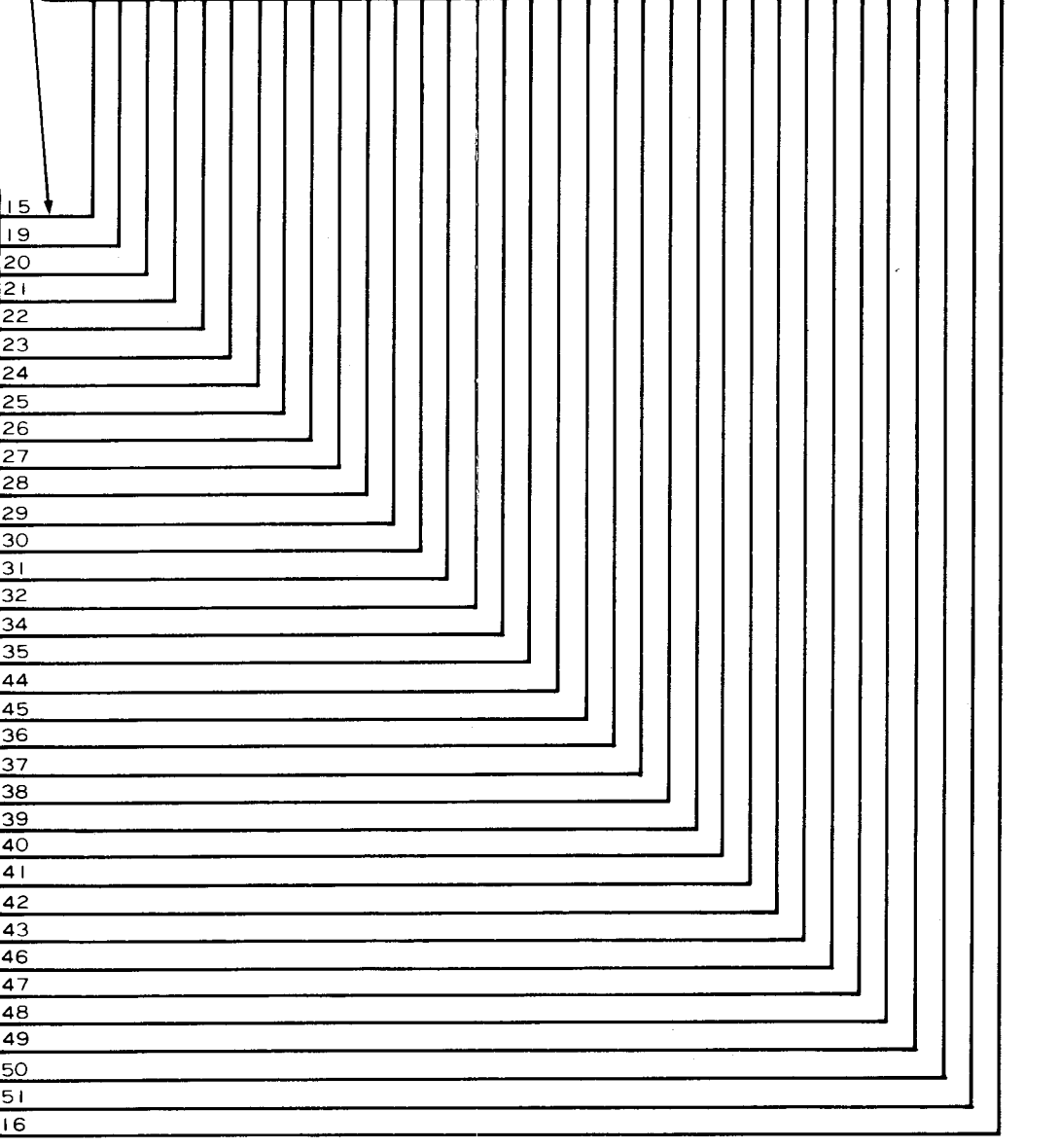
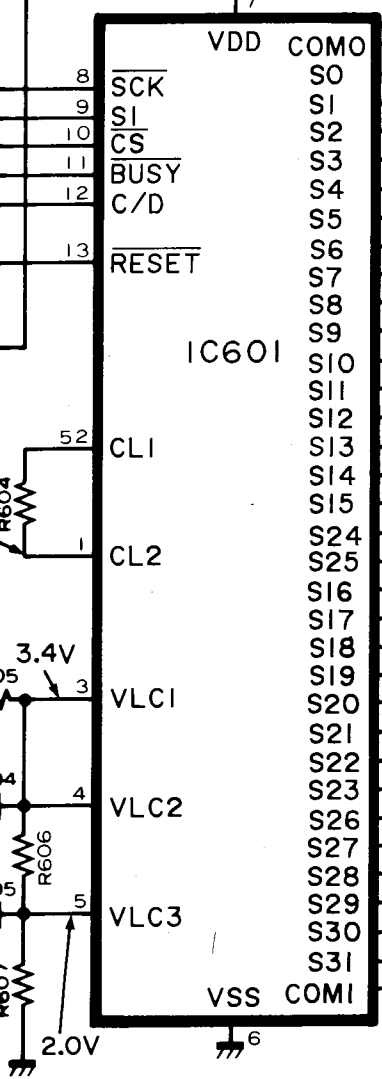
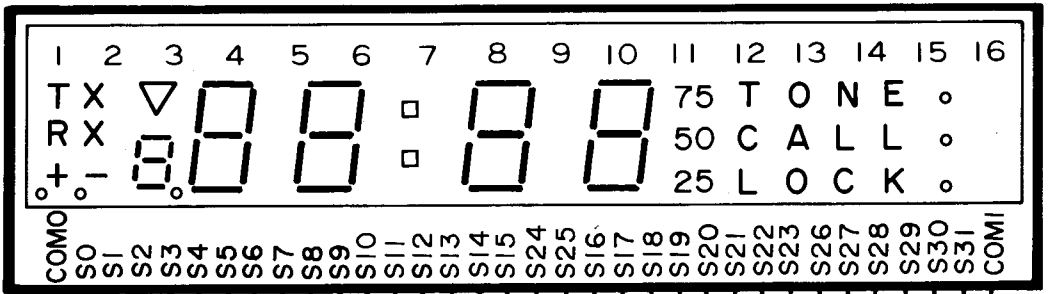

## SECTION 7 PARTS LIST

### [MAIN UNIT]

REF. NO.	ORDER NO.	DESCRIPTION	
IC101	1110000070	IC	μPC358C
IC102	1110000630	IC	MC3357P
IC103	1110000530	IC	LM386N-3
Q101	1530000110	Transistor	2SC2458-GR
Q102	1530000110	Transistor	2SC2458-GR
Q103	1510000080	Transistor	2SA1048-GR
Q104	1530000110	Transistor	2SC2458-GR
Q105	1530000110	Transistor	2SC2458-GR
Q106	1510000080	Transistor	2SA1048-GR
Q107	1510000080	Transistor	2SA1048-GR
Q108	1530000110	Transistor	2SC2458-GR
Q109	1510000080	Transistor	2SA1048-GR
Q110	1510000080	Transistor	2SA1048-GR
Q111	1530000110	Transistor	2SC2458-GR
Q112	1520000080	Transistor	2SB909M R
Q113	1530000110	Transistor	2SC2458-GR
Q114	1520000080	Transistor	2SB909M R
Q115	1530000110	Transistor	2SC2458-GR
Q116	1520000080	Transistor	2SB909M R
Q117	1530000110	Transistor	2SC2458-GR
Q118	1520000080	Transistor	2SB909M R
Q119	1530000960	Transistor	2SC3399
Q120	1590000280	FET	2SJ105-Y
Q121	1530000110	Transistor	2SC2458-GR
Q123	1540000150	Transistor	2SD1225M R
Q124	1530000110	Transistor	2SC2458-GR
Q125	1530000110	Transistor	2SC2458-GR
Q126	1530000110	Transistor	2SC2458-GR
Q127	1590000280	FET	2SJ105-Y
D101	1710000070	Diode	1SS233
D102	1710000170	Diode	1SS211
D103	1710000170	Diode	1SS211
D104	1710000170	Diode	1SS211
D105	1710000170	Diode	1SS211
D106	1710000170	Diode	1SS211
D107	1730000360	Zener	RD5.1JS B2
D108	1710000170	Diode	1SS211
D109	1710000170	Diode	1SS211
D110	1710000170	Diode	1SS211
D112	1710000170	Diode	1SS211
D113	1730000420	Zener	RD12JS B2
D114	1710000170	Diode	1SS211
D115	1710000170	Diode	1SS211
D116	1710000170	Diode	1SS211
D117	1710000170	Diode	1SS211
D118	1710000170	Diode	1SS211
D119	1710000170	Diode	1SS211
D120	1710000170	Diode	1SS211
D121	1710000170	Diode	1SS211
D122	1710000170	Diode	1SS211
D123	1730000140	Zener	RD6.8E B2
L101	6180000880	Coil	LAL 03NA 100K
RL101	6330000560	Relay	OUC-SH-114D
FI101	2020000120	Filter	CFW455E(#01)
	2020000150	Filter	CFW455HT(#02)
	2020000120	Filter	CFW455E(#03)
	2020000120	Filter	CFW455E(#04)
	2020000120	Filter	CFW455E(#05)
	2020000120	Filter	CFW455E(#06)
X101	6050002000	Crystal	CR-70
X102	6070000010	Discriminator	CDB455C7A
R101	7010002120	Resistor	ELR10J 33k Ω
R102	7010002680	Resistor	R10J 1k Ω

### [MAIN UNIT]

REF. NO.	ORDER NO.	DESCRIPTION	
R103	7010001940	Resistor	ELR10J 1k Ω
R104	7010001950	Resistor	ELR10J 1.2k Ω
R105	7010002200	Resistor	ELR10J 150k Ω
R106	7010002180	Resistor	ELR10J 100k Ω
R107	7010002190	Resistor	ELR10J 120k Ω
R108	7010002190	Resistor	ELR10J 120k Ω
R109	7010001900	Resistor	ELR10J 470 Ω
R110	7010002070	Resistor	ELR10J 12k Ω
R111	7010002030	Resistor	ELR10J 5.6k Ω
R112	7310000570	Trimmer	RH0521CN4J05A (333)
R113	7010002240	Resistor	ELR10J 330k Ω
R114	7010002070	Resistor	ELR10J 12k Ω
R115	7310000590	Trimmer	RH0521C15J05A (104)
R116	7010001870	Resistor	ELR10J 270 Ω
R117	7010001980	Resistor	ELR10J 2.2k Ω
R118	7010001940	Resistor	ELR10J 1k Ω
R119	7010002000	Resistor	ELR10J 3.3k Ω
R120	7010002200	Resistor	ELR10J 150k Ω
R121	7010002220	Resistor	ELR10J 220k Ω
R122	7010002130	Resistor	ELR10J 39k Ω
R123	7010002080	Resistor	ELR10J 10k Ω
R124	7010002120	Resistor	ELR10J 33k Ω
R125	7010002110	Resistor	ELR10J 27k Ω
R126	7010002130	Resistor	ELR10J 39k Ω
R127	7010002070	Resistor	ELR10J 12k Ω
R128	7010001960	Resistor	ELR10J 1.5k Ω (#01)
	7010002000	Resistor	ELR10J 3.3k Ω (#02)
	7010001980	Resistor	ELR10J 1.5k Ω (#03)
	7010001980	Resistor	ELR10J 1.5k Ω (#04)
	7010001960	Resistor	ELR10J 1.5k Ω (#05)
	7010001980	Resistor	ELR10J 1.5k Ω (#06)
R129	7010001900	Resistor	ELR10J 470 Ω
R130	7010002140	Resistor	ELR10J 47k Ω
R131	7010001960	Resistor	ELR10J 1.5k Ω (#01)
	7010001980	Resistor	ELR10J 2.2k Ω (#02)
	7010001960	Resistor	ELR10J 1.5k Ω (#03)
	7010001960	Resistor	ELR10J 1.5k Ω (#04)
	7010001960	Resistor	ELR10J 1.5k Ω (#05)
	7010001960	Resistor	ELR10J 1.5k Ω (#06)
R132	7010001960	Resistor	ELR10J 1.5k Ω (#01)
	7010001980	Resistor	ELR10J 2.2k Ω (#02)
	7010001960	Resistor	ELR10J 1.5k Ω (#03)
	7010001960	Resistor	ELR10J 1.5k Ω (#04)
	7010001960	Resistor	ELR10J 1.5k Ω (#05)
	7010001960	Resistor	ELR10J 1.5k Ω (#06)
R133	7010002100	Resistor	ELR10J 22k Ω
R134	7010002140	Resistor	ELR10J 47k Ω
R135	7010002080	Resistor	ELR10J 10k Ω
R136	7010002180	Resistor	ELR10J 100k Ω
R137	7010002220	Resistor	ELR10J 220k Ω
R138	7010002120	Resistor	ELR10J 33k Ω
R139	7010002080	Resistor	ELR10J 10k Ω
R140	7010002210	Resistor	ELR10J 180k Ω
R141	7010002080	Resistor	ELR10J 10k Ω
R142	7010002080	Resistor	ELR10J 10k Ω
R143	7010002080	Resistor	ELR10J 10k Ω
R144	7010002080	Resistor	ELR10J 10k Ω
R145	7010002000	Resistor	ELR10J 3.3k Ω
R146	7010002080	Resistor	ELR10J 10k Ω
R147	7010002910	Resistor	R10J 100k Ω
R148	7210000240	Variable	RK094111000NA (10KB)
R149	7010002030	Resistor	ELR10J 5.6k Ω
R150	7010002240	Resistor	ELR10J 330k Ω
R151	7010002210	Resistor	ELR10J 180k Ω
R152	7010002300	Resistor	ELR10J 1M Ω
R153	7010002180	Resistor	ELR10J 100k Ω
R154	7010001940	Resistor	ELR10J 1k Ω
R155	7010002200	Resistor	ELR10J 150k Ω
R156	7010002290	Resistor	ELR10J 820k Ω
R159	7010002260	Resistor	ELR10J 470k Ω

[MAIN UNIT]

REF. NO.	ORDER NO.	DESCRIPTION
R160	7010002300	Resistor ELR10J 1M Ω
R161	7210000250	Variable RK0941111003A (10KA)
R162	7010001970	Resistor ELR10J 1.8k Ω (#01)
	7010002030	Resistor ELR10J 5.6k Ω (#02)
	7010001970	Resistor ELR10J 1.8k Ω (#03)
	7010001970	Resistor ELR10J 1.8k Ω (#04)
	7010001970	Resistor ELR10J 1.8k Ω (#05)
	7010001970	Resistor ELR10J 1.8k Ω (#06)
R164	7010002910	Resistor R10J 100k Ω
R165	7010002850	Resistor R10J 33k Ω
R166	7010002860	Resistor R10J 39k Ω
R167	7010002930	Resistor R10J 150k Ω (#01)
	7010002930	Resistor R10J 150k Ω (#02)
	7010002930	Resistor R10J 150k Ω (#03)
	7010002830	Resistor R10J 22k Ω (#04)
	7010002830	Resistor R10J 22k Ω (#05)
	7010002830	Resistor R10J 22k Ω (#06)
R168	7010002990	Resistor R10J 470k Ω
R172	7010002200	Resistor ELR10J 150k Ω
R178	7010001860	Resistor ELR10J 220 Ω
R179	7010002680	Resistor R10J 1k Ω
R180	7010002220	Resistor ELR10J 220k Ω
R181	7010002110	Resistor ELR10J 27k Ω (#01)
	7010002160	Resistor ELR10J 68k Ω (#02)
	7010002110	Resistor ELR10J 27k Ω (#03)
	7010002110	Resistor ELR10J 27k Ω (#04)
	7010002110	Resistor ELR10J 27k Ω (#05)
	7010002110	Resistor ELR10J 27k Ω (#06)
R182	7010002220	Resistor ELR10J 220k Ω
R183	7010002870	Resistor R10J 47k Ω
R184	7010002180	Resistor ELR10J 100k Ω
R185	7010002120	Resistor ELR10J 33k Ω
R186	7310000590	Trimmer RH0521C15J05A (104)
R187	7010002180	Resistor ELR10J 100k Ω
R188	7010001900	Resistor ELR10J 470 Ω
R189	7010002040	Resistor ELR10J 6.8k Ω
R191	7010002200	Resistor ELR10J 150k Ω
R192	7010001990	Resistor ELR10J 2.7k Ω
C101	4010000500	Ceramic DD104 B 102K 50V
C102	4510001550	Electrolytic 16 RC3 10 μF
C103	4510001550	Electrolytic 16 RC3 10 μF
C104	4040000190	Barrier Layer UAT 05X 103K
C105	4010000480	Ceramic DD104 B 471K 50V
C106	4010000280	Ceramic DD104 SL 470J 50V
C107	4010000280	Ceramic DD104 SL 470J 50V
C108	4010000480	Ceramic DD104 B 471K 50V
C109	4010000280	Ceramic DD104 SL 470J 50V
C110	4010000480	Ceramic DD104 B 471K 50V
C111	4550000320	Tantalum DN 1V 0R1M
C112	4510001600	Electrolytic 50 RC3 0.22 μF
C113	4010000280	Ceramic DD104 SL 470J 50V
C114	4010000280	Ceramic DD104 SL 470J 50V
C115	4010000500	Ceramic DD104 B 102K 50V
C116	4010000280	Ceramic DD104 SL 470J 50V
C117	4310000050	Mylar F2D 50V 222K
C118	4310000020	Mylar F2D 50V 103K
C119	4010000280	Ceramic DD104 SL 470J 50V
C120	4010000340	Ceramic DD105 SL 121J 50V
C121	4010000280	Ceramic DD104 SL 470J 50V
C122	4310000130	Mylar F2D 50V 563K
C123	4010000500	Ceramic DD104 B 102K 50V
C124	4010000320	Ceramic DD104 SL 820J 50V
C125	4510001590	Electrolytic 50 RC3 0.1 μF
C126	4040000280	Barrier Layer UZE 08X 104M
C127	4010000300	Ceramic DD104 SL 680J 50V
C128	4010000340	Ceramic DD105 SL 121J 50V
C130	4510001520	Electrolytic 6.3 RC3 47 μF
C131	4510001630	Electrolytic 50 RC3 2.2 μF
C132	4010000500	Ceramic DD104 B 102K 50V
C133	4510001510	Electrolytic 6.3 RC3 22 μF
C134	4510001510	Electrolytic 6.3 RC3 22 μF
C135	4010000280	Ceramic DD104 SL 470J 50V
C136	4510001510	Electrolytic 6.3 RC3 22 μF
C137	4010000280	Ceramic DD104 SL 470J 50V
C138	4510001510	Electrolytic 6.3 RC3 22 μF
C139	4010000480	Ceramic DD104 B 471K 50V

[MAIN UNIT]

REF. NO.	ORDER NO.	DESCRIPTION
C140	4010000500	Ceramic DD104 B 102K 50V
C141	4510001510	Electrolytic 6.3 RC3 22 μF
C142	4510002020	Electrolytic 25 MS7 47 μF
C143	4010000500	Ceramic DD104 B 102K 50V(#01)
	4010000500	Ceramic DD104 B 102K 50V(#02)
	4010000500	Ceramic DD104 B 102K 50V(#03)
	4010000500	Ceramic DD104 B 102K 50V(#04)
	4010000500	Ceramic DD104 B 102K 50V(#05)
	4010000500	Ceramic DD104 B 102K 50V(#06)
C144	4010000500	Ceramic DD104 B 102K 50V
C145	4010000120	Ceramic DD104 SL 100D 50V
C146	4010000500	Ceramic DD104 B 102K 50V
C147	4510001600	Electrolytic 50 RC3 0.22 μF
C148	4510001600	Electrolytic 50 RC3 0.22 μF
C149	4510001620	Electrolytic 50 RC3 1 μF
C150	4510001470	Electrolytic 50 MS5 1 μF
C151	4040000220	Barrier Layer UAT 06X 183K
C152	4510001890	Electrolytic 50 MS5 0R1 μF
C153	4510001350	Electrolytic 16 MS5 10 μF
C154	4510001350	Electrolytic 16 MS5 10 μF
C155	4510001550	Electrolytic 16 RC3 10 μF
C156	4510001630	Electrolytic 50 RC3 2.2 μF
C157	4510000450	Electrolytic 10 MS 220 μF
C158	4510001580	Electrolytic 25 RC3 4.7 μF
C159	4010000480	Ceramic DD104 B 471K 50V
C160	4010000280	Ceramic DD104 SL 470J 50V
C161	4010000280	Ceramic DD104 SL 470J 50V
C162	4010000280	Ceramic DD104 SL 470J 50V
C163	4010000280	Ceramic DD104 SL 470J 50V
C164	4010000280	Ceramic DD104 SL 470J 50V
C167	4510001580	Electrolytic 25 RC3 4.7 μF
C168	4510001620	Electrolytic 50 RC3 1 μF
C170	4040000190	Barrier Layer UAT 05X 103K
C171	4510001350	Electrolytic 16 MS5 10 μF
C172	4010000280	Ceramic DD104 SL 470J 50V
C173	4510001610	Electrolytic 50 RC3 0.47 μF
C174	4310000050	Mylar F2D 50V 222K
C175	4510001590	Electrolytic 50 RC3 0.1 μF
C176	4010000280	Ceramic DD104 SL 470J 50V
C177	4510001630	Electrolytic 50 RC3 2.2 μF
C178	4510001550	Electrolytic 16 RC3 10 μF
C179	4510001550	Electrolytic 16 RC3 10 μF
C180	4550000380	Tantalum DN 1V R47M
C181	4010000280	Ceramic DD104 SL 470J 50V
C182	4010000280	Ceramic DD104 SL 470J 50V
S101	2260000070	Switch SKHHA013A
S103	2260000070	Switch SKHHA013A
S104	2260000070	Switch SKHHA013A
S105	2230000250	Switch SPPH22014A
S106	2230000250	Switch SPPH22014A
BT101	3020000040	Lithium Battery BR2325-1HC
EP101	0910025871	P.C.Board B 2617A (MAIN)
EP102	0910007250	P.C.Board B 908
EP103	0910012020	P.C.Board B 1045
EP104	6910000970	Terminal DL 2OP 2.6-3-1.2H



## [PLL UNIT]

REF. NO.	ORDER NO.	DESCRIPTION		
IC201	1150000090	IC	S-AU16H(ICOM) / SC1030(#01)	
	1150000090	IC	S-AU16H(ICOM) / SC1030(#02)	
	1150000090	IC	S-AU16H(ICOM) / SC1030(#03)	
	1150000710	IC	S-AU16L(ICOM) / SC1090(#04)	
	1150000770	IC	S-AU16S (ICOM) / SC1099(#05)	
	1150000710	IC	S-AU16L(ICOM) / SC1090(#08)	
IC202	1110000080	IC	μ PB571C	
IC203	1130000530	IC	μ PD2834C	
Q201	1580000230	FET	3SK122 K	
Q202	1530000520	Transistor	2SC2028	
Q203	1520000070	Transistor	2SB561C	
Q204	1530000520	Transistor	2SC2028	
Q205	1530000530	Transistor	2SC2407	
Q206	1530000520	Transistor	2SC2028	
Q207	1530001740	Transistor	2SC3327-B	
Q208	1510000080	Transistor	2SA1048-GR	
Q209	1530000110	Transistor	2SC2458-GR	
Q211	1530000110	Transistor	2SC2458-GR	
Q212	1520000080	Transistor	2SB909M R	
Q213	1530000110	Transistor	2SC2458-GR	
Q214	1510000080	Transistor	2SA1048-GR	
Q215	1510000080	Transistor	2SA1048-GR	
Q216	1530000110	Transistor	2SC2458-GR	
Q217	1510000080	Transistor	2SA1048-GR	
Q218	1560000280	FET	2SK184-GR	
Q219	1560000010	FET	2SK184-Y	
Q220	1530000110	Transistor	2SC2458-GR	
D201	1790000240	Diode	1SS99	
D202	1790000240	Diode	1SS99	
D203	1710000180	Diode	1SS218	
D204	1710000180	Diode	1SS216	
D205	1710000170	Diode	1SS211	
D206	1790000250	Diode	1SS97	
D207	1790000250	Diode	1SS97	
D208	1710000180	Diode	1SS218	
D209	1710000180	Diode	1SS218	
D210	1710000430	Diode	1SS130	
D213	1720000050	Varicap	1SV50E	
D215	1710000170	Diode	1SS211	
D216	1710000170	Diode	1SS211	
D217	1730000500	Zener	RD13E B2	
D219	1710000170	Diode	1SS211	
L201	8150002000	Coil	LS-284	
L202	8150002000	Coil	LS-284	
L203	8150001990	Coil	LS-283	
L204	8110001520	Coil	LA-232(#01)	
	8110001520	Coil	LA-232(#02)	
	8110001520	Coil	LA-232(#03)	
	8110001530	Coil	LA-233(#04)	
	8110001520	Coil	LA-232(#05)	
	8110001530	Coil	LA-233(#06)	
	L205	8110000950	Coil	LA-128
	L206	8110000950	Coil	LA-128
	L207	8110001520	Coil	LA-232
		8110001520	Coil	LA-232(#01)
8110001590		Coil	LA-242(#02)	
8110001520		Coil	LA-232(#03)	
8110001590		Coil	LA-242(#04)	
8110001590		Coil	LA-242(#06)	
L208		8160002350	Coil	LAL 02NA R56K
L209	8110001990	Coil	LA-223(#01)	
	8110001520	Coil	LA-232(#02)	
	8110001990	Coil	LA-223(#03)	
	8110001520	Coil	LA-232(#04)	
	8110001520	Coil	LA-232(#05)	
	8110001520	Coil	LA-232(#06)	
	L211	8110002110	Coil	LA-382(#01)
8110001120	Coil	LA-147(#02)		
8110002110	Coil	LA-382(#03)		
8110002110	Coil	LA-382(#04)		
8110001120	Coil	LA-147(#05)		
8110002110	Coil	LA-382(#06)		
L212	8110001520	Coil	LA-232	
L213	8110001530	Coil	LA-233	

## [PLL UNIT]

REF. NO.	ORDER NO.	DESCRIPTION		
L214	8170000290	Coil	LW-30	
F1201	2010000200	Filter	21M15B3 (FL-42)(#01)	
	2010001020	Filter	21M 7B2 (FL-125)(#02)	
	2010000200	Filter	21M15B3 (FL-42)(#03)	
	2010000200	Filter	21M15B3 (FL-42)(#04)	
	2010000200	Filter	21M15B3 (FL-42)(#05)	
	2010000200	Filter	21M15B3 (FL-42)(#08)	
X201	8050002150	Crystal	CR-85	
R205	7030000460	Resistor	MCR10EZHZ 4.7k Ω (472)(#04)	
	7030000460	Resistor	MCR10EZHZ 4.7k Ω (472)(#05)	
R206	7010001820	Resistor	ELR10J 100 Ω	
	7010002060	Resistor	ELR10J 10k Ω (#01)	
R207	7010002060	Resistor	ELR10J 10k Ω (#02)	
	7010002060	Resistor	ELR10J 10k Ω (#03)	
	7010002020	Resistor	ELR10J 4.7k Ω (#04)	
	7010002020	Resistor	ELR10J 4.7k Ω (#05)	
	7010002020	Resistor	ELR10J 4.7k Ω (#06)	
	R208	7010002180	Resistor	ELR10J 100k Ω
	R209	7010002180	Resistor	ELR10J 100k Ω
	R210	7010002260	Resistor	ELR10J 470k Ω
	R211	7010001820	Resistor	ELR10J 100 Ω
	R212	7010001820	Resistor	ELR10J 100 Ω
R213	7010002020	Resistor	ELR10J 4.7k Ω	
R214	7010002080	Resistor	ELR10J 15k Ω	
R215	7010001820	Resistor	ELR10J 100 Ω	
R216	7010002040	Resistor	ELR10J 6.8k Ω	
R217	7030000500	Resistor	MCR10EZHZ 10k Ω (103)	
R218	7010002100	Resistor	ELR10J 22k Ω	
R219	7010002060	Resistor	ELR10J 10k Ω	
R220	7010001940	Resistor	ELR10J 1k Ω	
R221	7010001950	Resistor	ELR10J 1.2k Ω	
R222	7010001860	Resistor	ELR10J 220 Ω	
R223	7010001910	Resistor	ELR10J 560 Ω	
R224	7010001780	Resistor	ELR10J 47 Ω	
R225	7010001700	Resistor	ELR10J 10 Ω	
R226	7010002020	Resistor	ELR10J 4.7k Ω	
R227	7010002020	Resistor	ELR10J 4.7k Ω	
R228	7010001880	Resistor	ELR10J 330 Ω	
R230	7010001970	Resistor	ELR10J 1.8k Ω	
R231	7010002040	Resistor	ELR10J 6.8k Ω	
R232	7010001900	Resistor	ELR10J 470 Ω	
R233	7010002040	Resistor	ELR10J 6.8k Ω	
R234	7010001900	Resistor	ELR10J 470 Ω (#01)	
	7010001900	Resistor	ELR10J 470 Ω (#02)	
	7010001900	Resistor	ELR10J 470 Ω (#03)	
	7010001910	Resistor	ELR10J 560 Ω (#04)	
	7010001910	Resistor	ELR10J 560 Ω (#05)	
	7010001910	Resistor	ELR10J 560 Ω (#06)	
	R235	7010002060	Resistor	ELR10J 10k Ω (#01)
	7010002060	Resistor	ELR10J 10k Ω (#02)	
	7010002060	Resistor	ELR10J 10k Ω (#03)	
	7010002790	Resistor	R10J 10k Ω (#04)	
7010002790	Resistor	R10J 10k Ω (#05)		
7010002790	Resistor	R10J 10k Ω (#06)		
R236	7010002180	Resistor	ELR10J 100k Ω	
R237	7010002140	Resistor	ELR10J 47k Ω (#01)	
	7010002080	Resistor	ELR10J 15k Ω (#02)	
	7010002140	Resistor	ELR10J 47k Ω (#03)	
	7010002140	Resistor	ELR10J 47k Ω (#04)	
	7010002140	Resistor	ELR10J 47k Ω (#05)	
	7010002140	Resistor	ELR10J 47k Ω (#06)	
	R238	7010002090	Resistor	ELR10J 18k Ω
	R239	7010002180	Resistor	ELR10J 100k Ω
	R241	7010001990	Resistor	ELR10J 2.7k Ω (#01)
		7010001960	Resistor	ELR10J 1.5k Ω (#02)
7010001990		Resistor	ELR10J 2.7k Ω (#03)	
7010001990		Resistor	ELR10J 2.7k Ω (#04)	
7010001990		Resistor	ELR10J 2.7k Ω (#05)	
7010001990		Resistor	ELR10J 2.7k Ω (#06)	
R245		7010002060	Resistor	ELR10J 10k Ω
R246	7510000020	Thermistor	33D28	
R247	7510000020	Thermistor	33D28	
R248	7010002080	Resistor	ELR10J 15k Ω (#01)	

[PLL UNIT]

REF. NO.	ORDER NO.	DESCRIPTION
R248	7010002080	Resistor ELR10J 15k Ω (#02)
	7010002080	Resistor ELR10J 15k Ω (#03)
	7010002070	Resistor ELR10J 12k Ω (#04)
	7010002070	Resistor ELR10J 12k Ω (#05)
	7010002070	Resistor ELR10J 12k Ω (#08)
R249	7010002080	Resistor ELR10J 10k Ω
R250	7010002040	Resistor ELR10J 8.8k Ω
R251	7010002180	Resistor ELR10J 100k Ω
R252	7010002180	Resistor ELR10J 100k Ω
R253	7010001980	Resistor ELR10J 2.2k Ω
R256	7010001820	Resistor ELR10J 100 Ω
R257	7010001970	Resistor ELR10J 1.8k Ω
R258	7010002260	Resistor ELR10J 470k Ω
R259	7010002100	Resistor ELR10J 22k Ω
R260	7010002200	Resistor ELR10J 150k Ω
R261	7010002170	Resistor ELR10J 82k Ω
R262	7310001760	Trimmer RH0421CJ4J09A (223)
R263	7030000540	Resistor MCR10EZHZ 22k Ω (223)
R264	7310001750	Trimmer RH0421CJ3J09A (222)(#01)
	7310001750	Trimmer RH0421CJ3J09A (222)(#02)
	7310001750	Trimmer RH0421CJ3J09A (222)(#03)
	7310001800	Trimmer RH0421CN3J01A (332)(#04)
	7310001800	Trimmer RH0421CN3J01A (332)(#05)
	7310001800	Trimmer RH0421CN3J01A (332)(#08)
R265	7010001980	Resistor ELR10J 2.2k Ω
R266	7030000490	Resistor MCR10EZHZ 8.2k Ω (822)
R267	7030000500	Resistor MCR10EZHZ 10k Ω (103)(#01)
	7030000500	Resistor MCR10EZHZ 10k Ω (103)(#02)
	7030000500	Resistor MCR10EZHZ 10k Ω (103)(#03)
	7030000500	Resistor MCR10EZHZ 10k Ω (103)(#04)
	7030000530	Resistor MCR10EZHZ 18k Ω (183)(#05)
	7030000500	Resistor MCR10EZHZ 10k Ω (103)(#08)
R268	7510000080	Thermistor 112-503-2AI
R269	7010002140	Resistor ELR10J 47k Ω
R270	7010002300	Resistor ELR10J 1M Ω
R271	7010002030	Resistor ELR10J 5.8k Ω
R272	7010002140	Resistor ELR10J 47k Ω
R273	7010001750	Resistor ELR10J 27 Ω
R274	7010002140	Resistor ELR10J 47k Ω
R275	7030000740	Resistor MCR10EZHZ 1M Ω (105)
R276	7010001780	Resistor ELR10J 47 Ω
R277	7010002080	Resistor ELR10J 10k Ω
R278	7010002080	Resistor ELR10J 10k Ω
R279	7010002100	Resistor ELR10J 22k Ω
R280	7030000500	Resistor MCR10EZHZ 10k Ω (103)
R281	7030000830	Resistor MCR10EZHZ 120k Ω (124)
R282	7010002800	Resistor R10J 220 Ω
R283	7010004980	Resistor ELR10J 2.2M Ω
R284	7010001840	Resistor ELR10J 150 Ω
R285	7010002020	Resistor ELR10J 4.7k Ω
R286	7010002220	Resistor ELR10J 220k Ω
R287	7010002230	Resistor ELR10J 270k Ω
R288	7010002180	Resistor ELR10J 100k Ω
R289	7030000250	Resistor MCR10EZHZ 82 Ω (820)(#01)
	7030000250	Resistor MCR10EZHZ 82 Ω (820)(#03)
	7030000300	Resistor MCR10EZHZ 220 Ω (221)(#05)
R290	7010002180	Resistor ELR10J 100k Ω (#04)
	7010002180	Resistor ELR10J 100k Ω (#05)
	7010002180	Resistor ELR10J 100k Ω (#08)
R291	7010002080	Resistor ELR10J 10k Ω (#04)
	7010002080	Resistor ELR10J 10k Ω (#05)
	7010002080	Resistor ELR10J 10k Ω (#08)
R292	7010002000	Resistor ELR10J 3.3k Ω (#04)
	7010002000	Resistor ELR10J 3.3k Ω (#05)
	7010002000	Resistor ELR10J 3.3k Ω (#08)
R294	7030000180	Resistor MCR10EZHZ 22 Ω (220)(#02)
C201	4030001150	Ceramic GRM40 F 104Z 25PT
C203	4030000700	Ceramic GRM40 SL 470J 50PT
C204	4030000700	Ceramic GRM40 SL 470J 50PT
C205	4010000500	Ceramic DD104 B 102K 50V(#01)
	4010000500	Ceramic DD104 B 102K 50V(#02)
	4010000500	Ceramic DD104 B 102K 50V(#03)
	4040000190	Barrier Layer UAT 05X 103K(#04)
	4040000190	Barrier Layer UAT 05X 103K(#05)
	4040000190	Barrier Layer UAT 05X 103K(#08)
C206	4010000260	Ceramic DD104 SL 470J 50V(#01)

[PLL UNIT]

REF. NO.	ORDER NO.	DESCRIPTION
C206	4010000260	Ceramic DD104 SL 470J 50V(#02)
	4010000260	Ceramic DD104 SL 470J 50V(#03)
	4010000240	Ceramic DD104 SL 390J 50V(#04)
	4010000240	Ceramic DD104 SL 390J 50V(#05)
	4010000240	Ceramic DD104 SL 390J 50V(#08)
C207	4010000090	Ceramic DD104 SL 070D 50V(#01)
	4010000150	Ceramic DD104 SL 150J 50V(#02)
	4010000090	Ceramic DD104 SL 070D 50V(#03)
	4010000090	Ceramic DD104 SL 070D 50V(#04)
	4010000090	Ceramic DD104 SL 070D 50V(#05)
	4010000090	Ceramic DD104 SL 070D 50V(#08)
C208	4010000500	Ceramic DD104 B 102K 50V
C209	4010000380	Ceramic DD106 SL 181J 50V(#01)
	4010000380	Ceramic DD106 SL 181J 50V(#02)
	4010000380	Ceramic DD106 SL 181J 50V(#03)
	4010000350	Ceramic DD106 SL 151J 50V(#04)
	4010000350	Ceramic DD106 SL 151J 50V(#05)
	4010000350	Ceramic DD106 SL 151J 50V(#08)
C210	4010000290	Ceramic DD104 SL 620J 50V(#01)
	4010000290	Ceramic DD104 SL 620J 50V(#02)
	4010000290	Ceramic DD104 SL 620J 50V(#03)
	4010000280	Ceramic DD104 SL 560J 50V(#04)
	4010000280	Ceramic DD104 SL 560J 50V(#05)
	4010000280	Ceramic DD104 SL 560J 50V(#08)
C211	4030001100	Ceramic GRM40 B 102K 50PT
C212	4010000500	Ceramic DD104 B 102K 50V
C214	4010000500	Ceramic DD104 B 102K 50V
C215	4010000500	Ceramic DD104 B 102K 50V
C216	4010000480	Ceramic DD104 B 471K 50V
C217	4010000100	Ceramic DD104 SL 080D 50V(#01)
	4010000100	Ceramic DD104 SL 080D 50V(#02)
	4010000100	Ceramic DD104 SL 080D 50V(#03)
	4010000100	Ceramic DD104 SL 080D 50V(#04)
	4010000080	Ceramic DD104 SL 080D 50V(#05)
	4010000100	Ceramic DD104 SL 080D 50V(#08)
C218	4010000500	Ceramic DD104 B 102K 50V
C219	4010000500	Ceramic DD104 B 102K 50V
C220	4010000080	Ceramic DD104 SL 080D 50V
C221	4010000480	Ceramic DD104 B 471K 50V
C222	4010000280	Ceramic DD104 SL 470J 50V
C224	4010000500	Ceramic DD104 B 102K 50V
C225	4010000080	Ceramic DD104 SL 040C 50V
C226	4010000500	Ceramic DD104 B 102K 50V(#01)
	4010000500	Ceramic DD104 B 102K 50V(#02)
	4010000500	Ceramic DD104 B 102K 50V(#03)
	4010000500	Ceramic DD104 B 102K 50V(#04)
	4010000500	Ceramic DD104 B 102K 50V(#05)
	4010000500	Ceramic DD104 B 102K 50V(#08)
C227	4010000500	Ceramic DD104 B 102K 50V(#01)
	4010000500	Ceramic DD104 B 102K 50V(#02)
	4010000500	Ceramic DD104 B 102K 50V(#03)
	4010000500	Ceramic DD104 B 102K 50V(#04)
C228	4010000480	Ceramic DD104 B 471K 50V(#01)
	4010000480	Ceramic DD104 B 471K 50V(#02)
	4010000480	Ceramic DD104 B 471K 50V(#03)
	4010000480	Ceramic DD104 B 471K 50V(#04)
	4010000480	Ceramic DD104 B 471K 50V(#05)
	4010000480	Ceramic DD104 B 471K 50V(#08)
C229	4010000140	Ceramic DD104 SL 120J 50V(#01)
	4010000140	Ceramic DD104 SL 120J 50V(#02)
	4010000140	Ceramic DD104 SL 120J 50V(#03)
	4010000140	Ceramic DD104 SL 120J 50V(#04)
	4010000140	Ceramic DD104 SL 120J 50V(#05)
	4010000140	Ceramic DD104 SL 120J 50V(#08)
C230	4010000500	Ceramic DD104 B 102K 50V
C231	4010000260	Ceramic DD104 SL 470J 50V
C232	4010000260	Ceramic DD104 SL 470J 50V
C233	4010000500	Ceramic DD104 B 102K 50V
C234	4010000020	Ceramic DD104 SL 010C 50V
C235	4010000070	Ceramic DD104 SL 050C 50V
C236	4010000070	Ceramic DD104 SL 050C 50V
C237	4010000110	Ceramic DD104 SL 090D 50V
C238	4010000070	Ceramic DD104 SL 050C 50V
C239	4010000020	Ceramic DD104 SL 010C 50V
C240	4010000500	Ceramic DD104 B 102K 50V
C242	4010000160	Ceramic DD104 SL 180J 50V(#01)
	4010000160	Ceramic DD104 SL 180J 50V(#02)
	4010000160	Ceramic DD104 SL 180J 50V(#03)

[PLL UNIT]

REF. NO.	ORDER NO.	DESCRIPTION
C242	4010000180	Ceramic DD104 SL 220J 50V(#04)
	4010000180	Ceramic DD104 SL 180J 50V(#05)
	4010000180	Ceramic DD104 SL 220J 50V(#08)
C243	4010000100	Ceramic DD104 SL 080D 50V(#01)
	4010000100	Ceramic DD104 SL 080D 50V(#02)
	4010000100	Ceramic DD104 SL 080D 50V(#03)
	4010000140	Ceramic DD104 SL 120J 50V(#04)
	4010000100	Ceramic DD104 SL 080D 50V(#05)
	4010000140	Ceramic DD104 SL 120J 50V(#08)
C244	4010000120	Ceramic DD104 SL 100D 50V(#01)
	4010000120	Ceramic DD104 SL 100D 50V(#02)
	4010000120	Ceramic DD104 SL 100D 50V(#03)
	4010000150	Ceramic DD104 SL 150J 50V(#04)
	4010000120	Ceramic DD104 SL 100D 50V(#05)
	4010000150	Ceramic DD104 SL 150J 50V(#06)
C245	4010000080	Ceramic DD104 SL 080D 50V(#01)
	4010000080	Ceramic DD104 SL 080D 50V(#02)
	4010000080	Ceramic DD104 SL 080D 50V(#03)
	4010000120	Ceramic DD104 SL 100D 50V(#04)
	4010000080	Ceramic DD104 SL 080D 50V(#05)
	4010000120	Ceramic DD104 SL 100D 50V(#08)
C246	4010000080	Ceramic DD104 SL 080D 50V
C247	4010000190	Ceramic DD104 SL 240J 50V(#01)
	4010000190	Ceramic DD104 SL 240J 50V(#02)
	4010000190	Ceramic DD104 SL 240J 50V(#03)
	4010000190	Ceramic DD104 SL 240J 50V(#04)
	4010000180	Ceramic DD104 SL 220J 50V(#05)
	4010000190	Ceramic DD104 SL 240J 50V(#08)
C248	4010000280	Ceramic DD104 SL 470J 50V
C249	4010000280	Ceramic DD104 SL 470J 50V
C252	4010000280	Ceramic DD104 SL 470J 50V(#01)
	4010000280	Ceramic DD104 SL 470J 50V(#02)
	4010000280	Ceramic DD104 SL 470J 50V(#03)
C253	4010000460	Ceramic DD104 B 471K 50V
C254	4010000060	Ceramic DD104 SL 040C 50V(#01)
	4010000060	Ceramic DD104 SL 040C 50V(#02)
	4010000060	Ceramic DD104 SL 040C 50V(#03)
	4010000060	Ceramic DD104 SL 040C 50V(#04)
	4010000060	Ceramic DD104 SL 040C 50V(#05)
	4010000060	Ceramic DD104 SL 040C 50V(#08)
C255	4010000500	Ceramic DD104 B 102K 50V
C256	4010000120	Ceramic DD104 SL 100D 50V
C257	4010004540	Ceramic RPE121R104M50
C258	4550000320	Tantalum DN 1V 0R1M
C259	4010000500	Ceramic DD104 B 102K 50V
C260	4010000260	Ceramic DD104 SL 470J 50V
C261	4010000260	Ceramic DD104 SL 470J 50V
C262	4010000260	Ceramic DD104 SL 470J 50V
C263	4510002280	Electrolytic 18 RC3 22µ F
C264	4510002280	Electrolytic 18 RC3 22µ F
C265	4510002280	Electrolytic 18 RC3 22µ F
C266	4550000320	Tantalum DN 1V 0R1M(#04)
	4550000310	Tantalum DN 1V 2R2M(#05)
	4550000320	Tantalum DN 1V 0R1M(#08)
C267	4550000340	Tantalum DN 1C 100M
C268	4010000500	Ceramic DD104 B 102K 50V
C269	4810000280	Trimmer ECRGA010D30
C270	4010000820	Ceramic DD105 CH 330J 50V
C271	4010000840	Ceramic DD104 CH 040C 50V
C272	4010000500	Ceramic DD104 B 102K 50V
C274	4010000380	Ceramic DD107 SL 221J 50V
C275	4010000330	Ceramic DD105 SL 101J 50V
C276	4040000190	Barrier Layer UAT 05X 103K
C277	4550002120	Tantalum DN 1C 220M(#01)
	4550002120	Tantalum DN 1C 220M(#02)
	4550002120	Tantalum DN 1C 220M(#03)
	4550002120	Tantalum DN 1C 220M(#04)
	4550002120	Tantalum DN 1C 220M(#05)
	4550002120	Tantalum DN 1C 220M(#08)
C278	4010000260	Ceramic DD104 SL 470J 50V(#04)
	4010000260	Ceramic DD104 SL 470J 50V(#05)
	4010000260	Ceramic DD104 SL 470J 50V(#08)
C279	4010000260	Ceramic DD104 SL 470J 50V
C280	4010000260	Ceramic DD104 SL 470J 50V
C281	4010000260	Ceramic DD104 SL 470J 50V
C283	4010000260	Ceramic DD104 SL 470J 50V
C284	4010000460	Ceramic DD104 B 471K 50V

[PLL UNIT]

REF. NO.	ORDER NO.	DESCRIPTION
C285	4010000260	Ceramic DD104 SL 470J 50V
C286	4010000260	Ceramic DD104 SL 470J 50V(#01)
	4010000260	Ceramic DD104 SL 470J 50V(#02)
	4010000260	Ceramic DD104 SL 470J 50V(#03)
C287	4010000260	Ceramic DD104 SL 470J 50V(#01)
	4010000260	Ceramic DD104 SL 470J 50V(#02)
	4010000260	Ceramic DD104 SL 470J 50V(#03)
	4010000460	Ceramic DD104 B 471K 50V(#04)
	4010000260	Ceramic DD104 SL 470J 50V(#05)
	4010000460	Ceramic DD104 B 471K 50V(#08)
C288	4510001200	Electrolytic 6.3 RC2 22µ F
C289	4010000460	Ceramic DD104 B 471K 50V
C290	4010000460	Ceramic DD104 B 471K 50V
C291	4040000260	Barrier Layer UZE 08X 104M
C292	4010000460	Ceramic DD104 B 471K 50V
C293	4030001100	Ceramic GRM40 B 102K 50PT
C294	4510002300	Electrolytic 6.3 RC2 100µ F
C296	4010000260	Ceramic DD104 SL 470J 50V
C297	4010000260	Ceramic DD104 SL 470J 50V
C298	4030000820	Ceramic GRM40 SL 080D 50PT
C299	4010000260	Ceramic DD104 SL 470J 50V
C300	4010004540	Ceramic RPE121R104M50
C303	4010000260	Ceramic DD104 SL 470J 50V
C304	4550000350	Tantalum DN 1V 010M
C305	4550000340	Tantalum DN 1C 100M
C306	4550000340	Tantalum DN 1C 100M(#01)
	4550000340	Tantalum DN 1C 100M(#02)
	4550000340	Tantalum DN 1C 100M(#03)
C307	4030000560	Ceramic GRM40 SL 020C 50PT
C308	4010000500	Ceramic DD104 B 102K 50V
C309	4010000040	Ceramic DD104 SL 020C 50V
C310	4010000500	Ceramic DD104 B 102K 50V(#01)
	4010000500	Ceramic DD104 B 102K 50V(#02)
	4010000500	Ceramic DD104 B 102K 50V(#03)
	4010000500	Ceramic DD104 B 102K 50V(#04)
	4010000500	Ceramic DD104 B 102K 50V(#05)
	4010000500	Ceramic DD104 B 102K 50V(#08)
C311	4010000020	Ceramic DD104 SL 010C 50V(#04)
	4010000020	Ceramic DD104 SL 010C 50V(#08)
C312	4010000260	Ceramic DD104 SL 470J 50V(#04)
	4010000260	Ceramic DD104 SL 470J 50V(#05)
	4010000260	Ceramic DD104 SL 470J 50V(#08)
C315	4030000700	Ceramic GRM40 SL 470J 50PT(#04)
	4030000700	Ceramic GRM40 SL 470J 50PT(#05)
	4030000700	Ceramic GRM40 SL 470J 50PT(#08)
C316	4010000460	Ceramic DD104 B 471K 50V(#04)
	4010000460	Ceramic DD104 B 471K 50V(#05)
	4010000460	Ceramic DD104 B 471K 50V(#08)
C317	4580000020	Capacitor D33Y5V 1E 104Z21(#04)
	4580000020	Capacitor D33Y5V 1E 104Z21(#05)
	4580000020	Capacitor D33Y5V 1E 104Z21(#08)
C318	4030001100	Ceramic GRM40 B 102K 50PT(#04)
	4030001100	Ceramic GRM40 B 102K 50PT(#05)
	4030001100	Ceramic GRM40 B 102K 50PT(#08)
C319	4010000460	Ceramic DD104 B 471K 50V
C320	4010000460	Ceramic DD104 B 471K 50V
C321	4010000460	Ceramic DD104 B 471K 50V
W205	7120000010	Jumper JPW 02A
W209	7120000010	Jumper JPW 02A(#01)
	7120000010	Jumper JPW 02A(#03)
	7120000010	Jumper JPW 02A(#04)
	7120000010	Jumper JPW 02A(#05)
	7120000010	Jumper JPW 02A(#06)
W210	7120000010	Jumper JPW 02A(#01)
	7120000010	Jumper JPW 02A(#03)
	7120000010	Jumper JPW 02A(#04)
	7120000010	Jumper JPW 02A(#05)
	7120000010	Jumper JPW 02A(#08)
J201	8450000110	Connector HSJ0836-01-010
J202	8510004920	Connector TNC-102-N1-W1-L1
J203	8450000130	Connector HSJ1102-01-540
J204	8450000220	Connector HEC0747-01-010
J205	8510004540	Connector 171255-1
J206	8510004540	Connector 171255-1

[PLL UNIT]

REF. NO.	ORDER NO.	DESCRIPTION
EP201	0910025861	P.C.Board B 2618A #01 (PLL)
	0910025861	P.C.Board B 2618A (#02)
	0910025861	P.C.Board B 2618A (#03)
	0910018781	P.C.Board B 1794A (#04) (PLL)
	0910018781	P.C.Board B 1794A (#05)
	0910018781	P.C.Board B 1794A (#06)
EP202	6910000970	Terminal DL 20P 2.6-3-1.2H
EP203	6910000970	Terminal DL 20P 2.6-3-1.2H
EP204	6910000970	Terminal DL 20P 2.6-3-1.2H
EP215	0910012080	P.C.Board B 1044
EP218	6910000970	Terminal DL 20P 2.6-3-1.2H(#04)
	6910000970	Terminal DL 20P 2.6-3-1.2H(#05)
	6910000970	Terminal DL 20P 2.6-3-1.2H(#06)
EP225	0910022321	P.C.Board B 2176A (#02)
	0910022321	P.C.Board B 2176A (#06)

[VCO UNIT]

REF. NO.	ORDER NO.	DESCRIPTION	
C409	4030001090	Ceramic GRM40 B 471K 50PT	
C410	4030000600	Ceramic GRM40 SL 060D 50PT(#01)	
	4030000600	Ceramic GRM40 SL 060D 50PT(#02)	
	4030000600	Ceramic GRM40 SL 060D 50PT(#03)	
	4030000600	Ceramic GRM40 SL 060D 50PT(#04)	
	4030000580	Ceramic GRM40 SL 040C 50PT(#05)	
	4030000600	Ceramic GRM40 SL 060D 50PT(#06)	
	C412	4030000550	Ceramic GRM40 SL 010C 50PT(#01)
		4030000540	Ceramic GRM40 SL 0R5C 50PT(#02)
		4030000550	Ceramic GRM40 SL 010C 50PT(#03)
		4030003170	Ceramic GRM40 SL 0R75C 50PT(#04)
		4030003170	Ceramic GRM40 SL 0R75C 50PT(#05)
		4030003170	Ceramic GRM40 SL 0R75C 50PT(#06)
C413	4030001090	Ceramic GRM40 B 471K 50PT	
C415	4010000080	Ceramic DD104 SL 060D 50V	
EP401	0910007472	P.C.Board B 930 (VCO)	

[VCO UNIT]

REF. NO.	ORDER NO.	DESCRIPTION	
Q401	1590000040	Transistor DTC124EK T148	
Q402	1530000370	Transistor 2SC3356-T2B	
Q403	1530000370	Transistor 2SC3356-T2B	
D401	1720000180	Varicap 1SV164-T2B	
D402	1710000180	Diode 1SS216	
L401	8110001360	Coil LA-182	
	8200000010	Coil LQN 5N 1R0M	
	8110001040	Coil LA-135(#01)	
	8110001040	Coil LA-135(#02)	
	8110001040	Coil LA-135(#03)	
	8110001040	Coil LA-135(#04)	
	8110002140	Coil LA-384(#05)	
	8110001040	Coil LA-135(#06)	
R401	7010002680	Resistor R10J 1k Q	
R402	7030000280	Resistor MCR10EZHZ 150 Q (151)(#01)	
	7030000280	Resistor MCR10EZHZ 100 Q (101)(#02)	
	7030000280	Resistor MCR10EZHZ 150 Q (151)(#03)	
	7030000280	Resistor MCR10EZHZ 150 Q (151)(#04)	
	7030000280	Resistor MCR10EZHZ 150 Q (151)(#05)	
	7030000280	Resistor MCR10EZHZ 150 Q (151)(#06)	
	7030000460	Resistor MCR10EZHZ 4.7k Q (472)	
	7030000580	Resistor MCR10EZHZ 47k Q (473)	
	7030000480	Resistor MCR10EZHZ 6.8k Q (682)	
	7030000460	Resistor MCR10EZHZ 4.7k Q (472)	
R403	7030000460	Resistor MCR10EZHZ 4.7k Q (472)	
R404	7030000300	Resistor MCR10EZHZ 220 Q (221)	
R410	7030000480	Resistor MCR10EZHZ 6.8k Q (682)	
R411	7030000410	Resistor MCR10EZHZ 1.6k Q (182)	
R412	7030000300	Resistor MCR10EZHZ 220 Q (221)(#01)	
	7030000280	Resistor MCR10EZHZ 100 Q (101)(#02)	
	7030000300	Resistor MCR10EZHZ 220 Q (221)(#03)	
	7030000300	Resistor MCR10EZHZ 220 Q (221)(#04)	
	7030000300	Resistor MCR10EZHZ 220 Q (221)(#05)	
	7030000300	Resistor MCR10EZHZ 220 Q (221)(#06)	
	C401	4010000460	Ceramic DD104 B 471K 50V
	C402	4610000520	Trimmer TZB04N100BA006
	C403	4030000640	Ceramic GRM40 SL 120J 50PT(#01)
		4030000650	Ceramic GRM40 SL 150J 50PT(#02)
4030000640		Ceramic GRM40 SL 120J 50PT(#03)	
4030000640		Ceramic GRM40 SL 120J 50PT(#04)	
4030000620		Ceramic GRM40 SL 080D 50PT(#05)	
4030000640		Ceramic GRM40 SL 120J 50PT(#06)	
C404		4030001090	Ceramic GRM40 B 471K 50PT
C405		4610000530	Trimmer TZB04Z060BA006
C406		4030000600	Ceramic GRM40 SL 060D 50PT
C407		4030000590	Ceramic GRM40 SL 050C 50PT
C408	4030000590	Ceramic GRM40 SL 050C 50PT(#01)	
	4030000590	Ceramic GRM40 SL 050C 50PT(#02)	
	4030000590	Ceramic GRM40 SL 050C 50PT(#03)	
	4030000620	Ceramic GRM40 SL 080D 50PT(#04)	
	4030000590	Ceramic GRM40 SL 050C 50PT(#05)	
	4030000620	Ceramic GRM40 SL 080D 50PT(#06)	

[RF UNIT]

REF. NO.	ORDER NO.	DESCRIPTION
Q501	1580000050	FET 3SK121-Y
Q502	1580000050	FET 3SK121-Y
D501	1720000180	Varicap 1SV164-T2B
D502	1720000180	Varicap 1SV164-T2B
D503	1720000180	Varicap 1SV164-T2B
D504	1720000180	Varicap 1SV164-T2B
D505	1720000180	Varicap 1SV164-T2B
L501	6110001520	Coil LA-232(#01)
	6110001520	Coil LA-232(#02)
	6110001520	Coil LA-232(#03)
	6110001520	Coil LA-232(#04)
	6110002110	Coil LA-382(#05)
	6110001520	Coil LA-232(#06)
L502	6110001520	Coil LA-232(#01)
	6110001520	Coil LA-232(#02)
	6110001520	Coil LA-232(#03)
	6110001520	Coil LA-232(#04)
	6110002110	Coil LA-382(#05)
	6110001520	Coil LA-232(#06)
L503	6110001520	Coil LA-232(#01)
	6110001520	Coil LA-232(#02)
	6110001520	Coil LA-232(#03)
	6110001520	Coil LA-232(#04)
	6110002110	Coil LA-382(#05)
	6110001520	Coil LA-232(#06)
L505	6110001520	Coil LA-232(#01)
	6110001520	Coil LA-232(#02)
	6110001520	Coil LA-232(#03)
	6110001520	Coil LA-232(#04)
	6110002110	Coil LA-382(#05)
	6110001520	Coil LA-232(#06)
L506	6110001520	Coil LA-232(#01)
	6110001520	Coil LA-232(#02)
	6110001520	Coil LA-232(#03)
	6110001520	Coil LA-232(#04)
	6110002110	Coil LA-382(#05)
	6110001520	Coil LA-232(#06)
R501	7030000560	Resistor MCR10EZHZ 47k Q (473)
R502	7030000620	Resistor MCR10EZHZ 100k Q (104)
R503	7030000260	Resistor MCR10EZHZ 100 Q (101)
R504	7030000620	Resistor MCR10EZHZ 100k Q (104)
R505	7030000140	Resistor MCR10EZHZ 10 Q (100)
R506	7030000580	Resistor MCR10EZHZ 47k Q (473)
R507	7030000580	Resistor MCR10EZHZ 47k Q (473)(#01)
	7030000580	Resistor MCR10EZHZ 47k Q (473)(#02)
	7030000580	Resistor MCR10EZHZ 47k Q (473)(#03)
	7030000500	Resistor MCR10EZHZ 10k Q (103)(#04)
	7030000500	Resistor MCR10EZHZ 10k Q (103)(#05)
	7030000500	Resistor MCR10EZHZ 10k Q (103)(#06)

## [RF UNIT]

REF. NO.	ORDER NO.	DESCRIPTION	
R508	7030000340	Resistor	MCR10EZHZ 470 Ω (471)
R509	7030000820	Resistor	MCR10EZHZ 100k Ω (104)
R510	7030000820	Resistor	MCR10EZHZ 100k Ω (104)
R511	7030000820	Resistor	MCR10EZHZ 100k Ω (104)
R512	7030000820	Resistor	MCR10EZHZ 100k Ω (104)
R513	7030000820	Resistor	MCR10EZHZ 100k Ω (104)
C501	4810000520	Trimmer	TZB04N100BA008
C502	4040000480	Barrier Layer	RAU 04AK R75C(#01)
	4040000480	Barrier Layer	RAU 04AK R75C(#02)
	4040000480	Barrier Layer	RAU 04AK R75C(#03)
	4040000480	Barrier Layer	RAU 04AK R75C(#04)
	4010000010	Ceramic	DD104 SL 0R5C 50V(#05)
	4040000480	Barrier Layer	RAU 04AK R75C(#08)
C503	4030000550	Ceramic	GRM40 SL 010C 50PT
C504	4810000520	Trimmer	TZB04N100BA008
C505	4030000590	Ceramic	GRM40 SL 050C 50PT
C506	4030001100	Ceramic	GRM40 B 102K 50PT
C507	4030001100	Ceramic	GRM40 B 102K 50PT
C508	4030001100	Ceramic	GRM40 B 102K 50PT
C509	4810000520	Trimmer	TZB04N100BA008
C511	4030000540	Ceramic	GRM40 SL 0R5C 50PT(#01)
	4030000540	Ceramic	GRM40 SL 0R5C 50PT(#02)
	4030000540	Ceramic	GRM40 SL 0R5C 50PT(#03)
	4030000540	Ceramic	GRM40 SL 0R5C 50PT(#04)
	4030003170	Ceramic	GRM40 SL 0R75C 50PT(#05)
	4030000540	Ceramic	GRM40 SL 0R5C 50PT(#08)
C512	4810000520	Trimmer	TZB04N100BA008(#01)
	4810000520	Trimmer	TZB04N100BA008(#02)
	4810000520	Trimmer	TZB04N100BA008(#03)
	4810000530	Trimmer	TZB04Z080BA008(#04)
	4810000520	Trimmer	TZB04N100BA008(#05)
	4810000530	Trimmer	TZB04Z080BA008(#08)
C513	4040000470	Barrier Layer	RAU 04AK R35C(#01)
	4040000470	Barrier Layer	RAU 04AK R35C(#02)
	4040000470	Barrier Layer	RAU 04AK R35C(#03)
	4040000470	Barrier Layer	RAU 04AK R35C(#04)
	4030000540	Ceramic	GRM40 SL 0R5C 50PT(#05)
	4040000470	Barrier Layer	RAU 04AK R35C(#08)
C515	4810000520	Trimmer	TZB04N100BA008
C516	4030000590	Ceramic	GRM40 SL 050C 50PT
C517	4010000280	Ceramic	DD104 SL 470J 50V
C518	4010000500	Ceramic	DD104 B 102K 50V
C519	4010000080	Ceramic	DD104 SL 040C 50V
C525	4030000820	Ceramic	GRM40 SL 080D 50PT(#01)
	4030000820	Ceramic	GRM40 SL 080D 50PT(#02)
	4030000820	Ceramic	GRM40 SL 080D 50PT(#03)
	4030000820	Ceramic	GRM40 SL 080D 50PT(#04)
	4030000810	Ceramic	GRM40 SL 070D 50PT(#05)
	4030000820	Ceramic	GRM40 SL 080D 50PT(#08)
C526	4030000820	Ceramic	GRM40 SL 080D 50PT(#01)
	4030000820	Ceramic	GRM40 SL 080D 50PT(#02)
	4030000820	Ceramic	GRM40 SL 080D 50PT(#03)
	4030000820	Ceramic	GRM40 SL 080D 50PT(#04)
	4030000810	Ceramic	GRM40 SL 070D 50PT(#05)
	4030000820	Ceramic	GRM40 SL 080D 50PT(#08)
C527	4030000820	Ceramic	GRM40 SL 080D 50PT(#01)
	4030000820	Ceramic	GRM40 SL 080D 50PT(#02)
	4030000820	Ceramic	GRM40 SL 080D 50PT(#03)
	4030000820	Ceramic	GRM40 SL 080D 50PT(#04)
	4030000810	Ceramic	GRM40 SL 070D 50PT(#05)
	4030000820	Ceramic	GRM40 SL 080D 50PT(#08)
C528	4030000820	Ceramic	GRM40 SL 080D 50PT(#01)
	4030000820	Ceramic	GRM40 SL 080D 50PT(#02)
	4030000820	Ceramic	GRM40 SL 080D 50PT(#03)
	4030000820	Ceramic	GRM40 SL 080D 50PT(#04)
	4030000810	Ceramic	GRM40 SL 070D 50PT(#05)
	4030000820	Ceramic	GRM40 SL 080D 50PT(#08)
C529	4030000820	Ceramic	GRM40 SL 080D 50PT(#01)
	4030000820	Ceramic	GRM40 SL 080D 50PT(#02)
	4030000820	Ceramic	GRM40 SL 080D 50PT(#03)
	4030000820	Ceramic	GRM40 SL 080D 50PT(#04)
	4030000810	Ceramic	GRM40 SL 070D 50PT(#05)
	4030000820	Ceramic	GRM40 SL 080D 50PT(#08)
C530	4030001100	Ceramic	GRM40 B 102K 50PT
C531	4030001100	Ceramic	GRM40 B 102K 50PT

## [RF UNIT]

REF. NO.	ORDER NO.	DESCRIPTION	
C532	4030001100	Ceramic	GRM40 B 102K 50PT(#01)
	4030001100	Ceramic	GRM40 B 102K 50PT(#02)
	4030001100	Ceramic	GRM40 B 102K 50PT(#03)
	4030001100	Ceramic	GRM40 B 102K 50PT(#04)
	4030001140	Ceramic	GRM40 F 103Z 50PT(#05)
	4030001100	Ceramic	GRM40 B 102K 50PT(#08)
C533	4030001100	Ceramic	GRM40 B 102K 50PT
C534	4030001100	Ceramic	GRM40 B 102K 50PT(#01)
	4030001100	Ceramic	GRM40 B 102K 50PT(#02)
	4030001100	Ceramic	GRM40 B 102K 50PT(#03)
	4030001100	Ceramic	GRM40 B 102K 50PT(#04)
	4030001140	Ceramic	GRM40 F 103Z 50PT(#05)
	4030001100	Ceramic	GRM40 B 102K 50PT(#08)
C535	4030001100	Ceramic	GRM40 B 102K 50PT
C536	4030001100	Ceramic	GRM40 B 102K 50PT
C537	4030001100	Ceramic	GRM40 B 102K 50PT
C538	4030001100	Ceramic	GRM40 B 102K 50PT
C539	4030001100	Ceramic	GRM40 B 102K 50PT(#01)
	4030001100	Ceramic	GRM40 B 102K 50PT(#02)
	4030001100	Ceramic	GRM40 B 102K 50PT(#03)
	4030001100	Ceramic	GRM40 B 102K 50PT(#04)
	4030001140	Ceramic	GRM40 F 103Z 50PT(#05)
	4030001100	Ceramic	GRM40 B 102K 50PT(#08)
C540	4030001100	Ceramic	GRM40 B 102K 50PT
C541	4030003170	Ceramic	GRM40 SL 0R75C 50PT(#05)
C542	4030003170	Ceramic	GRM40 SL 0R75C 50PT(#05)
EP501	0910012049	P.C.Board	B 10571 4(#01) (RF)
	0910012049	P.C.Board	B 10571 4(#02)
	0910012049	P.C.Board	B 10571 4(#03)
	0910012049	P.C.Board	B 10571 4(#04)
	0910018631	P.C.Board	B 1751A 4(#05)
	0910012049	P.C.Board	B 10571 4(#08)

## [DISPLAY UNIT]

REF. NO.	ORDER NO.	DESCRIPTION	
IC801	1130000790	IC	μ PD7225G
IC802	1120000800	IC	LR-40872
IC803	1130001250	IC	μ PD4068BG-T1
D801	1750000040	Diode	1SS190(TE85R)
D802	1750000040	Diode	1SS190(TE85R)
D803	1750000040	Diode	1SS190(TE85R)
D804	1750000040	Diode	1SS190(TE85R)
D805	1750000040	Diode	1SS190(TE85R)
D806	1750000040	Diode	1SS190(TE85R)
D807	1750000040	Diode	1SS190(TE85R)
X801	8080000150	Ceramic clock	CSAC3.58MGC300CD
R804	7030000850	Resistor	MCR10EZHZ 180k Ω (184)
R805	7030000520	Resistor	MCR10EZHZ 15k Ω (153)
R806	7030000520	Resistor	MCR10EZHZ 15k Ω (153)
R807	7030000540	Resistor	MCR10EZHZ 22k Ω (223)
R808	7030000580	Resistor	MCR10EZHZ 47k Ω (473)
C801	4030001100	Ceramic	GRM40 B 102K 50PT
C802	4030003080	Ceramic	GRM40 SL 300J 50PT
C803	4030003080	Ceramic	GRM40 SL 300J 50PT
C804	4030001100	Ceramic	GRM40 B 102K 50PT
C805	4030001100	Ceramic	GRM40 B 102K 50PT
C806	4030001100	Ceramic	GRM40 B 102K 50PT
C807	4010000480	Ceramic	DD104 B 471K 50V
C808	4030000700	Ceramic	GRM40 SL 470J 50PT
C809	4030000700	Ceramic	GRM40 SL 470J 50PT
C810	4030000700	Ceramic	GRM40 SL 470J 50PT
C811	4030000700	Ceramic	GRM40 SL 470J 50PT
C812	4030000700	Ceramic	GRM40 SL 470J 50PT
C813	4030000700	Ceramic	GRM40 SL 470J 50PT
C814	4030000700	Ceramic	GRM40 SL 470J 50PT
C815	4030000700	Ceramic	GRM40 SL 470J 50PT

[DISPLAY UNIT]

REF. NO.	ORDER NO.	DESCRIPTION	
DS801	5080000110	Lamp	BQ031-22403A
DS802	5030000150	LED	LP217A-E
MC801	7700000460	Microphone	KUC2023-01-008
SP801	2510000140	Speaker	40P-157B
EP803	0910012058	P.C.Board	B 1049F (DISPLAY)
EP804	0910012061	P.C.Board	B 1048A

[LOGIC UNIT]

REF. NO.	ORDER NO.	DESCRIPTION	
IC701	1130000580	IC	$\mu$ PD446C
IC702	1130001250	IC	$\mu$ PD4068BG-T1
IC703	1140000540	IC	$\mu$ PD78C08AG-570-12
IC704	1130001880	IC	$\mu$ PD4069UBG-T1
IC705	1130001250	IC	$\mu$ PD4068BG-T1
IC706	1130001830	IC	MN6520
Q701	1530000180	Transistor	2SC2712-Y (TE85RTEM)
Q702	1530000180	Transistor	2SC2712-Y (TE85RTEM)
Q703	1510000110	Transistor	2SA1182-Y (TE85R)
Q704	1510000110	Transistor	2SA1182-Y (TE85R)
D703	1750000010	Diode	1SS181(TE85R)
D704	1750000010	Diode	1SS181(TE85R)
D706	1730000410	Zener	RD5.1M-T2B2
D707	1750000020	Diode	1SS184(TE85R)
D708	1750000010	Diode	1SS181(TE85R)
D711	1750000020	Diode	1SS184(TE85R)
X701	8050001930	Crystal	CR-83
R701	7030000580	Resistor	MCR10EZHZ 47k $\Omega$ (473)
R702	7030000580	Resistor	MCR10EZHZ 47k $\Omega$ (473)
R703	7030000580	Resistor	MCR10EZHZ 47k $\Omega$ (473)
R704	7030000580	Resistor	MCR10EZHZ 47k $\Omega$ (473)
R705	7030000580	Resistor	MCR10EZHZ 47k $\Omega$ (473)
R706	7030000580	Resistor	MCR10EZHZ 47k $\Omega$ (473)
R707	7030000580	Resistor	MCR10EZHZ 47k $\Omega$ (473)
R708	7030000520	Resistor	MCR10EZHZ 15k $\Omega$ (153)
R709	7030000730	Resistor	MCR10EZHZ 820k $\Omega$ (824)(#01)
	7030000730	Resistor	MCR10EZHZ 820k $\Omega$ (824)(#02)
	7030000730	Resistor	MCR10EZHZ 820k $\Omega$ (824)(#03)
	7030000730	Resistor	MCR10EZHZ 820k $\Omega$ (824)(#04)
	7030000730	Resistor	MCR10EZHZ 820k $\Omega$ (824)(#05)
	7030000730	Resistor	MCR10EZHZ 820k $\Omega$ (824)(#06)
R711	7030000500	Resistor	MCR10EZHZ 10k $\Omega$ (103)
R712	7030000500	Resistor	MCR10EZHZ 10k $\Omega$ (103)
R713	7030000500	Resistor	MCR10EZHZ 10k $\Omega$ (103)
R714	7030000520	Resistor	MCR10EZHZ 15k $\Omega$ (153)
R715	7030000500	Resistor	MCR10EZHZ 10k $\Omega$ (103)
R716	7030000460	Resistor	MCR10EZHZ 4.7k $\Omega$ (472)
R717	7030000700	Resistor	MCR10EZHZ 470k $\Omega$ (474)
R718	7030000480	Resistor	MCR10EZHZ 6.8k $\Omega$ (682)
R719	7030000370	Resistor	MCR10EZHZ 820 $\Omega$ (821)(#01)
	7030000410	Resistor	MCR10EZHZ 1.8k $\Omega$ (182)(#02)
	7030000370	Resistor	MCR10EZHZ 820 $\Omega$ (821)(#03)
	7030000370	Resistor	MCR10EZHZ 820 $\Omega$ (821)(#04)
	7030000370	Resistor	MCR10EZHZ 820 $\Omega$ (821)(#05)
	7030000370	Resistor	MCR10EZHZ 820 $\Omega$ (821)(#06)
R720	7030000540	Resistor	MCR10EZHZ 22k $\Omega$ (223)
R721	7030000550	Resistor	MCR10EZHZ 27k $\Omega$ (273)
R722	7030000570	Resistor	MCR10EZHZ 39k $\Omega$ (393)
R724	7030000740	Resistor	MCR10EZHZ 1M $\Omega$ (105)
R726	7030000820	Resistor	MCR10EZHZ 100k $\Omega$ (104)
R727	7030000740	Resistor	MCR10EZHZ 1M $\Omega$ (105)
R728	7030000860	Resistor	MCR10EZHZ 220k $\Omega$ (224)
R729	7030000700	Resistor	MCR10EZHZ 470k $\Omega$ (474)
R730	7030000580	Resistor	MCR10EZHZ 47k $\Omega$ (473)
R731	7030000380	Resistor	MCR10EZHZ 1k $\Omega$ (102)
R732	7030000580	Resistor	MCR10EZHZ 47k $\Omega$ (473)

[LOGIC UNIT]

REF. NO.	ORDER NO.	DESCRIPTION	
R733	7030000380	Resistor	MCR10EZHZ 1k $\Omega$ (102)
C701	4030001150	Ceramic	GRM40 F 104Z 25PT
C705	4510001520	Electrolytic	6.3 RC3 47 $\mu$ F
C706	4030001150	Ceramic	GRM40 F 104Z 25PT
C707	4510001620	Electrolytic	50 RC3 1 $\mu$ F
C708	4030001150	Ceramic	GRM40 F 104Z 25PT
C709	4510002280	Electrolytic	16 RC3 22 $\mu$ F
C711	4510001580	Electrolytic	50 RC3 0.1 $\mu$ F
C712	4030001150	Ceramic	GRM40 F 104Z 25PT
C713	4030001140	Ceramic	GRM40 F 103Z 50PT
C714	4030001140	Ceramic	GRM40 F 103Z 50PT
C716	4030000700	Ceramic	GRM40 SL 470J 50PT
C717	4030001150	Ceramic	GRM40 F 104Z 25PT
C718	4030001100	Ceramic	GRM40 B 102K 50PT
C719	4030001140	Ceramic	GRM40 F 103Z 50PT
C720	4030001150	Ceramic	GRM40 F 104Z 25PT(#01)
	4030001150	Ceramic	GRM40 F 104Z 25PT(#02)
	4030001150	Ceramic	GRM40 F 104Z 25PT(#03)
	4030001150	Ceramic	GRM40 F 104Z 25PT(#04)
	4030001150	Ceramic	GRM40 F 104Z 25PT(#05)
	4030001150	Ceramic	GRM40 F 104Z 25PT(#06)
C721	4550000400	Tantalum	DN 1C 2R2M
J701	8910003140	Connector	IMSA-9202B-1-02T
P701	8910003120	Connector	IMSA-9206H-T
EP702	0910012078	P.C.Board	B 1048H (LOGIC)



# SECTION 8 BOARD LAYOUTS

## MAIN UNIT





PLL UNIT #01 #02 #03

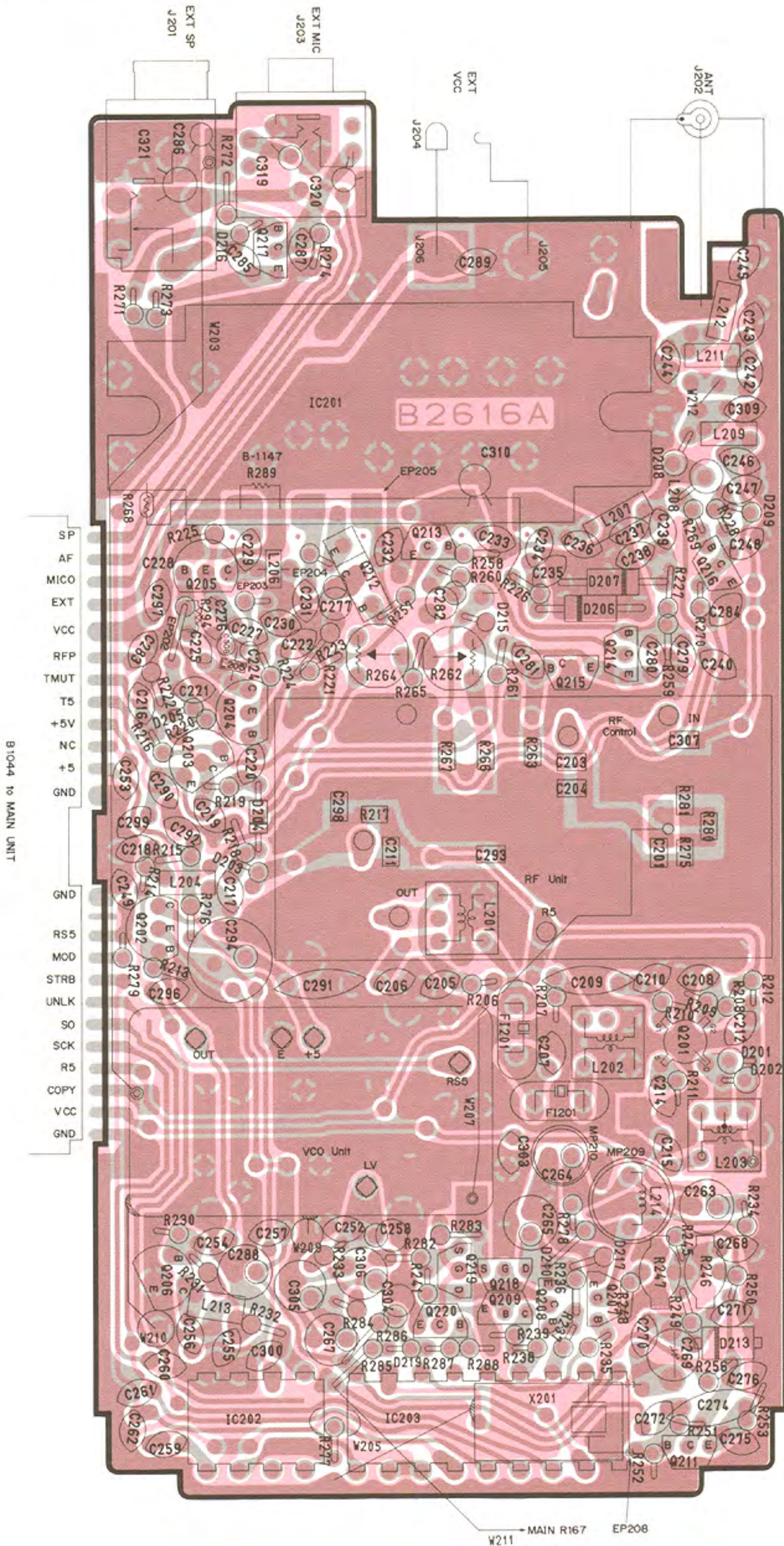



PLL UNIT #04 #05 #06

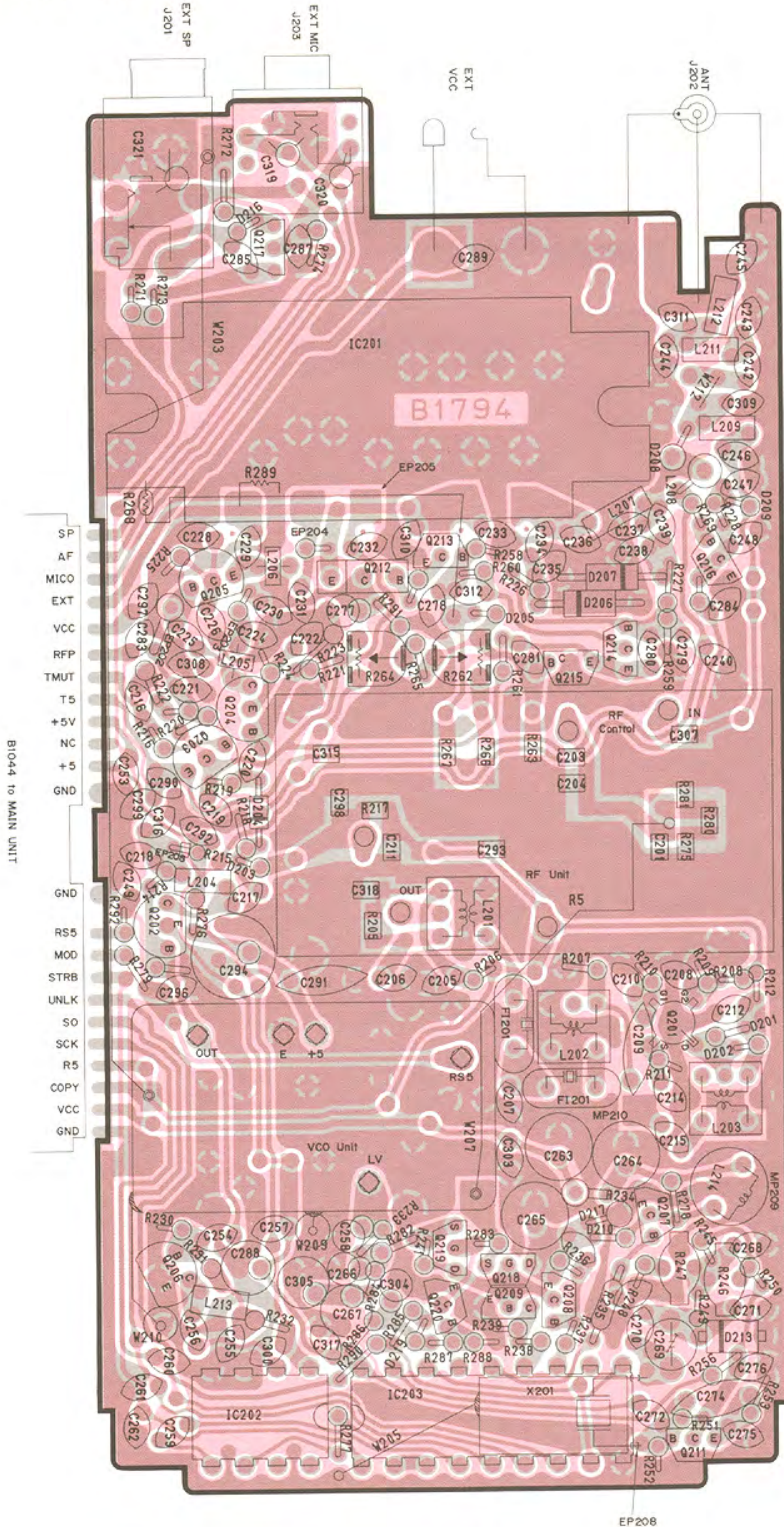







# DISPLAY UNIT

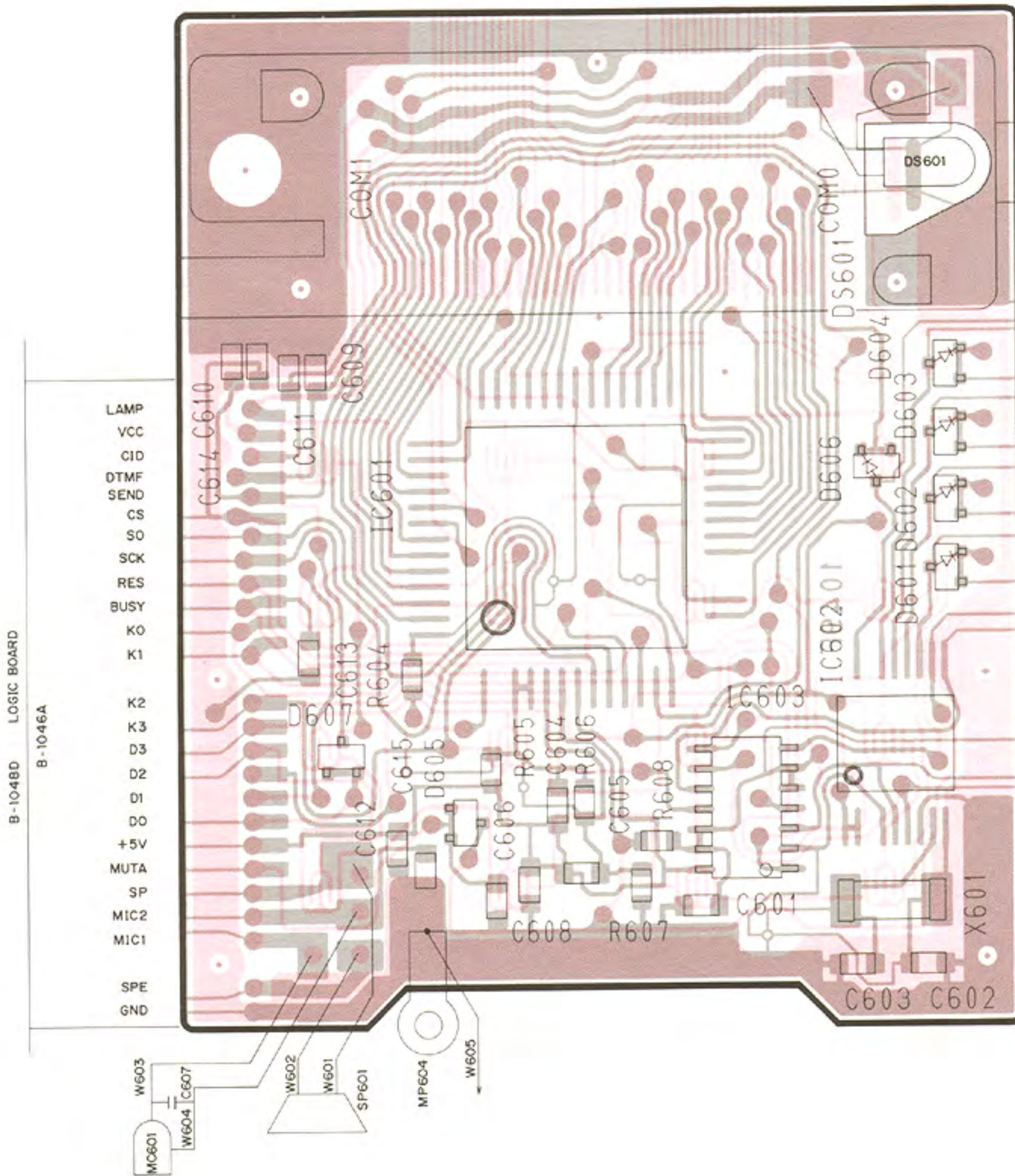



RF UNIT #01 #02 #03 #04 #06

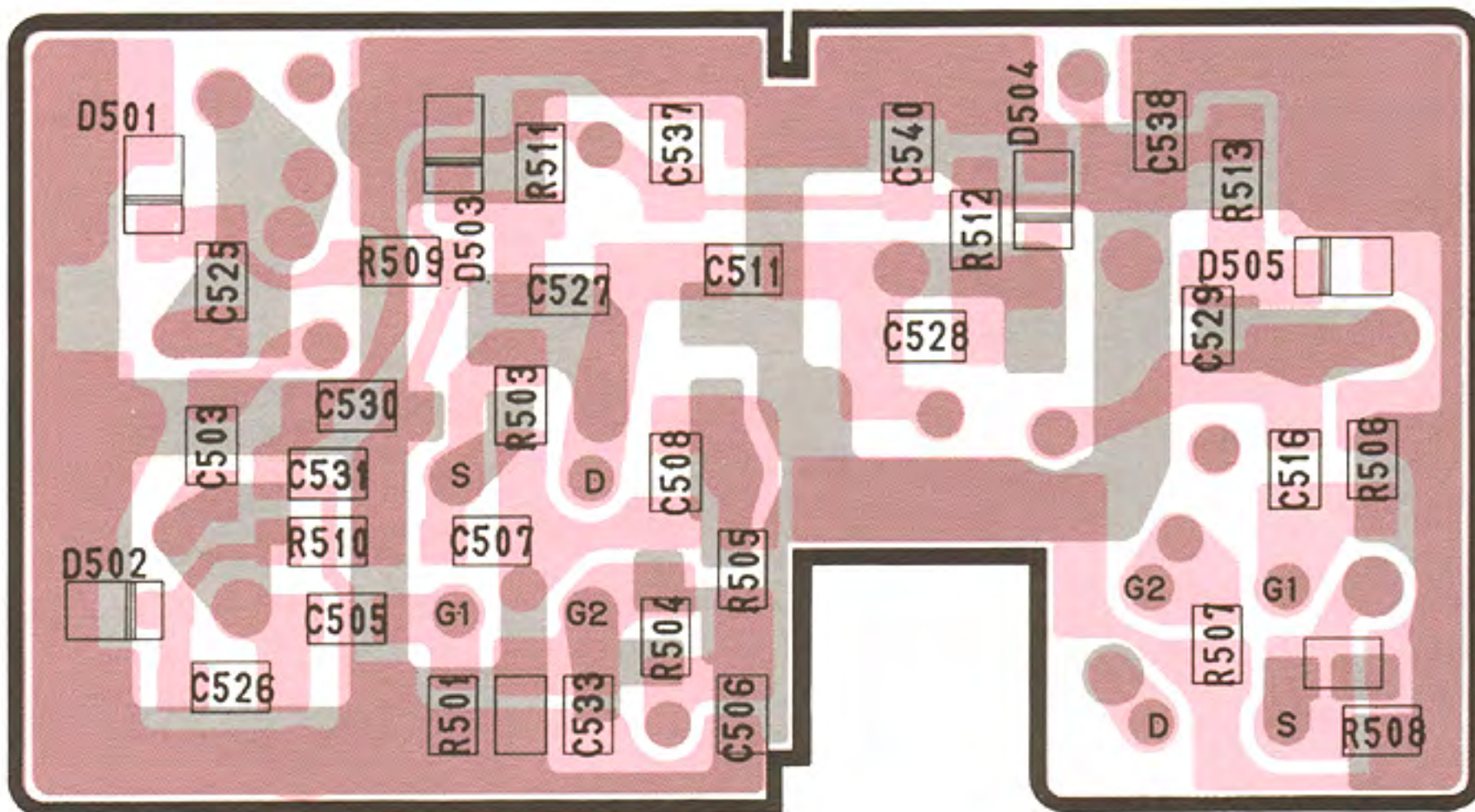
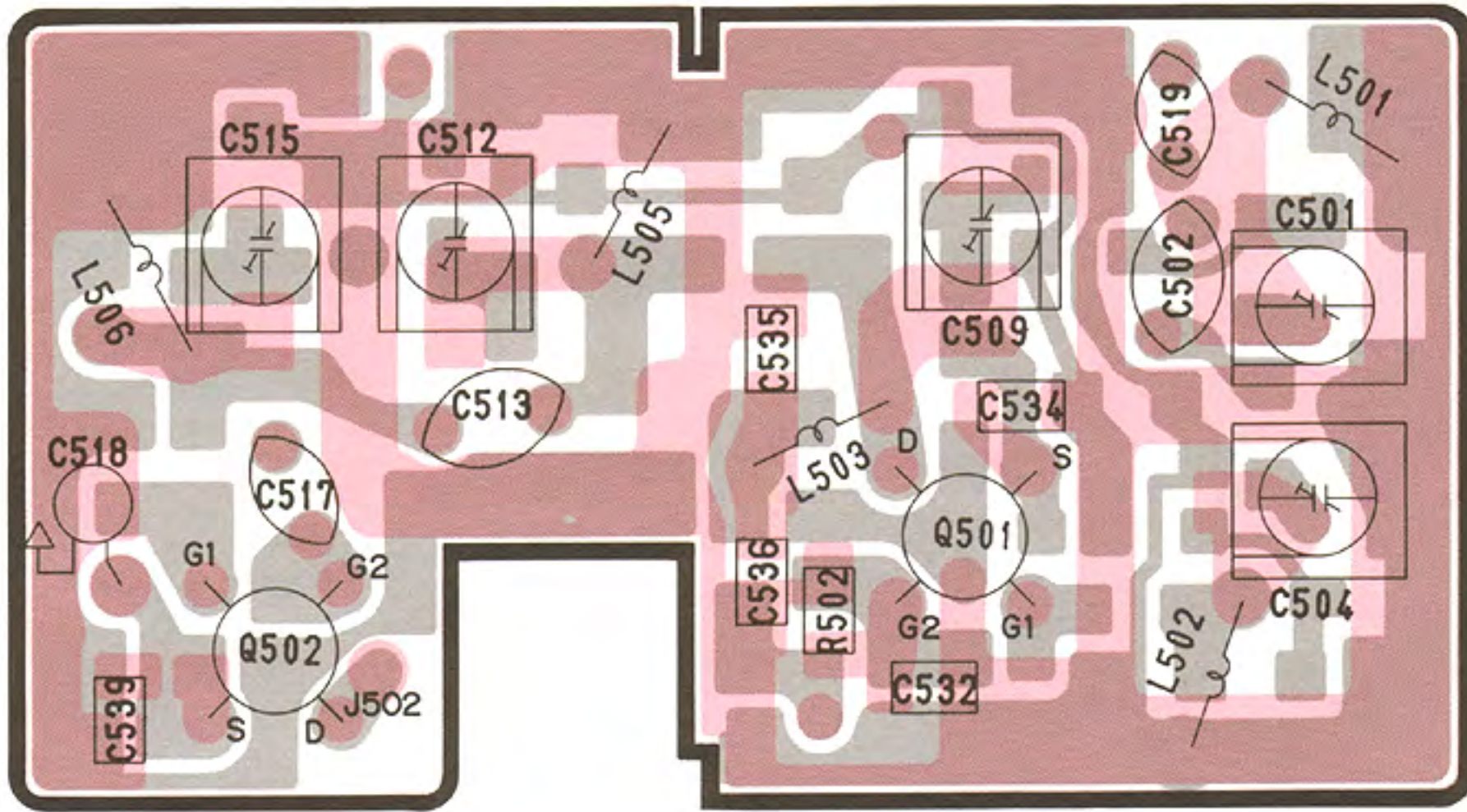



RF UNIT #05

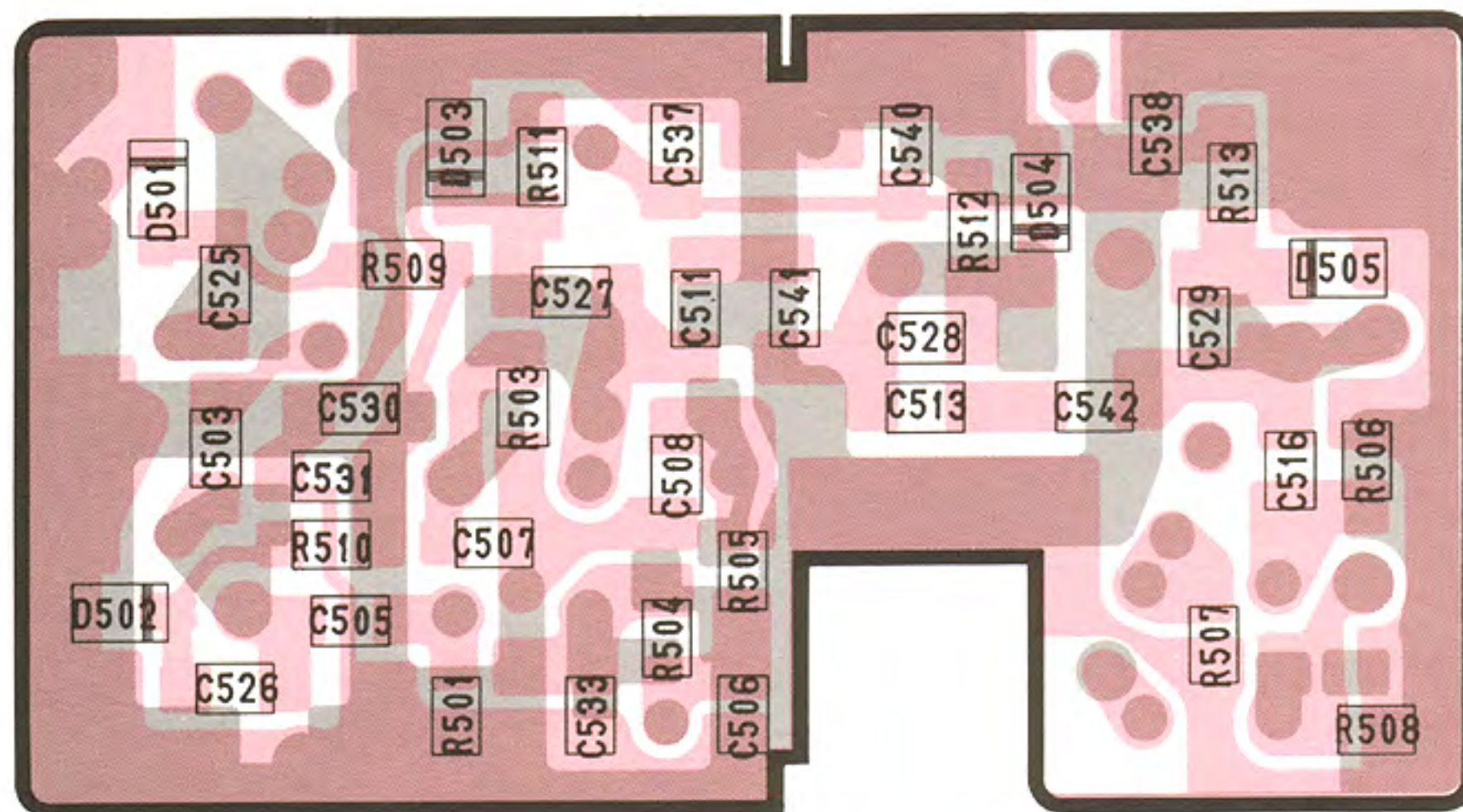
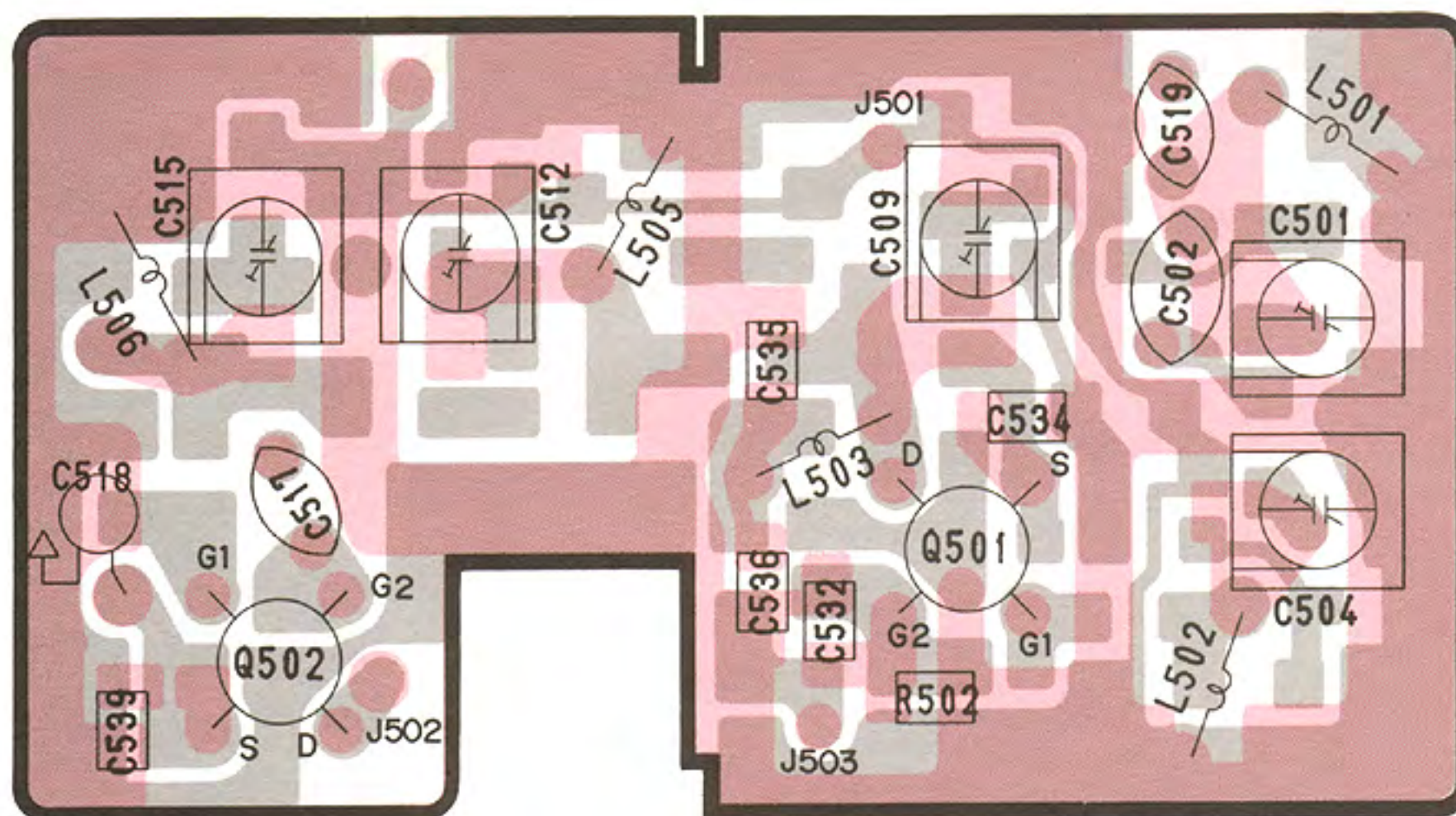

VCO UNIT

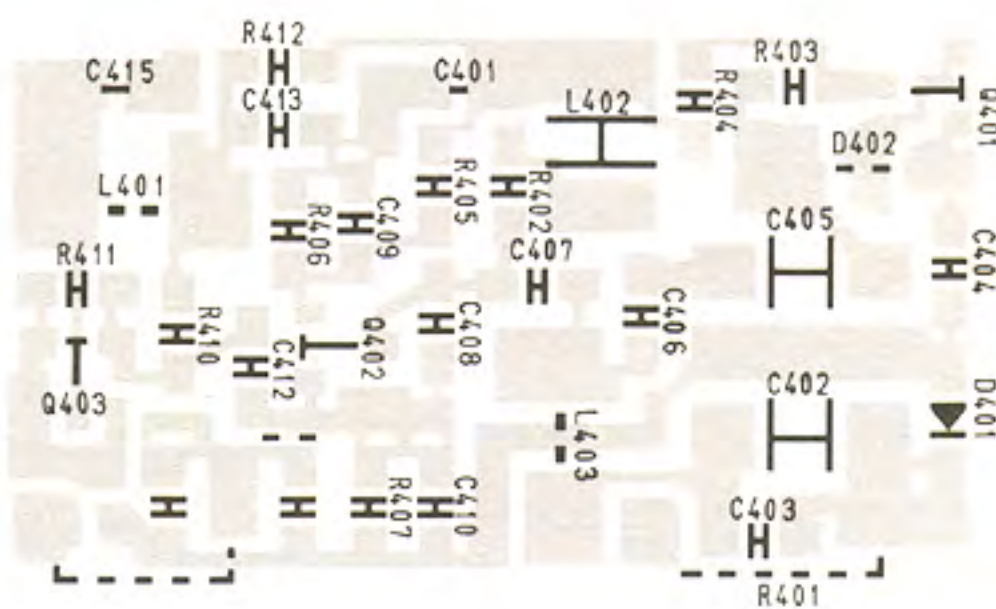



# SECTION 9 BATTERY PACK SCHEMATIC DIAGRAM

CM-7

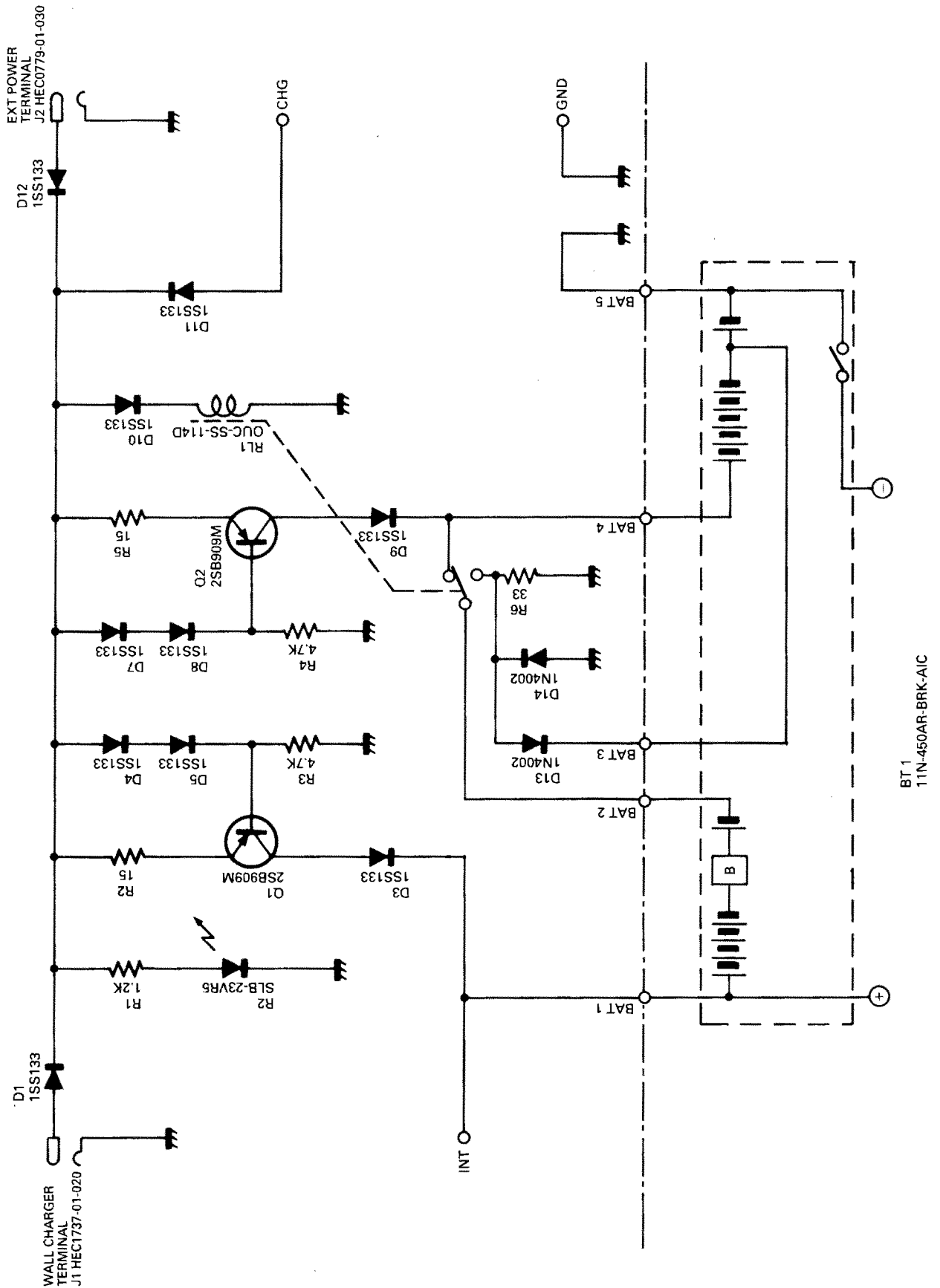

BT 1  
11N-450AR-BRK-A1C

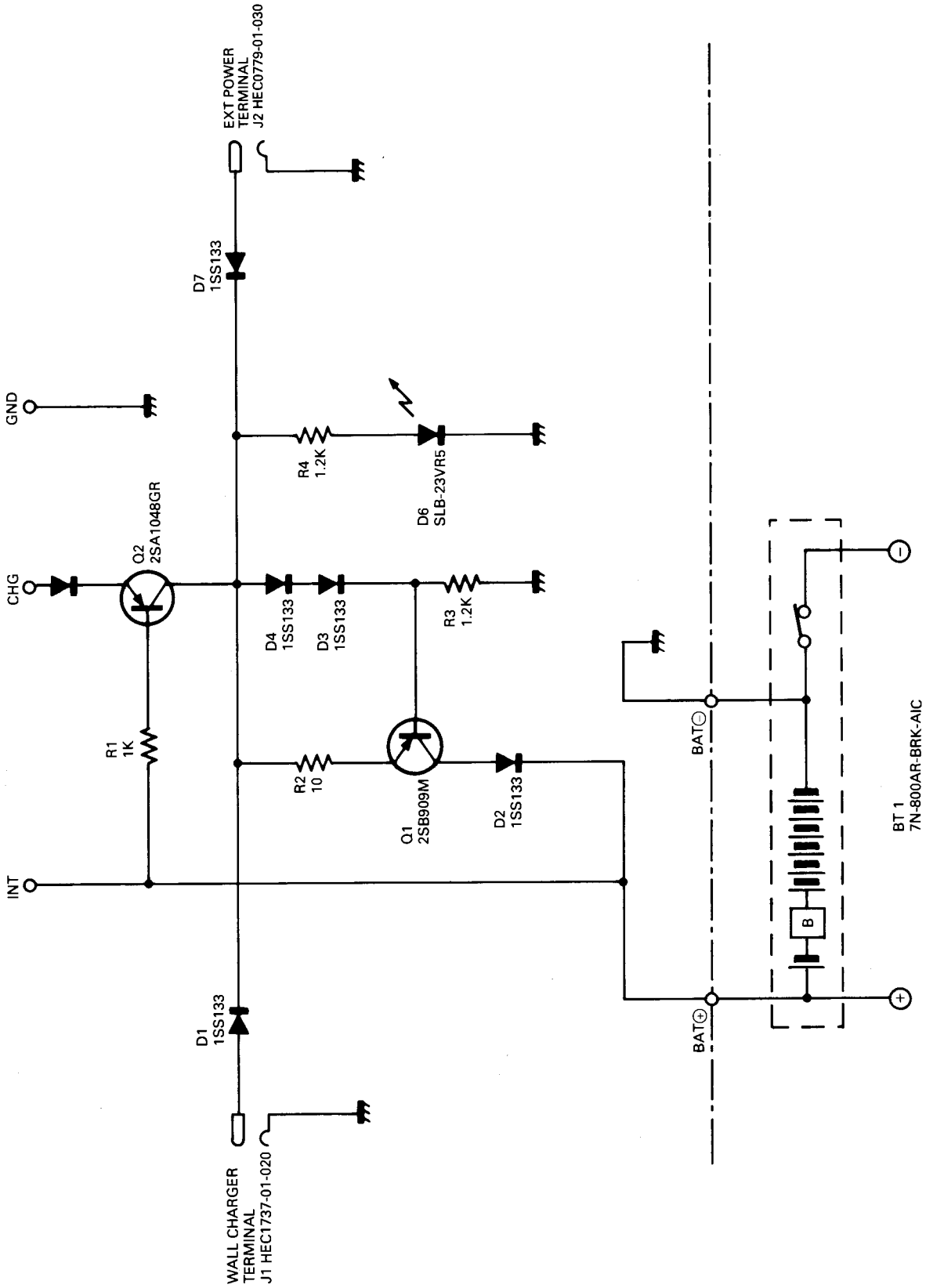

# SECTION 10 BLOCK DIAGRAM

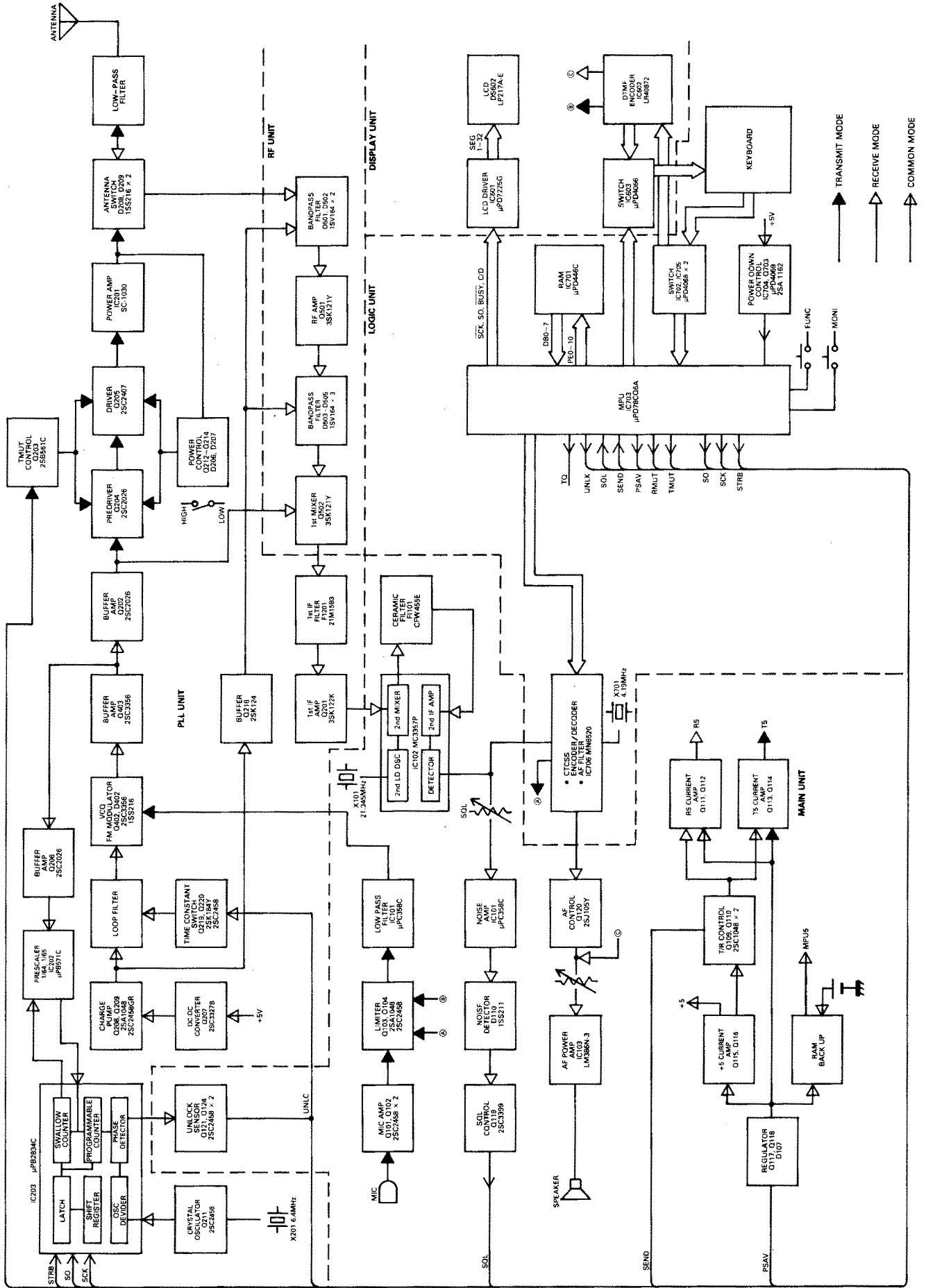



Refer to the schematic diagram and this table to know the specifications for each version.

FI101	CFW455E CFW455HT	#01,#03,#04,#05,#06 #02
R128	1.5 Ω 3.3 k Ω	#01,#03,#04,#05,#06 #02
R131	1.5 k Ω 2.2 k Ω	#01,#03,#04,#05,#06 #02
R132	1.5 k Ω 2.2 k Ω	#01,#03,#04,#05,#06 #02
R162	1.8 k Ω 5.6 k Ω	#01,#03,#04,#05,#06 #02
R167	22 k Ω 150 k Ω	#04,#05,#06 #01,#02,#03
R181	27 k Ω 68 k Ω	#01,#03,#04,#05,#06 #02

IC201	SC1030 SC1090 SC1099	#01,#02,#03 #04,#06 #05
L204	LA-232 LA-233	#01,#02,#03,#05 #04,#06
L207	LA-232 LA-242	#01,#03 #02,#04,#06
L209	LA-223 LA-232	#01,#03 #02,#04,#05,#06
L211	LA-382	#01,#03,#04,#06
R205	4.7 k Ω	#04,#05,#06
R207	4.7 k Ω 10 k Ω	#04,#05,#06 #01,#02,#03
R234	470 Ω 560 Ω	#01,#02,#03 #04,#05,#06
R235	10 k Ω 10 k Ω	#01,#02,#03 #04,#05,#06
R237	15 k Ω 47 k Ω	#02 #01,#03,#04,#06
R241	1.5 k Ω 2.7 k Ω	#02 #01,#03,#04,#06
R248	12 k Ω 15 k Ω	#04,#05,#06 #01,#02,#03
R264	2.2 k Ω 3.3 k Ω	#01,#02,#03 #04,#05,#06
R267	10 k Ω 18 k Ω	#01,#02,#03,#04,#06 #05
R289	82 Ω 220 Ω	#01,#03 #05
R290	100 k Ω	#04,#05,#06
R291	10 k Ω	#04,#05,#06
R292	3.3 k Ω	#04,#05,#06
R294	22 Ω	#02
C205	0.001 μ F 0.0001 μ F	#01,#02,#03 #04,#05,#06
C206	39 pF 47 pF	#04,#05,#06 #01,#02,#03
C207	7 pF 15 pF	#01,#03,#04,#05,#06 #02
C209	150 pF 180 pF	#04,#05,#06 #01,#02,#03
C210	56 pF 62 pF	#04,#05,#06 #01,#02,#03
C217	6 pF 8 pF	#05 #01,#02,#03,#04,#06
C227	0.001 μ F	#01,#02,#03
C242	18 pF 22 pF	#01,#02,#03,#05 #04,#06
C243	8 pF 12 pF	#01,#02,#03,#05 #04,#06
C244	10 pF 15 pF	#01,#02,#03,#05 #04,#06
C245	6 pF 10 pF	#01,#02,#03,#05 #04,#06
C247	22 pF 24 pF	#05 #01,#02,#03,#04,#06
C252	47 pF	#01,#02,#03

C266	0.1 pF 2.2 pF	#04,#06 #05
C278	47 pF	#04,#05,#06
C286	47 pF	#01,#02,#03
C287	470 pF 47 pF	#04,#06 #01,#02,#03,#05
C306	100 pF	#01,#02,#03
C312	47 pF	#04,#05,#06
C316	470 pF	#04,#05,#06
C317	0.01 μ F	#04,#05,#06
FI201	21M 7B2 21M15B3	#02 #01,#03,#04,#05,#06

C403	8 pF 12 pF 15 pF	#05 #01,#03,#04,#06 #02
C410	4 pF 6 pF	#05 #01,#02,#03,#04,#06
C412	10 pF 0.5 pF 0.75 pF	#01,#03 #02 #04,#05,#06
L403	LA-135 LA-384	#01,#02,#03,#04,#06 #05
R402	100 Ω 150 Ω	#02 #01,#03,#04,#05,#06
R412	100 Ω 220 Ω	#02 #01,#03,#04,#05,#06

L501	LA-232 LA-382	#01,#02,#03,#04,#06 #05
L502	LA-232 LA-382	#01,#02,#03,#04,#06 #05
L503	LA-232 LA-382	#01,#02,#03,#04,#06 #05
L505	LA-232 LA-382	#01,#02,#03,#04,#06 #05
L506	LA-232 LA-382	#01,#02,#03,#04,#06 #05
R507	10 k Ω 47 k Ω	#04,#05,#06 #01,#02,#03
C502	0.5 pF 0.75 pF	#05 #01,#02,#03,#04,#06
C511	0.5 pF 0.75 pF	#01,#02,#03,#04,#06 #05
C512	10 pF 6 pF	#01,#02,#03,#05 #04,#06
C513	0.5 pF	#05
C525	7 pF 8 pF	#05 #01,#02,#03,#04,#06
C526	7 pF 8 pF	#05 #01,#02,#03,#04,#06
C527	7 pF 8 pF	#05 #01,#02,#03,#04,#06
C528	7 pF 8 pF	#05 #01,#02,#03,#04,#06
C529	7 pF 8 pF	#05 #01,#02,#03,#04,#06
C532	0.001 μ F 0.01 μ F	#01,#02,#03,#04,#06 #05
C534	0.001 μ F 0.01 μ F	#01,#02,#03,#04,#06 #05
C539	0.001 μ F 0.01 μ F	#01,#02,#03,#04,#06 #05
C541	0.75 pF	#05
C542	0.75 pF	#05

R719	1.8 k Ω (182) 820 Ω (821)	#02 #01,#03,#04,#05,#06
------	------------------------------	----------------------------

# IC-U16 SCHEMATIC DIAGRAM

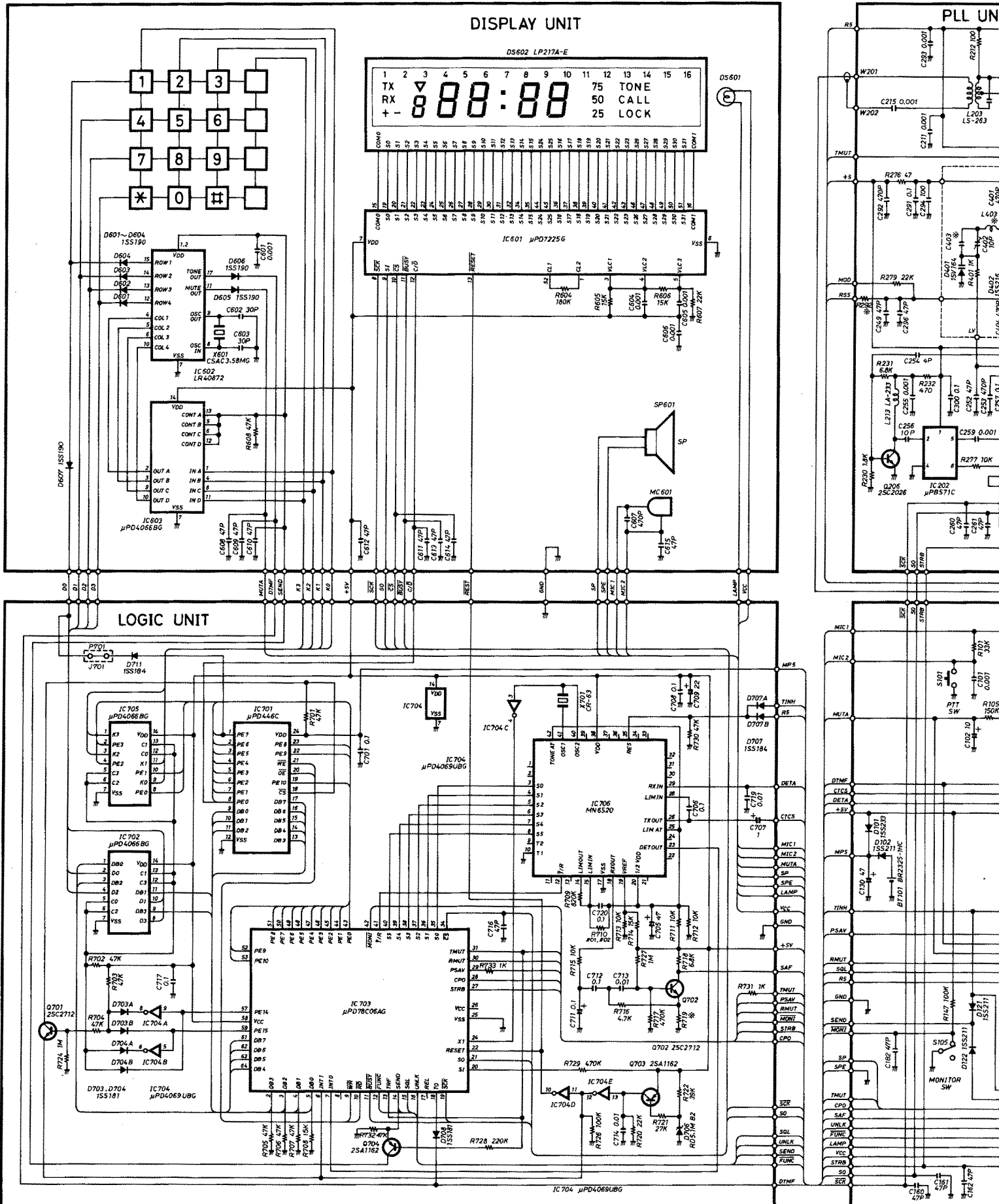



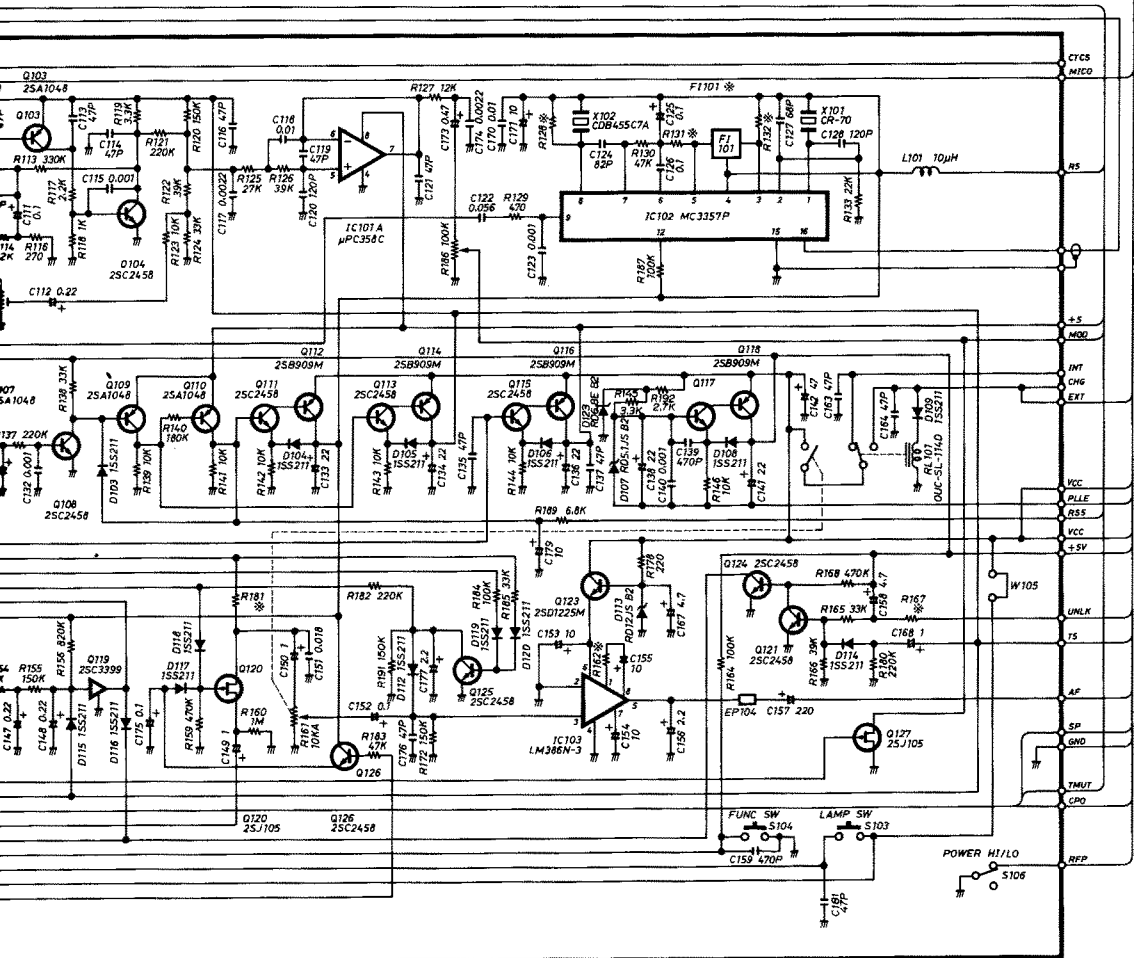
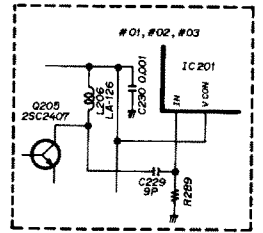
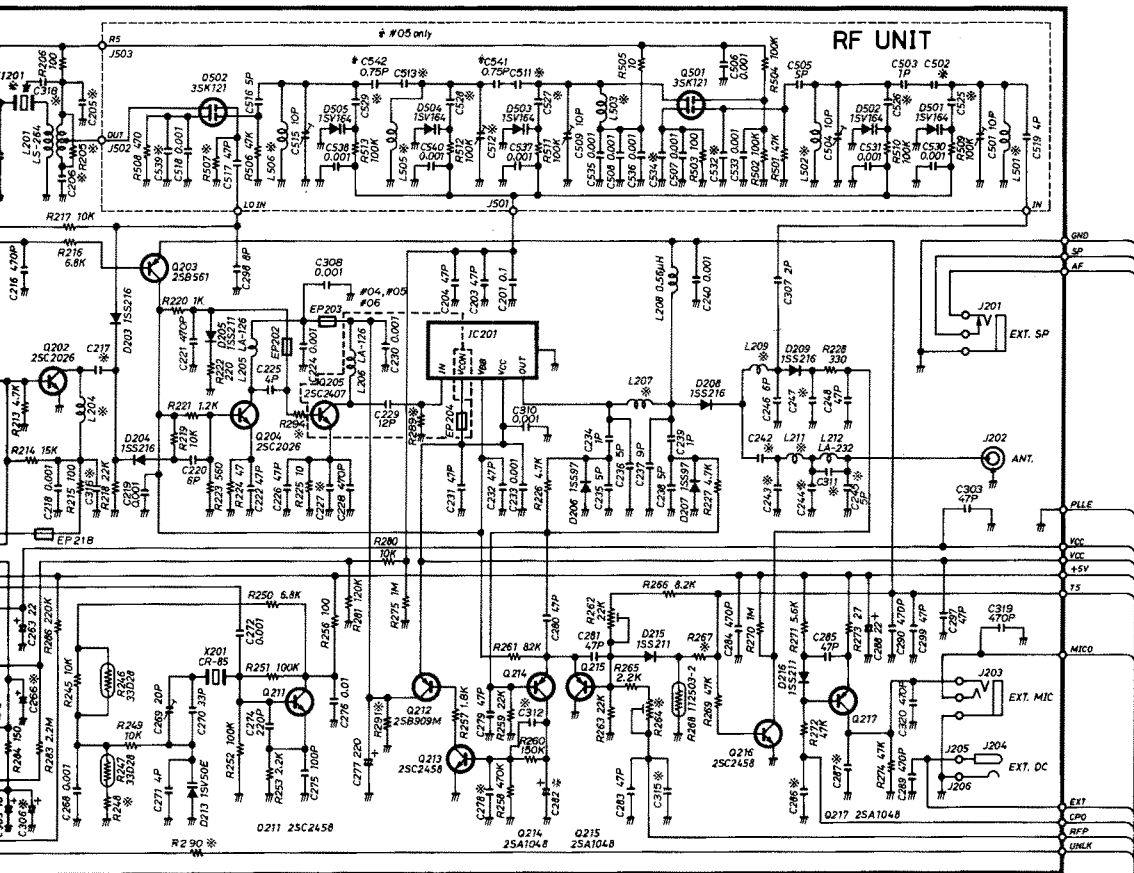

## Icom Inc.

6-9-16, Kamihigashi, Hirano-ku, Osaka 547, Japan

Phone : 06 793 5301

Fax : 06 793 0013

Telex : 05277822 ICOMTR J

### Icom America Inc.

<Corporate Headquarters>  
2380 116th Avenue N.E., Bellevue, WA 98004, U.S.A.  
Phone : (206) 454-8155  
Fax : (206) 454-1509  
Telex : 152210 ICOM AMER BVUE

<Customer Service>  
Phone : (206) 454-7619

<Regional Customer Service Centers>  
3150 Premier Drive, Suite 126, Irving, TX 75063, U.S.A.  
Phone : (214) 550-7525  
Fax : (214) 550-7423

1777 Phoenix Parkway, Suite 201, Atlanta, GA 30349, U.S.A.  
Phone : (404) 991-6166  
Fax : (404) 991-6327

### Icom Canada

A Division of Icom America Inc.  
3071 #5 Road, Unit 9, Richmond, B.C., V6X 2T4, Canada  
Phone : (604) 273-7400  
Fax : (604) 273-1900

### Icom (Europe) GmbH

Communication Equipment  
Himmelgeister Str. 100, 4000 Düsseldorf 1, W. Germany  
Phone : 0211 346047  
Fax : 0211 333639  
Telex : 8588082 ICOM D

### Icom (Australia) Pty. Ltd.

Incorporated In Victoria  
7 Duke Street, Windsor, Victoria, 3181, Australia  
Phone : 03 529 7582  
Fax : 03 529 8485  
Telex : AA 35521 ICOM AS

### Icom (UK) Ltd.

Unit 9, Sea St., Herne Bay, Kent, CT6 8LD, U.K.  
Phone : 0227 363859  
Fax : 0227 360155  
Telex : 965179 ICOM G

### Icom France S.a

120 Route de Revel, BP4063, 31029 Toulouse Cedex, France  
Phone : 61. 20. 31. 49  
Fax : 61. 34. 05. 91  
Telex : 521515 ICOM FRA

Count on us!